



SM24TBT4XPA

Managed 2.5G PoE++ Switch with IEEE 1588v2

(12) 10/100/1000Base-T ports, (12) 100/1G/2.5GBase-T ports, and
(4) 1G/10G SFP+ ports

Install Guide

Part Number 33876
Revision B August 2024

Intellectual Property

© 2024 Lantronix, Inc. All rights reserved. No part of the contents of this publication may be transmitted or reproduced in any form or by any means without the written permission of Lantronix.

Lantronix is a registered trademark of Lantronix, Inc. in the United States and other countries. All other trademarks and trade names are the property of their respective holders.

Patented: <https://www.lantronix.com/legal/patents/>; additional patents pending.

Warranty

For details on the Lantronix warranty policy, go to <http://www.lantronix.com/support/warranty>.

Contacts

Lantronix Corporate Headquarters

48 Discovery, Suite 250
Irvine, CA 92618, USA
Toll Free: 800-526-8766
Phone: 949-453-3990
Fax: 949-453-3995

Technical Support

Online: <https://www.lantronix.com/technical-support/>

Sales Offices

For a current list of our domestic and international sales offices, go to www.lantronix.com/about/contact.

Disclaimer

All information contained herein is provided "AS IS." Lantronix undertakes no obligation to update the information in this publication. Lantronix does not make, and specifically disclaims, all warranties of any kind (express, implied or otherwise) regarding title, non-infringement, fitness, quality, accuracy, completeness, usefulness, suitability or performance of the information provided herein. Lantronix shall have no liability whatsoever to any user for any damages, losses and causes of action (whether in contract or in tort or otherwise) in connection with the user's access or usage of any of the information or content contained herein. The information and specifications contained in this document are subject to change without notice.

Revision History

Date	Rev	Description
5/24/24	A	Initial Lantronix release at FW 8.50.0139.
8/15/24	B	FW v8.50.0149: Percepixon related adjustments and bugs fixes. <ul style="list-style-type: none"> ◆ Update Regulatory Compliance information. ◆ Correct the default fallback IP address. ◆ Disable SNMP mode by default. ◆ Fix PoE Firmware version display and fix PoE power output issue. ◆ Note that 10 Mbps and 10 Gbps are not supported. ◆ Remove 'Extend PoE Mode' feature. See the Release Notes for details.

Cautions and Warnings

Cautions indicate that there is the possibility of poor equipment performance or potential damage to the equipment.

Warnings indicate that there is the possibility of injury to person.

Cautions and Warnings appear here and may appear throughout this manual where appropriate. Failure to read and understand the information identified by this symbol could result in poor equipment performance, damage to the equipment, or injury to persons.



Caution: While installing or servicing the power supply module, wear a grounding device and observe all electrostatic discharge precautions. Failure to observe this caution could result in damage to, or failure of the power module.



Warning: Do not connect the power module to an external power source before installing it into the chassis. Failure to observe this warning could result in an electrical shock, even death.

Warning: Equipment grounding is vital to ensure safe operation. The installer must ensure that the power module is properly grounded during and after installation. Failure to observe this warning could result in an electric shock, even death.

Warning: A readily accessible, suitable National Electrical Code (NEC) or local electrical code approved disconnect device and branch-circuit protector must be part of the building's installed wiring to accommodate permanently connected equipment. Failure to observe this warning could result in an electric shock, even death.

Warning: Turn any external power source OFF and ensure that the power module is disconnected from the external power source before performing any maintenance. Failure to observe this warning could result in an electrical shock, even death.

Warning: Ensure that the disconnect device for the external power source is OPEN (*turned OFF*) before disconnecting or connecting the power leads to the power module. Failure to observe this warning could result in an electric shock, even death.

See [Electrical Safety Warnings](#) on page 32 for electrical safety warnings translated into multiple languages.

Contents

1. Introduction	5
Key Features	5
Ordering Information.....	6
Specifications.....	6
Software Features	7
About This Manual.....	10
Related Manuals.....	10
2. Product Description	11
Overview.....	11
Front Panel	11
Back Panel.....	11
LED Descriptions	12
MODE/RESET Button.....	14
3. Installation	15
Package Contents	15
Mounting the Switch in a 19-inch Rack	16
Mounting the Switch on Desk or Shelf.....	16
Connecting PoE Devices	17
Installing SFP+ Modules.....	18
Connecting the AC Power Cord	19
4. Initial Switch Setup	20
Initial Switch Setup via Web Browser	20
Initial Switch Configuration via Web Browser.....	20
Initial Switch Setup via CLI	21
5. Troubleshooting, Support, and Compliance	22
Troubleshooting	22
PoE Modes and Compliance	23
Troubleshooting PoE Problems.....	24
Labels	25
Recording Device and System Information	26
Compliance Information.....	27
FCC Regulations	27
Canadian Regulations	27
Declaration of Conformity	28
UKCA Certificate of Conformity	29
CE Certificate of Conformity	30
FCC Certificate of Conformity.....	31
NDAA, RoHS, REACH and WEEE Compliance.....	32
Electrical Safety Warnings.....	32

1. Introduction

The Lantronix SM24TBT4XPA Managed PoE++ Switch features IEEE 1588v2 Precision Clock Synchronization Protocol, (12) 10/100/1000Base-T ports, (12) 100/1G/2.5GBase-T ports, and (4) 1G/10G SFP+ ports to deliver better functionality and performance for enterprise networks. This switch also comes integrated with the Lantronix cloud-based or on-premise [PercepXion™](#) Software End-to-End Solutions platform, providing comprehensive device life cycle management, enterprise application integration, and data analytics, all through a single pane of glass.

With advanced Layer 2 features and a simple to navigate user interface, this switch offers performance and reliability at a cost-effective, secure, and reliable solution for the network edge.

Utilizing PoE enables users to connect, power and manage devices using a single Ethernet cable; simplifying installation and eliminating the need for additional power outlets.

This switch provides the benefits of ease of use in Security and Surveillance, Smart Building, and other applications. The switch also includes Device Management System Software (DMS), is accessible by PercepXion, or the local web manager, providing advanced configuration and management of all IP addressable devices in the network. This advanced management provides a graphical network topology, floor map creator, device map view, traffic monitoring, and network diagnostics for troubleshooting.

Key Features

- IPv4/IPv6 dual stack management
- IEEE 802.3af/at/bt
- Always on PoE
- Advanced PoE Management
- 2.5G RJ-45 Ports
- SSH/SSL secured management
- SNMP v1/v2c
- RMON groups 1,2,3,9
- IGMP v1/v2 Snooping and MLD v1/v2 Snooping
- RADIUS and TACACS+ authentication
- IP Source Guard
- DHCP Relay (Option 82) and DHCP Snooping
- 802.1d (STP), 802.1w (RSTP) and 802.1s (MSTP)
- LACP and static link aggregation
- DMS (Device Management System)
- PercepXion and LPM support
- 5 Year Warranty

Ordering Information

Model	Description
SM24TBT4XPA	Managed 2.5G PoE++ Switch with IEEE 1588v2 and (12) 10/100/1000Base-T ports, (12) 100/1G/2.5GBase-T ports, and (4) 1G/10G SFP+ ports
Optional Accessories (order separately)	
SFP Modules	See Lantronix full line of SFP transceivers on our SFP webpage .
PercepXion	Centralized cloud-based or on-premise Management Software. For PercepXion cloud-based software-as-a-service, select an annual subscription model.
CF-NWSCLOUDSAAS-xYR	PercepXion Cloud Subscription x-Years (1,3 or 5 years)
LEVEL-x-yYEAR	Technical Support Services, Level 1, 2 or 3 and 1, 3 or 5 year subscription

Specifications

Hardware Performance

Transmission Method	Forwarding Capacity (Mbps)	Switching Capacity (Gbps)	Mac Table (K)	Jumbo Frames (Bytes)
Store-and-forward	122	164	32	14000

Environmental Range

Operating Temperature		Storage Temperature		Operating Humidity	Altitude	
Fahrenheit	Centigrade	Fahrenheit	Centigrade	10% to 90% non-condensing	Feet	Meters
+32° to +113°	0° to +45°	-4° to +158°	-20° to +70°		< 10000	<3000

Dimensions, Weights, Mounting

Dimensions (WxHxD)		Weight		Mounting Type
Millimeters	Inches	Kilograms	Pounds	
442 x 44 x 375	17.4 x 1.7 x 14.76	5.3	11.6	Desktop, Rack

Voltage and Frequency

AC Input Voltage, Frequency and Power	
Voltage	100-240 VAC
Frequency	50~60 Hz

PoE

Ports	PoE Support
Ports 1-12	PoE/PoE+ (IEEE 802.3at)
Ports 13-24	PoE/PoE+/PoE++ (IEEE 802.3bt)
PoE Budget	740 Watts

Power Consumption

Power	Non-Loading (W)	Non-Loading (BTU/Hr)	PoE Full Loading (W)	PoE Full Loading (BTU/Hr)
110VAC	42.99	146.6	887.34	3025.83
220VAC	41.97	143.12	865.69	2952

MTBF

Temperature	Mean Time Between Failures
25°C	152962 Hours
50°C	39307 Hours

Certifications

Electromagnetic Emissions (EMC) and Safety
FCC Part 15 Class A NDAA compliant and TAA compliant UL Pending CE, EN55032, EN55035 CB (IECEE Certification Body Scheme)

Software Features

Layer 2 Switching	
Spanning Tree Protocol (STP)	<ul style="list-style-type: none"> Standard Spanning Tree 802.1d Rapid Spanning Tree (RSTP) 802.1w Multiple Spanning Tree (MSTP) 802.1s
Trunking	<ul style="list-style-type: none"> Link Aggregation Control Protocol (LACP) IEEE 802.3ad Static aggregation
VLAN	Supports up to 4K VLANs simultaneously (out of 4096 VLAN IDs). Port-based VLAN; 802.1Q tag-based VLAN; Protocol based VLAN; IP subnet-based VLAN; Private VLAN Edge (PVE); MAC-based VLAN; Q-in-Q (double tag) VLAN; GARP VLAN Registration Protocol (GVRP)

DHCP Relay	<ul style="list-style-type: none"> • Relay of DHCP traffic to DHCP server in different VLAN • Works with DHCP Option 82
IGMP Snooping	IGMP limits bandwidth-intensive multicast traffic to only the requesters. Supports 4024 512 multicast groups.
IGMP Querier	IGMP querier is used to support a Layer 2 multicast domain of snooping switches in the absence of a multicast router
IGMP Proxy	IGMP snooping with proxy reporting or report suppression actively filters IGMP packets to reduce load on the multicast router
MLD v1/v2 Snooping	Delivers IPv6 multicast packets only to the required receivers
Multicast VLAN Registration	MVR uses a dedicated manually configured VLAN, called the multicast VLAN, to forward multicast traffic over Layer 2 network in conjunction with IGMP snooping
Security	
Secure Shell (SSH)	SSH secures Telnet traffic in or out of the switch; SSH v1 and v2 are supported.
Secure Sockets Layer (SSL)	SSL encrypts the http traffic, allowing advanced secure access to the browser-based management GUI in the switch
IEEE 802.1X	<ul style="list-style-type: none"> • IEEE802.1X: RADIUS authentication, authorization and accounting, MD5 hash, guest VLAN, single/multiple host mode and single/multiple sessions • Supports IGMP-RADIUS based 802.1X • Dynamic VLAN assignment
Layer 2 Isolation Private VLAN Edge	PVE (also known as protected ports) provides L2 isolation between clients in the same VLAN. Supports multiple uplinks
Port Security	Locks MAC addresses to ports and limits the number of learned MAC address
IP Source Guard	Prevents illegal IP address from accessing a specific port in the switch
RADIUS / TACACS+	Supports RADIUS and TACACS+ authentication. Switch as a client.
Storm Control	Prevents traffic on a LAN from being disrupted by a broadcast, multicast, or unicast storm on a port
DHCP Snooping	A feature acts as a firewall between untrusted hosts and trusted DHCP servers
Loop Protection	Prevents unknown unicast, broadcast, multicast loops in Layer 2 switching.
Quality of Service (QoS)	
Hardware Queue	Supports 8 hardware queues
Scheduling	<ul style="list-style-type: none"> • Strict priority and weighted round-robin (WRR) • Queue assignment based on DSCP and class of service
Classification	<ul style="list-style-type: none"> • Port based • 802.1p VLAN priority based
Rate Limiting	<ul style="list-style-type: none"> • Ingress policer • Egress shaping and rate control • Per port

Management	
Port Mirroring	Traffic on a port can be mirrored to another port for analysis with a network analyzer or RMON probe. A single session is supported.
IEEE 802.1ab (LLDP)	Used by network devices for advertising their identities, capabilities, and neighbors on an IEEE 802ab local area network.
LLDP-MED	Supports LLDP-MED extensions per ANSI/TIA-1057 by the Telecommunications Industry Association (TIA).
Web GUI	Built-in switch configuration utility for browser-based device configuration
Dual Image	Independent primary and secondary images for backup while upgrading
UPnP	The Universal Plug and Play Forum was formed to standardize discovery and control of networked devices. See the Open Connectivity Foundation webpage .
DHCP Server	Support DHCP server to assign IP to DHCP clients
SNMP	SNMP v1, v2c, v3 with traps, and SNMP v 3 user-based security model (USM)
Firmware Upgrade	Web browser upgrade (HTTP/ HTTPs) and TFTP
NTP	Network Time Protocol (NTP) is a networking protocol for clock synchronization between computer systems over packet-switched
Other Management	HTTP/HTTPs; DHCP Client; Cable Diagnostics; Syslog; Telnet Client; SSH, IPv6 Management
Device Management System (DMS)	
Graphical Monitoring	<ul style="list-style-type: none"> • Topology view: Intuitive way to configure and manage switches and other devices with visual relations. • Floor view: Easily drag and drop PoE devices and help you to build smart workforces. • Map view: Efficiently drag and drop devices and monitor locations on Google Maps.
Find My Switch	The front panel LEDs flash for 15 seconds to visually identify the switch.
Traffic Monitoring	Display a visual chart of network traffic of all devices and monitor every port at any time.
Troubleshooting	Network diagnostic between master switch and devices. Supports protection mechanism, such as rate-limiting to protect your devices from brute-force downloading.
Power over Ethernet (PoE)	
Port Configuration	Supports per-port PoE configuration function.
PoE Scheduling	Supports per-port PoE scheduling to turn on/off the PoE powered devices (PDs).
Auto Power Reset	Automatically monitors and reboots PD when no response to ICMP is received.
Power Delay	The switch provides power to the PDs based on delay time when PoE switch boots up, to protect switch from misuse of the PDs.
Always on PoE	Ensures there is always PoE power to the attached PDs so a switch reboot or firmware upgrade will not disrupt power to the PDs allowing camera or WAPs to continue functioning.

PercepXion and LPM	
PercepXion	Centralized Management Software for Lantronix devices. <ul style="list-style-type: none"> • Firmware upgrades via PercepXion • Backup / restore of switch configurations via PercepXion • Switch port information via PercepXion • PoE telemetry / statistics via PercepXion • Web Connect from PercepXion to switch (via PercepXion open switch web GUI to view DMS Topology, etc.) • PercepXion Geo Location
LPM	Lantronix Provisioning Manager allows easy administration of Lantronix devices. LPM lets you quickly update firmware, update configuration, and provision one or more devices simultaneously. See the LPM product page for details.

Applications

- IP surveillance, supplying power and data to IP cameras
- Connecting and remotely powering wireless access points
- Monitoring/managing attached powered devices from various vendors



PoE Lighting



Smart Building



Security & Surveillance



Digital Signage

About This Manual

This manual describes how to install, configure, and troubleshoot the SM24TBT4XPA switch, including how to:

- Install the switch.
- Initially set up the switch.
- Check switch status by reading the LED behavior.
- Reset the switch or restore the switch to factory defaults.
- Troubleshoot switch installation.

Note that this manual may provide links to third party web sites for which Lantronix is not responsible.

Related Manuals

Related manuals include:

- SM24TBT4XPA Quick Start Guide, 33875
- SM24TBT4XPA Web User Guide, 33877
- SM24TBT4XPA CLI Reference, 33878
- Release Notes (version specific)

For Lantronix Drivers, Firmware, Manuals, etc. go to the Lantronix [Technical Resource Center](#).

2. Product Description

Overview

This chapter describes the SM24TBT4XPA switch, including descriptions of:

- Front and Back Panels.
- How to reset the switch or restore the switch to factory defaults.
- MODE/RESET button operation and functions.
- LED operation.

Front Panel

The front panels are similar except for port counts.

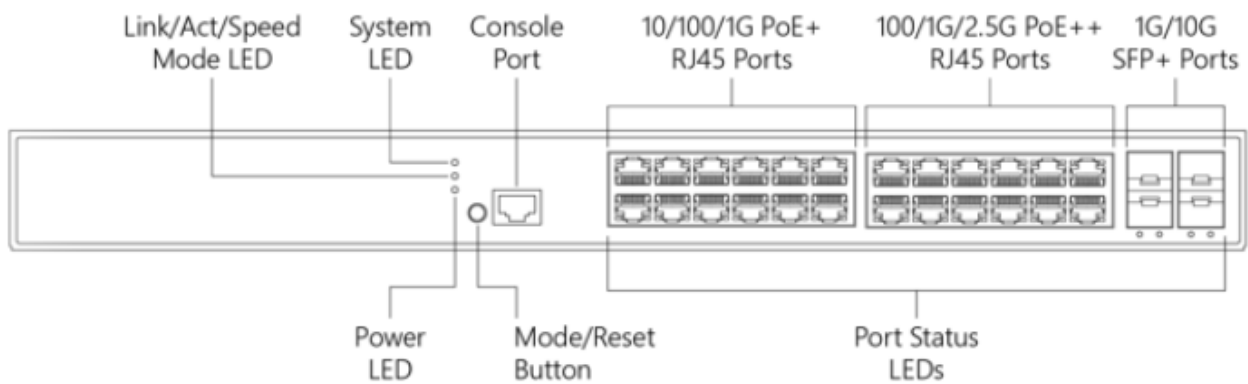

Figure 1: SM24TBT4XPA Front Panel

Back Panel

The back panel is shown below.

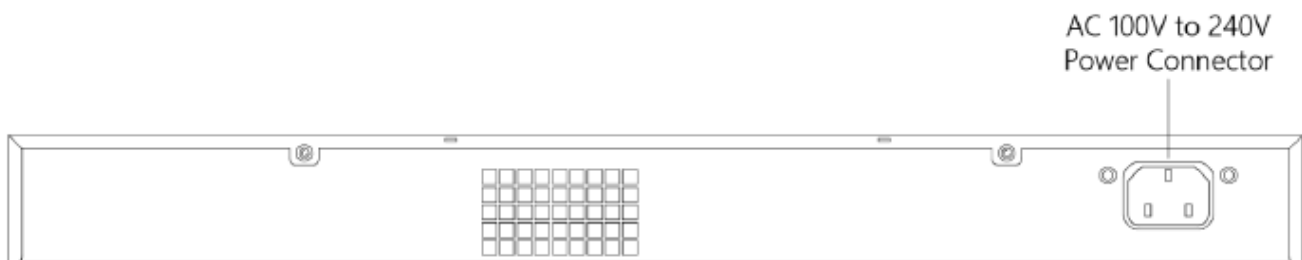

Figure 2: SM24TBT4XPA Back Panel

LED Descriptions

The LEDs on the front panel provide switch status checking and monitoring. There are four types of LEDs as follows:

System LED: Indicates if the system is ready or not or indicates if there is a system alarm triggered for troubleshooting.

Power LEDs: Indicates if the switch is powered up correctly or not.

PoE LED: Indicates the status of PoE.

Port Status LEDs: indicates the current status of each RJ45/SFP+ port. Users can check these LEDs to understand the port status.

The LED indicators are described in the following tables.

Table 1: System LED

LED	Color	State	Description
System	Green	On	The switch is powered ON correctly.
		Off	The switch is not receiving power.
	Red	On	An abnormal state, such as exceeding operating temperature range, has been detected in the switch.

Table 2: Mode LEDs

LED	Color	State	Description
Link/Act/Speed	Green	On	The Port Status LEDs display link status, network activity, and speed of each port.
PoE	Green	On	The RJ45 Port Status LEDs display PoE powering status of each port.

By pressing the **MODE/RESET** button for less than 2 seconds to change LED modes (Link/Act/Speed Mode or PoE Mode) you can check the port status by reading the LED behaviors per the table below.

Table 3: Port Status LEDs

When Link/Act/Speed Mode LED Lit			
LED	Color	State	Description
RJ45 Ports (10M/100M/1 G PoE+) (Left side ports 1-12)	Green	On	The port is enabled and established a link to connected device, and the connection speed is 1000Mbps.
	Green	Blinking	The port is transmitting/receiving packets, and the connection speed is 1000Mbps.
	Amber	On	The port is enabled and established a link to connected device, and the connection speed is 10/100Mbps.
	Amber	Blinking	The port is transmitting/receiving packets, and the connection speed is 10/100Mbps.
	--	Off	The port has no active network cable connected, or it has not established a link to connected device. Otherwise, the port may have been disabled via the switch UI.
RJ45 Ports (100M/1G/2.5 G PoE++) (Right side ports 13-24)	Green	On	The port is enabled and established a link to connected device, and the connection speed is 2.5Gbps.
	Green	Blinking	The port is transmitting or receiving packets and the connection speed is 2.5Gbps.
	Amber	On	The port is enabled and has established a link a link to a connected device and the connection speed is 100/1000Mbps.
	Amber	Blinking	The port is transmitting or receiving packets and the connection speed is 1000/1000Mbps.
	--	Off	The port has no active network cable connected, or it has not established a link to connected device. Otherwise, the port may have been disabled via the switch UI.
1G/10G SFP+ Ports (ports 25-28)	Blue	On	The port is enabled and established a link to connected device, and the connection speed is 10Gbps.
	Blue	Blinking	The port is transmitting/receiving packets, and the connection speed is 10Gbps.
	Green	On	The port is enabled and established a link to connected device, and the connection speed is 1Gbps.
	Green	Blinking	The port is transmitting/receiving packets, and the connection speed is 1Gbps.
	--	Off	The port has no active network cable connected, or it has not established a link to connected device. Otherwise, the port may have been disabled via the switch UI.

MODE/RESET Button

By pressing the MODE/RESET button for a certain period of time, you can perform these tasks:

- **Reset the Switch:** to reboot and get the switch back to the previous configuration settings saved. The First Time Wizard displays again after pressing the MODE/RESET button.
- **Restore the Switch to Factory Defaults:** to restore the original factory default settings back to the switch.

Note: Based on the table below, you can tell which task is being performed by reading the LED behaviors while pressing the MODE/RESET button. Once the LEDs are correctly displayed, you may release the button.

Table 4: MODE/RESET Button Descriptions

Task to Perform	Press Button for ..	SYS LED Behavior	Port Status LED Behavior
Reset the Switch	2 ~ 7 seconds	Blinking Green	ALL LEDs are OFF.
Restore to Factory Defaults	7 ~ 12 seconds	Blinking Green	ALL LEDs Stay ON.

Press the MODE/RESET button until all port LEDs light, then release the MODE/RESET button. This will set the switch back to its factory default IP address. You can then log back in to display the First Time Wizard.

The First Time Wizard will only display when you use the hardware MODE/RESET button to reset the switch (press and hold the MODE/RESET button for over 10 seconds; when all of the LEDs light, then release the button).

3. Installation

Package Contents

Carefully unpack the package contents. Make sure no items are missing or damaged. Please save the packaging for possible future use.

- The Switch
- AC Power cord (country specific)
- Four adhesive rubber feet
- Printed Quick Start Guide
- Mounting kit
- RJ45 to DB9 Serial Console Cable

Caution: The switch is an indoor device. If it is to be used with outdoor devices such as outdoor IP cameras or outdoor Wi-Fi APs, then you are strongly suggested to install a surge protector or surge suppressor to protect the switch.



Mounting the Switch in a 19-inch Rack

Step 1: Attach the mounting brackets to both sides of the chassis. Insert screws and tighten them with a screwdriver to secure the brackets.

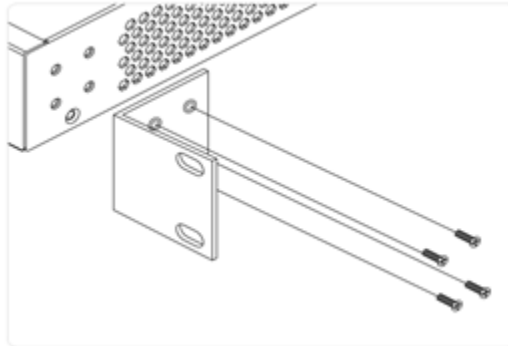

Figure 3: Attaching Brackets to the Switch

Step 2: Place the switch on a rack shelf in the rack. Push it in until the oval holes in the brackets align with the mounting holes in the rack posts.

Step 3: Attach the brackets to the posts. Insert screws and tighten them.

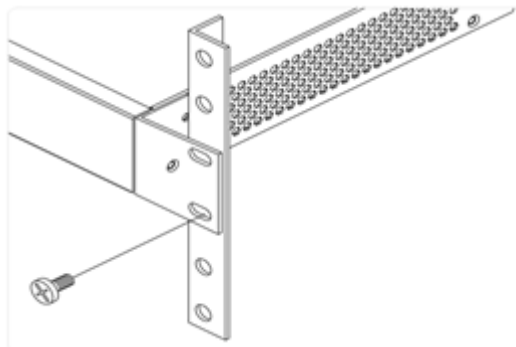

Figure 4: Attaching Brackets to the Rack Post

Mounting the Switch on Desk or Shelf

Step 1: Verify that the workbench is sturdy and reliably grounded.

Step 2: Attach the four adhesive rubber feet to the bottom of the switch.

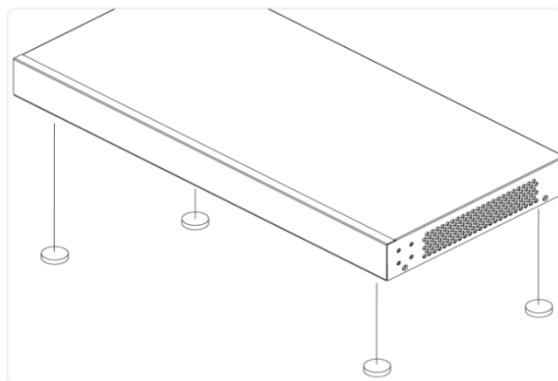

Figure 5: Attaching the Rubber Feet

Connecting PoE Devices

10M/100M/1G PoE+ Ports: Connect 1-12 IEEE 802.3at PoE+ PDs to ports 1-12.

10M/100M/1G PoE++ Ports: Connect 1-12 IEEE 802.3bt PoE++ PDs to ports 13-24.

1G/10G SFP Ports: Connect 1-4 1G/10G SFP (Fiber) devices to ports labeled 25-28.

Caution: If utilizing the PoE Force mode feature, only connect PDs which support power input in the 48~56V range to prevent damage to PDs. When the port is changed to Force mode, the port's PoE LED lights immediately. See the *Web User Guide* for details.

Caution: PoE device components may fail due to transient voltage spikes on the PoE line. It is strongly suggested that a surge suppressor be used on each PoE port, especially in areas with frequent lightning and other types of interference.

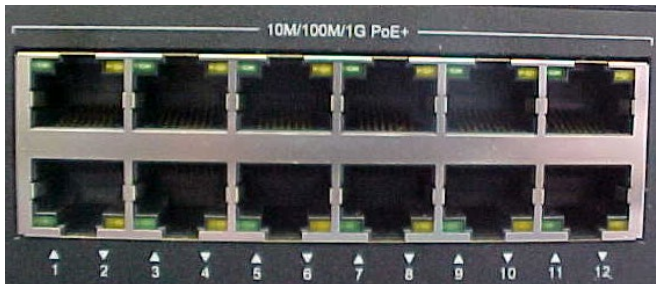

10M/100M/1G PoE+ Ports

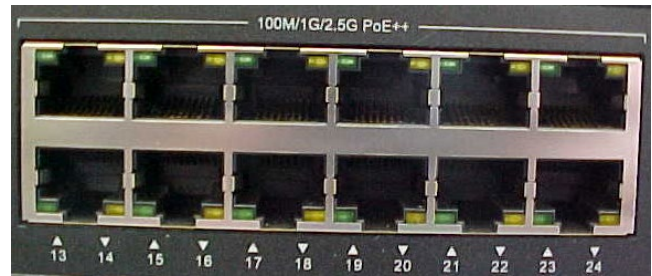

100M/1G/2.5G PoE++ Ports



1G/10G SFP Ports

Figure 6: Switch Ports

Installing SFP+ Modules

You can install or remove a mini-GBIC SFP+ module from an SFP+ port without having to power off the switch.

Note: See the related SFP device manual for important Safety warnings. See the Lantronix [SFP page](#) for our full line of SFP transceivers. See the [FOA webpage](#) for additional information. The Fiber Optic Association, Inc. is an international non-profit educational association chartered to promote professionalism in fiber optics through education, certification and standards.

Note: The SFP+ ports should use UL Listed Optional Transceiver product, Rated 3.3Vdc, Laser Class 1.

Step 1: Insert the module into the SFP port.

Step 2: Press firmly to ensure that the SFP module seats into the connector.

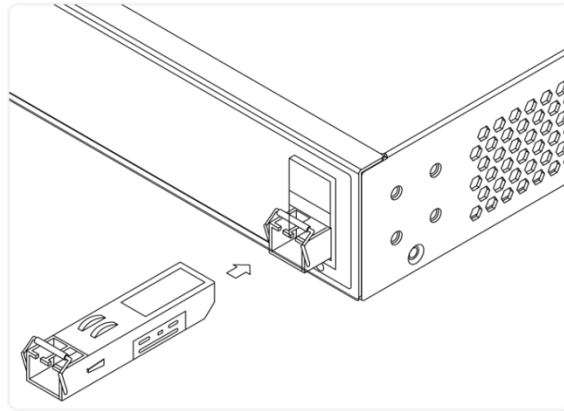

Figure 7: Installing an SFP+ Module into an SFP+ Port

Connecting the AC Power Cord

The switch ships with a country specific AC Power cord. To order the corresponding country specific power cord, add the Country Code extension to the end of the SKU (e.g., SM24TBT4XPA-NA = North America, -LA = Latin America, -EU = Europe, -UK = United Kingdom, -SA = South Africa, -JP = Japan, -OZ = Australia, -BR = Brazil).

Caution: The switch is an indoor device. If it is to be used with outdoor devices such as outdoor IP cameras or outdoor Wi-Fi APs, then you are strongly suggested to install a surge protector or surge suppressor to protect the switch.

Step 1: Connect the AC power cord to the AC power receptacle of switch.

Step 2: Connect the other end of the AC power cord to the AC power outlet. When connecting to AC power, avoid outlets connected to a wall switch.

Step 3: Check the SYS LED. If it is ON, the power connection is correct.

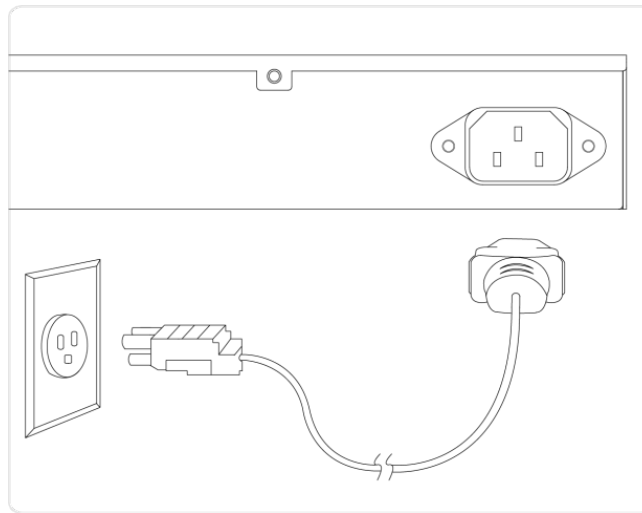

Figure 8: Connecting AC Power Cord

4. Initial Switch Setup

Initial Switch Setup via Web Browser

For the initial setup, you must reconfigure your PC's IP address and subnet mask so as to make sure the PC can communicate with the switch. After changing PC's IP address (for example, 192.168.1.250), then you can access the Web interface of the switch using the switch's default IP address as shown below.

The initial switch configuration via web browser procedure is as follows:

Note: The switch's factory default IP address is **192.168.1.77** and the factory default Subnet Mask is **255.255.255.0**.

1. Power up the PC that you will use for the initial configuration. Make sure the PC has an Ethernet RJ45 connector to be connected to the switch via standard Ethernet LAN cable.
2. Change the PC's IP address and Subnet Mask so that it can communicate with the switch.
3. Power up the switch to be initially configured and wait until it has finished its start-up process.
4. Connect the PC to any port on the switch using a standard Ethernet cable, and check the port LED on the switch to make sure the link status of the PC is OK.
5. Run a Web browser on the PC; enter the factory default IP address to access the switch Web UI. If your PC is configured correctly, you will see the Login page of the switch as shown below.



Figure 9: Web UI Login page

If you do not see the above login page, perform these steps:

- Refresh the web page.
 - Check to see if there is an IP conflict issue.
 - Clean browser cookies and temporary internet files.
 - Check your PC settings again and repeat step 2.
6. Enter the factory default username (**admin**) and password (**admin**) in login page.
 7. Click "Login" to log into the switch.

Initial Switch Configuration via Web Browser

When you log in to the switch the first time, a First Time Wizard displays. On subsequent power ups, you can perform switch configuration using a web browser. See the *SM24TBT4XPA Web User Guide* for more information.

Initial Switch Setup via CLI

The CLI (Command Line Interface) can be accessed via telnet or SSH. A brief description of the network connection is provided below.

The RJ-45 to DB9 Serial Console cable (option) is used for connecting a terminal or PC/terminal emulator to the Switch's RJ-45 port to access the CLI.

The switch factory defaults are IP Address: 192.168.1.77, User Name: admin, and Password: admin.

The procedure below is typical; switch installation may vary due to site differences in OSEs, cabling, cable adapters, connections, tools, and setup.

1. Connect one end of an RJ-45 cable to a terminal or a PC/terminal emulator.
2. Attach the other end of the cable to the switch CONSOLE port.
3. Run a connectivity tool on the PC.
4. At 'Com Port Properties' (or similar) menu set: Baud rate=115200, Stop bits=1, Data bits=8, Parity=N, Flow control=none.
5. Enter the factory default username (admin) and password (admin) and press Enter to access the switch CLI via the connectivity tool.

```

SM24TBT4XPA# show system
Model Name          : SM24TBT4XPA
System Description  : Managed Switch, (12) 100/1000Base X SFP ports + (2)
                    : 1G/10G SFP+ with (2) 10/100/1000Base-T
Location            :
Contact             :
System Name         : SM24TBT4XPA
System Date         : 2018-01-02T16:25:22+00:00
System Uptime       : 1d 16:25:23
Bootloader Version  : v0.3
Firmware Version    : v7.10.1329 2018-01-04
Hardware Version    : v1.01
Mechanical Version  : v1.01
Serial Number       : 0000100009000001
MAC Address         : 00-c9-12-49-38-b6
Memory              : total=17700 Kbytes, Free=55763 Kbytes, Max=55121 K
Bytes              : 0x00000000-0x1fffffff: 512 x 0x10000 blocks
Fan Speed           : 7033 (rpm)
Powers              : DC Power On 14.00V ; DC Power On 0.00W
Temperature 1      : 36(C) ; 96(F)
Temperature 2      : 31(C) ; 87(F)
SM24TBT4XPA#

```

See the PC, terminal, and/or connectivity tool documentation and helps for related information. See the *CLI Reference* for switch configuration via the CLI.

5. Troubleshooting, Support, and Compliance

Troubleshooting

The following table provides steps to troubleshoot problems by taking actions based on the suggested solutions.

Table 5: Troubleshooting Procedure

Symptom	Possible Cause	Suggested Solution
SYSTEM LED is Off	The switch is not receiving power.	<ol style="list-style-type: none"> 1. Check if correct power cord is connected firmly to the switch and to the AC outlet socket. 2. Perform power cycling the switch by unplugging and plugging the power cord back into the switch. 3. If the LED is still off, try to plug power cord into different AC outlet socket to make sure correct AC source is supplied.
SYSTEM LED is Red	An abnormal state was detected by the switch.	Check the system log to understand the abnormal state (e.g., exceeding operating temperature range) and take corresponding actions to resolve.
RJ45 ports left side Status LED is Off	The port is not connected, or the connection is not working.	<ol style="list-style-type: none"> 1. Check if the cable connector plug is firmly inserted and locked into the port at both the switch and connected device. 2. Make sure the connected device is up and running correctly. 3. If the symptom still exists, try different cable or different port to tell if it is related to the cable or specific port. 4. Check if the port is disabled in the configuration settings via the Web user interface.
RJ45 ports right side LED is Off	The port is not supplying power	<ol style="list-style-type: none"> 1. Check if the cable connector plug is firmly inserted and locked into the port at both the switch and connected device. 2. Make sure the correct Ethernet cables are used. 3. If symptom still exists, try different cable or different port to identify if it is related to the cable or specific port. 4. Check if the port is disabled in the configuration settings via the Web user interface.

PoE Modes and Compliance

PoE Deployment in Environments A and B

IEEE802.3at-2009 defines two deployment environments in section 33.4.1:

Environment A: when both PSE and PD are located indoors, inside the same building. In this environment, there must be electrical isolation between the PoE circuitry and the data circuitry inside a PSE. Multi-port PSE's can all share the same ground isolation. Environment A is therefore an indoor PSE –indoor PD environment (a.k.a. indoor/indoor).

Environment B: when the PSE and PD are not located in the same building. In this environment there needs to be electrical isolation between PoE and data, as well as between every port in a multi-port PSE. This isolation between ports requirement de facto determines a completely separate power supply per port, which makes multi-port PSEs for outdoor PD deployment impractical. Environment B is therefore an indoor PSE-outdoor PD (a.k.a. indoor/outdoor) or outdoor PSE-outdoor PD (a.k.a. outdoor/outdoor) environment.

This means only single-port PSEs should normally be used when PDs are deployed outdoors. In summary, the PD-PSE environment is one of these three combinations:

1. PoE Source is indoor, PD is indoor (Env. A)
2. PoE Source is indoor, PD is outdoor (Env. B)
3. PoE Source is outdoor, PD is outdoor (Env. B)

Option 3 is the most challenging environment since both the PD and PSE are installed outdoors.

Caution: The switch is an indoor device. If it is to be used with outdoor devices such as outdoor IP cameras or outdoor Wi-Fi APs, then you are strongly suggested to install a surge protector or surge suppressor to protect the switch. The switch is compliant with 802.3at in Environment A when using an isolated power supply. For 802.3at Environment B applications, i.e., building to building, copper to copper endpoint connections: 1) use an Ethernet network isolator module (PoE disabled), or 2) use mid-span injector(s) between this switch's PSE port and link partner PD port.

Mode A vs. Mode B

Alternative A, also known as Mode A, uses the data pairs of an Ethernet link to deliver power. Data Pairs include pins 1,2 and 3,6. PSEs using Mode A supply a positive voltage to pins 1 and 2. Alternative B, also known as Mode B, uses the spare pairs to deliver power. Spare Pairs include pins 4,5 and 7,8.

802.3af/at Standard "compliant" vs "compatible" PDs

Knowing the difference between PoE "compliant" and "compatible" devices can help avoid interoperability and connectivity issues. Compliant PoE devices and compatible PoE devices are not held to the same 802.3af/at standard:

- 802.3af/at "compliant" PDs fulfill the IEEE strict requirement to support both Mode A and Mode B power modes.
- 802.3af/at "compatible" PDs typically can provide power using only Mode B.

Typical PD Power Requirements

- 1.8 Watts: Lantronix' M/GE-ISW-SFP-01-PD (Class 1 Powered Device (0.44 - 3.84 Watts).
- 13W: IP Camera, VoIP Phone, Wireless Access Point, Networked Audio.
- 30W: IP Telephone, WiMAX Access Point, PTZ Camera, Remote Computer Terminal.
- 60W : Door Access System, Video Phone, Thin Client.
- 100W: Digital Signage Display, Point-of-Sale System, LCD TV, Computer Monitor.
- 200W: Larger TV, Larger Display, Larger Monitor, Laptop.

After eliminating basic network factors, ask your PD vendor for the PD's power supply mode and polarities supported and exact power consumption.

Calculate PoE Power Budget

To calculate how many 802.3at devices the unit supports, divide the Total PoE Budget (130 Watts) by 30 Watts. To calculate the maximum number of 802.3af devices, divide the Total PoE Budget (130 Watts) by 15.4 Watts.

Mixing PoE and Non-PoE Devices

You can mix PoE and non-PoE devices on the same PoE switch (i.e., you can put PCs on the same PoE switch as a SIP phone or a VOIP phone). The PSE (your switch) will only send power if requested by the PD.

Ethernet and PoE Intra-Building Cabling Warnings

1. Ethernet cables are intended for intrabuilding use only. Connecting your Lantronix switch directly to Ethernet cables that run outside the building in which the switch is housed will void the user's warranty and could create a fire or shock hazard.
2. PoE cables are intended for intrabuilding use only. Connecting your Lantronix switch directly to PoE cables that run outside the building in which the switch is housed will void the user's warranty and could create a fire or shock hazard.
3. For outdoor PoE applications, we recommend using hardened PoE+ Injector/Converter.

Legacy PD Detection / Capacitor Detection

Legacy PDs refers to powered devices manufactured before the IEEE standard was finalized and do not have the expected PD signature required by the PSE's detection signal. Such PDs usually feature large capacitance as the detection signature that does not completely comply with the 802.3af specs. By enabling this option, the switch will probe for legacy PDs and if a legacy PD is detected, the switch will provide power to the PD.

Troubleshooting PoE Problems

1. Get as much detail as possible regarding the symptom, including any system messages from the PoE switch. For example, does a PD not power up at all, or does it power up briefly and then power down?
2. Determine if the trouble occurred on initial installation or after the PD had been working normally?
3. If the trouble started after the PD was working, what changed? Any hardware or software changes?
4. Verify that the port is not shut down, disabled, or errored.
5. Verify that the Ethernet cable from the PD to the switch port is good.
6. Verify that the total cable length from the switch front panel to the connected PD is not more than 100 meters. Some of the power from the switch port is dissipated in the cable due to wire resistance, especially on cables as long as 100 meters. Only the remaining power is available to the PD. The 100-meter limit for twisted-pair Ethernet cable assumes **a)** not more than four RJ-45 connection points in the transmission path, **b)** 90 meters of solid-strand Category 5 or 5e, and **c)** 10 meters of flexible multistrand cable (2 to 5 meters of multistrand Category 5 patch cords).
7. Verify that the PSE switch power budget can power the PD. If the switch power budget is depleted, additional PDs will not power-on when connected to a PoE port. Verify that the switch power budget (available PoE) is not depleted before or after the PD is connected. Verify that enough power is available for the PD type.
8. Verify if non-powered Ethernet devices can establish an Ethernet link on any port and that PoE devices do not power up on the same port.
9. Review alarms reported previously by system messages.
10. If a working IP Phone or WAP intermittently reloads or disconnects from inline power, verify all electrical connections from the switch to the PD. An unreliable connection results in power interruptions and intermittent PD operation, such as PD disconnects and reloads.
11. Check for changes in the electrical environment at the switch site. What is happening at the PD when the disconnect occurs? Check for error messages reported by the switch at the same time of the disconnect.
12. Pre-standard and post-standard VoIP phones may use different detection and connect / disconnect methods. Note that PD detection occurs when an Ethernet device is first connected to a PoE port. If a non-PoE device

is connected to a PoE port, detection is deactivated. If the non-PoE device is later disconnected and replaced by a PD, the switch may not detect it immediately.

13. Verify that the PD is not causing an overcurrent condition on the port. Specifically: does the VoIP phone initially power on and then disconnect? If so, the problem may be an initial current surge that exceeds a current-limit threshold for the switch port. Some PDs may have excessive “surge in” current when first connected to a PoE port. The switch initially provides power to the port, and then quickly removes power due to a momentary overcurrent condition. The PD starts to power up, but then quickly powers down.
14. Most PoE switches have voltage and current regulators that detect an overcurrent threshold and disconnect power from the line. This prevents excessive current from being delivered by the PoE port, which could possibly result in damage to port-level components.
15. A variety of disturbances on the AC power line (mains) can cause odd PoE problems. The power supplies in various switches and PDs can react uniquely to AC input disturbances. AC disruption problems are usually temporary or one-time occurrences. For example, a specific switch or PD may reboot due to an AC power problem, while other switches or PDs may show a greater immunity to the problem. This is a typical occurrence during lightning storms or AC power maintenance. In a worst-case scenario, a PoE power supply may appear to shut down, with no PoE output voltage to any port. It's possible the switch's Ethernet functions appear normal, and only the PoE functions are disrupted or degraded, or the switch may power down completely due to the AC disturbance. PDs may exhibit unusual behavior. In such cases, power cycle the switch (unplug the switch, wait at least three seconds, then plug it back in. This will ensure a total system reset that should restore normal operation.
16. Check if related features (LLDP mode, CDP mode) are enabled.

Labels

The product and package labels contain important information to record before contacting Technical Support.



Product Label



Package Label

Recording Device and System Information

After performing the troubleshooting procedures, and before calling or emailing Technical Support, please record as much information as possible to help the Tech Support Engineer.

1. Select the SM24TBT4XPA **Configuration > System > Information** menu path. From the CLI, use the **show** commands needed to gather the information below or as requested by the Tech Support Engineer.

2. Record **Model Information**:
Model Name: _____
Hardware Version: _____ Mechanical Version: _____
Firmware Version: _____ System Date: _____

3. Record the **LED Status**: _____

4. Provide additional information to your Tech Support Specialist. See the “Troubleshooting” section above.
Your Lantronix service contract number: _____
Describe the failure: _____

Describe any action(s) already taken to resolve the problem (e.g., changing mode, rebooting, etc.):

The serial and revision numbers of all involved Lantronix products in the network: _____

A description of your network environment (layout, cable type, etc.): _____

The device history (i.e., have you returned the device before, is this a recurring problem, etc.): _____

Any previous Return Material Authorization (RMA) numbers: _____

Compliance Information

FCC Regulations

This equipment has been tested and found to comply with the limits for a Class A digital device, pursuant to part 15 of the FCC rules. These limits are designed to provide reasonable protection against harmful interference when the equipment is operated in a commercial environment. This equipment generates, uses, and can radiate radio frequency energy and, if not installed and used in accordance with the instruction manual, may cause harmful interference to radio communications.

Operation of this equipment in a residential area is likely to cause harmful interference, in which case the user will be required to correct the interference at the user's own expense.

This device complies with part 15 of the FCC Rules. Operation is subject to the following two conditions: (1) This device may not cause harmful interference, and (2) this device must accept any interference received, including interference that may cause undesired operation.

Standards: 47 CFR FCC Part 15, Subpart B, Class A
 ANSI C63.4:2014
 ANSI C63.4a-2017

Canadian Regulations

This digital apparatus does not exceed the Class A limits for radio noise for digital apparatus set out on the radio interference regulations of the Canadian Department of Communications.

Le présent appareil numérique n'émet pas de bruits radioélectriques dépassant les limites applicables aux appareils numériques de la Class A prescrites dans le Règlement sur le brouillage radioélectrique édicté par le ministère des Communications du Canada.

Declaration of Conformity

Manufacture's Name: Lantronix, Inc.

Manufacture's Address: 48 Discovery, Suite 250, Irvine, California 92618 USA

Declares that the products: SM24TBT4XPA

Conform to the following Product Regulations:

CE, FCC Part 15 Class A

Standards: 47 CFR FCC Part 15, Subpart B, Class A
ANSI C63.4:2014
ANSI C63.4a-2017

UL Pending

EN 55032: 2015 +A11:2020 / CISPR 32:2015 + Cor 1:2016, Class A

AS/NZS CISPR 32: 2015 +AMD1:2020 / CISPR 32: 2015+AMD1:2019 ED. 2.0, Class A

CISPR 32: 2019 ED. 2.1, Class A

EN 61000-3-2:2014, Class A

EN IEC 61000-3-2:2019+A1:2021, Class A

EN 61000-3-3: 2013+A1:2019+A2:2021

EN 55035:2017 +A11:2020

EN 61000-4-2:2009 / IEC 61000-4-2:2008 ED. 2.0

EN IEC 61000-4-3:2020 / IEC 61000-4-3:2020 ED. 4.0

EN 61000-4-4:2012 / IEC 61000-4-4:2012 ED. 3.0

EN 61000-4-5:2006 / IEC 61000-4-5:2005 ED. 2.0

EN 61000-4-6:2014+AC:2015 / IEC 61000-4-6:2013 ED. 4.0

EN 61000-4-8:2010 / IEC 6100-4-8:2009 ED. 2.0

EN IEC 61000-4-11: 2020+AC:2020 / IEC 61000-4-11:2020 ED. 3.0

With the technical construction on file at the above address, this product carries the CE Mark

I, the undersigned, hereby declare that the equipment specified above conforms to the above Directive(s) and Standard(s).

Place: Irvine, California

Date: June 20, 2024

Signature: *Eric Bass*

Full Name: Eric Bass

Position: Vice President of Engineering

UKCA Certificate of Conformity

SM24TBT4XPA_UKCA COC_CEBEFT-WTW-P24050643C-1.pdf

CERTIFICATE OF CONFORMITY		 BUREAU VERITAS
Product	: 12 ports 10M/100M/1G PoE+ RJ45 + 12 ports 100M/1G/2.5G PoE++ RJ45 + 4 ports 10G SFP+ (PoE 740W)	UK CA
Brand	: LANTRONIX	
Model No.	: SM24TBT4XPA	
Applicant	: Lantronix, Inc.	
Report No.	: CEBEFT-WTW-P24050643	
<p>We, Bureau Veritas Consumer Products Services (H.K.) Ltd., Taoyuan Branch, declare that the equipment above has been tested in our facility and found compliance with the requirement limits of applicable standards, in accordance with the Electromagnetic Compatibility Regulations 2016 (S.I. 2016/1091). The test record, data evaluation and Equipment Under Test (EUT) configurations represented herein are true and accurate under the standards herein specified.</p>		
<hr/> <p>BS EN 55032: 2015+A11:2020, Class A BS EN IEC 61000-3-2:2019+A1:2021, Class A BS EN 61000-3-3: 2013+A1:2019+A2:2021 BS EN 55035:2017 +A11:2020 BS EN 61000-4-2:2009 / IEC 61000-4-2:2008 ED. 2.0 BS EN IEC 61000-4-3:2020 / IEC 61000-4-3:2020 ED. 4.0 BS EN 61000-4-4:2012 / IEC 61000-4-4:2012 ED. 3.0 BS EN 61000-4-5:2006 / IEC 61000-4-5:2005 ED. 2.0 BS EN 61000-4-6:2014 / IEC 61000-4-6:2013 ED. 4.0 BS EN 61000-4-8:2010 / IEC 61000-4-8:2009 ED. 2.0 BS EN IEC 61000-4-11:2020 / IEC 61000-4-11:2020 ED. 3.0</p>		
<p>NOTE: The above BS EN/IEC basic standards are applied with latest version if customer has no special requirement.</p>		
<p> Jim Hsiang / Associate Technical Manager 2024/6/6</p>		
<p>No. 47-2, 14th Ling, Chia Pau Vil., Lin Kou Dist., New Taipei City, Taiwan Tel: 886-2-26052180 Fax: 886-2-26051924 http://ee.bureauveritas.com.tw E-Mail: service.adt@tw.bureauveritas.com</p>		

CE Certificate of Conformity

SM24TBT4XPA_CE COC_CEBEFT-WTW-P24050643C.pdf

CERTIFICATE OF CONFORMITY



Product : 12 ports 10M/100M/1G PoE+ RJ45 + 12 ports 100M/1G/2.5G PoE++ RJ45 +
4 ports 10G SFP+ (PoE 740W)

Brand : LANTRONIX

Model No. : SM24TBT4XPA

Applicant : Lantronix, Inc.

Report No. : CEBEFT-WTW-P24050643



We, Bureau Veritas Consumer Products Services (H.K.) Ltd., Taoyuan Branch, declare that the equipment above has been tested in our facility and found compliance with the requirement limits of applicable standards, in accordance with the Directive 2014/30/EU. The test record, data evaluation and Equipment Under Test (EUT) configurations represented herein are true and accurate under the standards herein specified.

EN 55032:2015 +A11:2020 / CISPR 32:2015 +Cor 1:2016, Class A
AS/NZS CISPR 32: 2015 +AMD1:2020 / CISPR 32: 2015+AMD1:2019 ED. 2.0, Class A
CISPR 32: 2019 ED. 2.1, Class A
EN 61000-3-2:2014, Class A
EN IEC 61000-3-2:2019+A1:2021, Class A
EN 61000-3-3: 2013+A1:2019+A2:2021
EN 55035:2017 +A11:2020
EN 61000-4-2:2009 / IEC 61000-4-2:2008 ED. 2.0
EN IEC 61000-4-3:2020 / IEC 61000-4-3:2020 ED. 4.0
EN 61000-4-4:2012 / IEC 61000-4-4:2012 ED. 3.0
EN 61000-4-5:2006 / IEC 61000-4-5:2005 ED. 2.0
EN 61000-4-6:2014+AC:2015 / IEC 61000-4-6:2013 ED. 4.0
EN 61000-4-8:2010 / IEC 61000-4-8:2009 ED. 2.0
EN IEC 61000-4-11: 2020+AC:2020 / IEC 61000-4-11:2020 ED. 3.0

NOTE: The above EN/IEC basic standards are applied with latest version if customer has no special requirement.

Jim Hsiang

Jim Hsiang / Associate Technical Manager
2024/6/6



No. 47-2, 14th Ling, Chia Pau Vil., Lin Kou Dist., New Taipei City, Taiwan
Tel: 886-2-26052180 Fax: 886-2-26051924
<http://ee.bureauveritas.com.tw> E-Mail: service.adt@tw.bureauveritas.com

FCC Certificate of Conformity

SM24TBT4XPA_FCC COC_FDBEFT-WTW-P24050643C.pdf



CERTIFICATE OF CONFORMITY

Standard: 47 CFR FCC Part 15, Subpart B, Class A

ANSI C63.4:2014

ANSI C63.4a-2017

Report No.: FDBEFT-WTW-P24050643

Product: 12 ports 10M/100M/1G PoE+ RJ45 + 12 ports 100M/1G/2.5G PoE++ RJ45 + 4 ports 10G SFP+ (PoE 740W)

Brand: LANTRONIX

Model No.: SM24TBT4XPA

Received Date: 2022/1/26

Test Date: 2022/1/28 ~ 2022/2/7

Issued Date: 2024/6/6

Applicant: Lantronix, Inc.

Address: 48 Discovery, Suite 250 Irvine, CA 92618 USA

Issued By: Bureau Veritas Consumer Products Services (H.K.) Ltd., Taoyuan Branch
Lin Kou Laboratories

Lab Address: No. 47-2, 14th Ling, Chia Pau Vil., Lin Kou Dist., New Taipei City, Taiwan

Test Location: No. 47-2, 14th Ling, Chia Pau Vil., Lin Kou Dist., New Taipei City, Taiwan

FCC Registration /

Designation Number: 418586 / TW1078

Approved by: Jim Hsiang, **Date:** 2024/6/6
Jim Hsiang / Associate Technical Manager

This test report consists of 27 pages in total. It may be duplicated completely for legal use with the approval of the applicant. It should not be reproduced except in full, without the written approval of our laboratory. The test results in the report only apply to the tested sample. The test results in this report are traceable to the national or international standards.



Prepared by : Ivy Lin / Specialist

This report is governed by, and incorporates by reference, the Conditions of Testing as posted at the date of issuance of this report at <http://www.bureauveritas.com/home/about-us/our-business/cps/about-us/terms-conditions/> and is intended for your exclusive use. Any copying or replication of this report to or for any other person or entity, or use of our name or trademark, is permitted only with our prior written permission. This report sets forth our findings solely with respect to the test samples identified herein. The results set forth in this report are not indicative or representative of the quality or characteristics of the lot from which a test sample was taken or any similar or identical product unless specifically and expressly noted. Our report includes all of the tests requested by you and the results thereof based upon the information that you provided to us. Measurement uncertainty is only provided upon request for accredited tests. Statements of conformity are based on simple acceptance criteria without taking measurement uncertainty into account, unless otherwise requested in writing. You have 60 days from date of issuance of this report to notify us of any material error or omission caused by our negligence or if you require measurement uncertainty; provided, however, that such notice shall be in writing and shall specifically address the issue you wish to raise. A failure to raise such issue within the prescribed time shall constitute your unqualified acceptance of the completeness of this report, the tests conducted and the correctness of the report contents.

NDA, RoHS, REACH and WEEE Compliance

See our Compliance Statement at [NDA, RoHS, REACH and WEEE Compliance Statement | Lantronix](#)

Electrical Safety Warnings

Electrical Safety

IMPORTANT: This equipment must be installed in accordance with safety precautions.

Elektrische Sicherheit

WICHTIG: Für die Installation dieses Gerätes ist die Einhaltung von Sicherheitsvorkehrungen erforderlich.

Elektrisk sikkerhed

VIGTIG: Dette udstyr skal installeres i overensstemmelse med sikkerhedsadvarslerne.

Elektrische veiligheid

BELANGRIJK: Dit apparaat moet in overeenstemming met de veiligheidsvoorschriften worden geïnstalleerd.

Sécurité électrique

IMPORTANT: Cet équipement doit être utilisé conformément aux instructions de sécurité.

Sähköturvallisuus

TÄRKEÄÄ: Tämä laite on asennettava turvaohjeiden mukaisesti.

Sicurezza elettrica

IMPORTANTE: questa apparecchiatura deve essere installata rispettando le norme di sicurezza.

Elektrisk sikkerhet

VIKTIG: Dette utstyret skal installeres i samsvar med sikkerhetsregler.

Segurança eléctrica

IMPORTANTE: Este equipamento tem que ser instalado segundo as medidas de precaução de segurança.

Seguridad eléctrica

IMPORTANTE: La instalación de este equipo deberá llevarse a cabo cumpliendo con las precauciones de seguridad.

Elsäkerhet

OBS! Alla nödvändiga försiktighetsåtgärder måste vidtas när denna utrustning används.

**Lantronix Corporate Headquarters**

48 Discovery, Suite 250
Irvine, CA 92618, USA
Toll Free: 800-526-8766
Phone: 949-453-3990
Fax: 949-453-3995

Technical Support

Online: <https://www.lantronix.com/technical-support/>

Sales Offices

For a current list of our domestic and international sales offices, go to the Lantronix web site at www.lantronix.com/about/contact.