

Secure Remote Access (SRA) Secure Tunnel Solution

A Bidirectional Communication Channel from a Network Operations Center (NOC) to a Remote Site



Install Guide

Intellectual Property

© 2022 Lantronix, Inc. All rights reserved. No part of the contents of this publication may be transmitted or reproduced in any form or by any means without the written permission of Lantronix.

Lantronix is a registered trademark of Lantronix, Inc. in the United States and other countries.

Patented: <https://www.lantronix.com/legal/patents/>; additional patents pending.

Warranty

For details on the Lantronix warranty policy, go to our web site at <http://www.lantronix.com/support/warranty>.

Contacts

Lantronix Corporate Headquarters

7535 Irvine Center Drive
Suite100
Irvine, CA 92618, USA
Toll Free: 800-526-8766
Phone: 949-453-3990
Fax: 949-453-3995

Technical Support

Online: <https://transition.com/support/>

Sales Offices

For a current list of our domestic and international sales offices, please go to www.lantronix.com/about/contact.

Disclaimer

All information contained herein is provided "AS IS." Lantronix undertakes no obligation to update the information in this publication. Lantronix does not make, and specifically disclaims, all warranties of any kind (express, implied or otherwise) regarding title, non-infringement, fitness, quality, accuracy, completeness, usefulness, suitability or performance of the information provided herein. Lantronix shall have no liability whatsoever to any user for any damages, losses and causes of action (whether in contract or in tort or otherwise) in connection with the user's access or usage of any of the information or content contained herein. The information and specifications contained in this document are subject to change without notice.

Revision History

Date	Rev	Notes
6/11/21	A	Initial release at SRA Software Version 1.0.3.
4/7/22	B	Initial Lantronix rebrand.

Contents

Introduction	4
Ordering Information	4
Features / Benefits	4
Specifications	5
For More Information	5
SRA – Secure Remote Access for Configuration and Monitoring	6
Application Overview	6
Application Example	7
Hardware Overview	8
Back Panels	8
Front Panel LEDs	9
RAD LED Descriptions	9
MAP LED Descriptions	9
DB9 Null Modem Cable	9
Unpacking	10
Package Contents	10
Power Supply Information	10
25168 North America Power Supply	11
Network Configuration Guidelines	14
System Requirements	14
MAP Configuration Requirements	14
RAD Configuration Requirements	15
Application Examples	15
Secure Remote Access using Secure Tunnels	15
Secure Remote Access with Port Forwarding	16
Setup	16
Basic Troubleshooting	18
CLI Troubleshooting	18
Device Label and Box Label	18
Record Device and System Information	19
Related Information	19
Regulatory Agency Information	19
Declaration of Conformity	20
Safety Information	21
High Risk Activities Disclaimer	21
Cautions and Warnings	21
Electrical Safety Warnings	23
Recycling / Disposal	23

Introduction

The Lantronix Secure Remote Access (SRA) solution creates a secure tunnel to provide a bidirectional communication channel from a Network Operations Center (NOC) to a Remote Site. The solution generally does not require configuration changes to the Remote Site Firewall.

The Remote Access Device (RAD) is located at a Remote Site and initiates a connection with the Management Access Portal (MAP) located at the NOC or Host Site. Once the tunnel is established, the Network Administrator at the NOC can connect via VPN over the tunnel to devices in the same network as the Remote Access Device, or via Port Forwarding to any device the RAD can address.

SRA provides the capability for a Network Managed Services company or Integrator team to configure and monitor network devices at an end-user customer site with minimal interaction with the remote network. **Note:** When using VPN mode, IP addresses at the Remote Site and NOC or Host Site cannot overlap (i.e., must be on different sub-networks).

Ordering Information

SKU	Description
SRA-MAP-01-xx	Secure Management Access Portal. An SRA-MAP-01 can support multiple SRA-RAD-01
SRA-RAD-01-xx	Secure Remote Access Device
Power Supplies	Power Supplies (country specific) are included when ordering SRA-MAP-01 and SRA-RAD-01 with the -xx suffix: <ul style="list-style-type: none"> • 25168 North America Power Supply; order SRA-MAP-01-NA and SRA-RAD-01-NA • 25183 United Kingdom Power Supply; order SRA-MAP-01-UK and SRA-RAD-01-UK • 25184 European Power Supply; order SRA-MAP-01-EU and SRA-RAD-01-EU
CABLE-SRA-NMC	Cable, USB to DB9F Serial Null Modem (optional accessory sold separately)

Features / Benefits

Feature	Benefit
Secure Remote Access	<ul style="list-style-type: none"> - Provides secure access to remote sites utilizing encrypted tunnels - Connection initiated from within customer network (In-to-Out) for security - Reduces the need for truck rolls to remote sites - Allows for more intelligent truck rolls when necessary - Allows for proactive maintenance for upgrades, backups and restores - Real-time health monitoring - Provides the ability to monitor troubled sites in real-time - Offers the ability to sell additional services - Improves customer satisfaction
Access to Remote Sites	<ul style="list-style-type: none"> - A secure tunnel is initiated from In-to-Out - Secure encrypted tunnel protects the privacy and integrity of the exchanged data while in transit - Bidirectional encryption protects against eavesdropping and tampering - OpenVPN utilized for whole site access - Port forwarding utilized for device specific access

Specifications

Access Method	WebSocket tunnel over port 443 (or user defined)
Ports	10/100/1000Base-T RJ-45 ports (two on RAD, four on MAP) Two USB Ports One DB9 RS232 Console Port
Status LEDs	RAD: PWR: Power, LED 2: Not used, LED 3: Not used MAP: PWR: Power, LED 2: Not used, LED 3: Not used
Dimensions	Width: 6.618" [168.1 mm] x Height: 1.102" [28 mm] x Depth: 6.169" [156.7 mm]
Power	Compact external AC adapter; max Power: 23 Watts
Power Input	90 to 264 VAC, 47-50 / 60-63Hz
Power Output	12VDC, with over-current protection
Environment	Operating Temp: 0°C to +40°C
Weight	RAD: 0.95 lb [0.43 kg] MAP: 1.0 lb [0.45 kg]
Certifications	Safety: IEC/EN 60950-1, UL 60950-1, CSA C22.2 No. 60950-1-03, GB4943, EN60335 Certifications: CB, GS, CE, TUV, UL, CCC, FCC, PSE, KC, C-TICK Emission: Radiation Test & Conduction Test: EN 55022/ FCC Part 15, Harmonic Test: EN 61000-3-2 , Flicker Test: EN 61000-3-3 Immunity: ESD Test: EN 61000-4-2, RS Test: EN 61000-4-3, EFT Test: EN 61000-4-4, Surge Test: EN 61000-4-5, CS Test: EN 61000-4-6, DIP Test: EN 61000-4-11
Warranty	5 Years

For More Information

For Lantronix Drivers, Firmware, etc. go to the [Product Support](#) webpage (logon required).

For Lantronix Manuals, Brochures, Data Sheets, etc. go to the [Support Library](#) (no logon required).

Related Manuals include:

- Secure Remote Access (SRA) Quick Start Guide, 33837
- Secure Remote Access (SRA) Web User Guide, 33795
- Secure Remote Access (SRA) CLI Reference, 33839
- Release Notes (version specific)



SRA – Secure Remote Access for Configuration and Monitoring

SRA provides the capability for the Integrator team to configure and monitor switches at an end user customer site with minimal interaction with the remote network.

- Uses a WebSocket tunnel over port 443 to provide a secure bidirectional communication channel.
- Does not require configuration changes to the Firewall as port 443 is open for https traffic.
- WebSocket Client at End Customer Site can either:
 - Initiate the connection to the WebSocket server at the host and keep the connection up, or:
 - Poll the WebSocket Server on the Appliance at the Integrator to see if it needs to communicate with the End customer network, then establish the WebSocket tunnel for as long as it is needed, then close the connection.
- Once the WebSocket tunnel is established, the Network Administrator can log into the VPN server on the appliance at the End customer site and manage the devices in the same subnet as the appliance.
- VPN connection is made over the WebSocket, so it does not require configuration changes to the firewall.
- Appliance at Customer site can be run on a small custom device/custom switch.

Per IETF [RFC 6455](https://www.rfc-editor.org/rfc/rfc6455): the WebSocket Protocol enables two-way communication between a client running untrusted code in a controlled environment to a remote host that has opted-in to communications from that code. The security model used for this is the origin-based security model commonly used by web browsers.

Application Overview

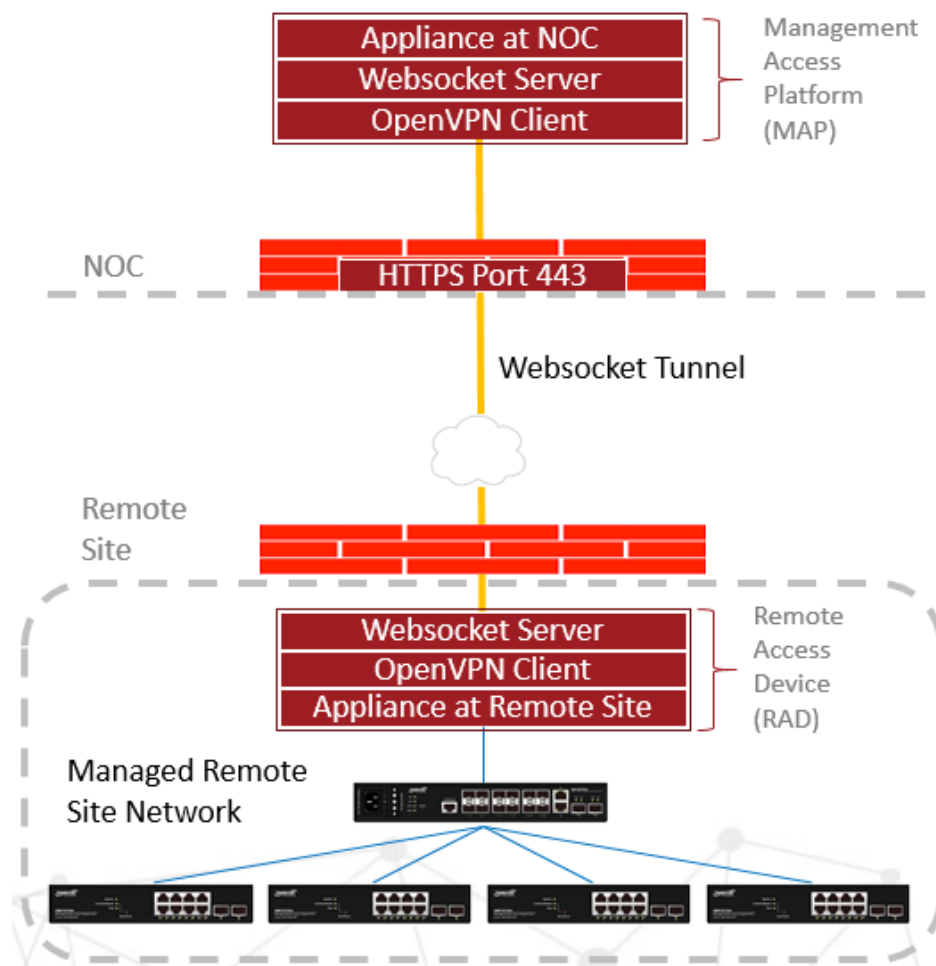

Application Example

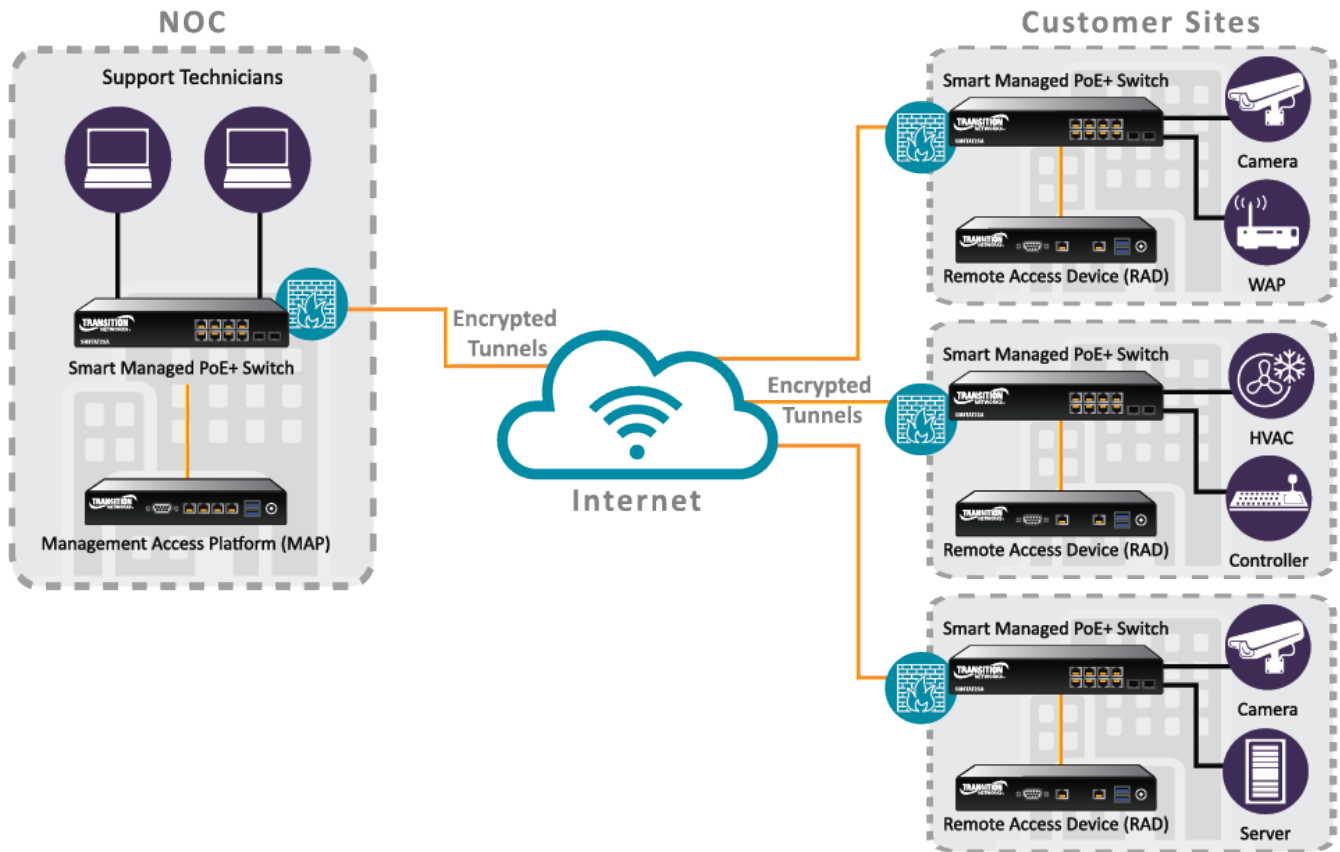

Figure 1. Application Example

Hardware Overview

Back Panels

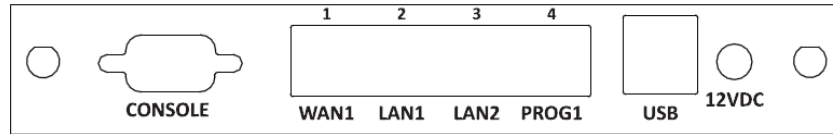

Figure 2. SRA-MAP Back Panel

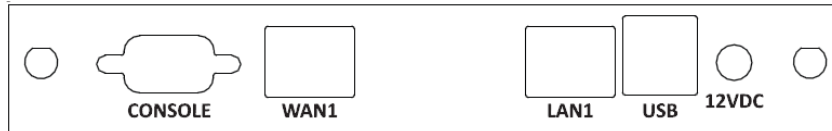

Figure 3. SRA-RAD Back Panel

CONSOLE: DB-9 connector for Command Line Interface (CLI) operation.

WAN1: RJ-45 connector for IP connectivity.

LAN1: : RJ-45 connector for IP connectivity.

LAN2: : RJ-45 connector; currently not used (SRA-MAP only).

PROG1: RJ-45 connector; currently not used (SRA-MAP only).

USB: USB connector for firmware upgrades.

12VDC: Power connection to DC power supply.

Front Panel LEDs

The front panel has three green LEDs (labeled PWR, 1 and 2) and a RESET button (not used).



Figure 4. Front Panel (RAD and MAP)

RAD LED Descriptions

PWR: Power; continuously lit means RAD power is good.

LED 1: currently not used; always off.

LED 2: currently not used; always off.

MAP LED Descriptions

PWR: Power; continuously lit means MAP power is good.

LED 1: currently not used; always off.

LED 2: currently not used; always off.

DB9 Null Modem Cable

When connecting to the serial port on SRA units, use a null modem cable with a female DB9 connector, such as the CABLE-SRA-NMC available through Lantronix.

Unpacking

The SRA-MAP, SRA-RAD, and power supply are packaged separately as described below.



Package Contents

Verify you have received the following items. Contact your sales representative if any item is missing or damaged. Please save the packaging for possible future use.

- One Secure Remote Access Device (SRA-RAD-01) **or** One Secure Management Access Portal (SRA-MAP-01)
- One Documentation postcard
- One Power Supply per device
- One printed Quick Start Guide
- Bag with screws, rubber plugs, and rubber feet
- One CABLE-SRA-NMC (USB to DB9F Serial Null Modem Cable) (optional accessory)

SRA-MAP-01 BOM:

Part #	Qty	Description
SRA-MAP-01	1	Secure Remote Access MAP
33504	1	Product Support Postcard
33837	1	Manual, Secure Remote Access Quick Start Guide (printed manual)
33838	0	Manual, Secure Remote Access Install Guide (online manual)
33839	0	Manual, Secure Remote Access CLI Reference (online manual)
33795	0	Manual, Secure Remote Access Web User Guide (online manual)
----	4	Rubber Feet

SRA-RAD-01 BOM:

Part #	Qty	Description
SRA-RAD-01	1	Secure Remote Access RAD
33504	1	Product Support Postcard
33837	1	Manual, Secure Remote Access Quick Start Guide (printed manual)
33838	0	Manual, Secure Remote Access Install Guide (online manual)
33839	0	Manual, Secure Remote Access CLI Reference (online manual)
33795	0	Manual, Secure Remote Access Web User Guide (online manual)
----	4	Rubber Feet

Power Supply Information

The available power supplies for SRA include:

- 25168 North America Power Supply
- 25183 UK Power Supply
- 25184 Europe Power Supply

The 25168 power supply for North America, 25183 for UK, and 25184 for Europe are the same except for the connector and housing. Compliance labeling varies by market.

25168 North America Power Supply

The 25168 is an AC adapter with US plug; 12VDC@2.0A with Universal Input and 2.5mm Plug. This compact AC adapter saves space on power strips. Input voltage 100-240 V AC, 50/60 Hz. Output voltage 12 V DC, maximum current 2A. High efficiency, DOE level VI compliant. Jack inner diameter 2.5 mm, outer diameter 5.5 mm, center positive.

Compliance: UL (US / Canada) certified. DOE level VI energy efficiency. RoHS compliant.

Note: boards have very low ESR input capacitors. To avoid arcing on the DC jack, plug in the DC jack first, then plug the AC adapter into mains.



25168 Specifications

- Reliability level of 100K hours MTBF @ 25° C (rated input voltage and using the BELLCORE SR-332 method).
- DC output voltage must be Safe Extra Low Voltage (SELV) & Limited Power as defined by IEC60950-1.
- Maximum room ambient temperature (Tmra), as mentioned in IEC60950-1 clause 1.4.12 is 40°C.
- Cooling: natural convection.

INPUT REQUIREMENTS

Input Conditions : The Supply shall operate over the voltage ranges as follows:

- Rated input voltage 100-240Vac
- Operating range 90-264Vac
- Rated input frequency 50/60Hz +/- 3Hz
- Rated input current 0.6A max.
- Maximum input power 29.31W
- Input current (no-loading) ≤25mA
- Power consumption (no-loading) 0.1W max.
- Primary current protection: An adequate internal fuse on the AC input line is provided.
- Configuration: 2 Conductor

AC Inrush Current : No damage will occur and the input fuse will not blow with nominal input voltage full load 25°C; cold start Inrush Current will be 60A at 230V Full load.

OUTPUT REQUIREMENTS

- Nominal DC output voltage +12.0V
- Minimum load current 0.0A
- Rating load current 2.0A
- Peak load current /
- Rating output power 24W
- Line regulation: Less than ±5% while measuring at rated load and +/-10% of input voltage changing.
- Load regulation: The load regulation for +12V is less than +/-5%, at measured output load from 10% to 100% rated load.

Protection function

- Over-voltage protection: The output voltage shall be clamped by internal protection.
- Short-circuit protection: The adapter will not be damaged by short the DC output to Ground. The adapter shall resume normal operation when a short circuited fault condition is removed.
- Over current protection: The power supply will be protected when output power at 110-200% of all rated DC output.

Dimensions: 89x33x44.5 mm

25168 REGULATORY COMPLIANCE

EMC Specifications

Radiated and Conducted Emissions: The power supply complies to FCC part 15: Class B for radiated and conducted emissions. EN55032, Class B for radiated and conducted emissions. GB9254, GB17625.1.

Immunity

Electrostatic Discharge Immunity:

EN 55024, EN 61000-4-2

Air Discharge: $\pm 15\text{kV}$

Contact Discharge: $\pm 8\text{kV}$

Performance Criteria A

Radiated Field Immunity

EN 55024, EN 61000-4-3

Frequency Range: 80-1000MHz

Field Strength: 3 V/m with 80% amplitude modulation of 1 kHz

Performance Criteria A

Radio-frequency electromagnetic field susceptibility test, RS 80-1000MHz, 3V/m, 80%AM(1kHz).

Fast Transient Immunity

EN 55024, EN 61000-4-4

- Power line: 1kV

- Signal line: 0.5kV

- Performance Criteria B

Surge Immunity

EN 55024, EN 61000-4-5

- 1.2/50 usec Open Circuit voltage

- 8/20 usec Short Circuit current

- Power line: 1kV

- Line to Earth: 2kV

Lightning Surge Voltage applied in differential and common mode to AC input lines and cross primary ac input and secondary GND.

Safety Requirements and Certification

Regulatory Standards: UL 60950-1, CUL CSA C22.2 NO.60950-1

Additional Safety Requirements: Dielectric Withstand Voltage, Primary(input AC short)-to-Secondary(output DC short): 3000Vac, 5m A, 1 minute.

Insulation Resistance, Input to output: 20M Ω (MIN.) at 500VDC.

Reinforced insulation system, Primary-to-Ground and Primary-to-Secondary.

The leakage current will not exceed 0.25mA.

ENVIRONMENTAL REQUIREMENTS

Temperature: Operating: 0°C to +40°C; Non-Operating: -25°C to +80°C.

Humidity: Operating: 10%~90% (Non Condensing). Non-Operating: 10%~90% (Non Condensing)

25168 Dimensions Drawing

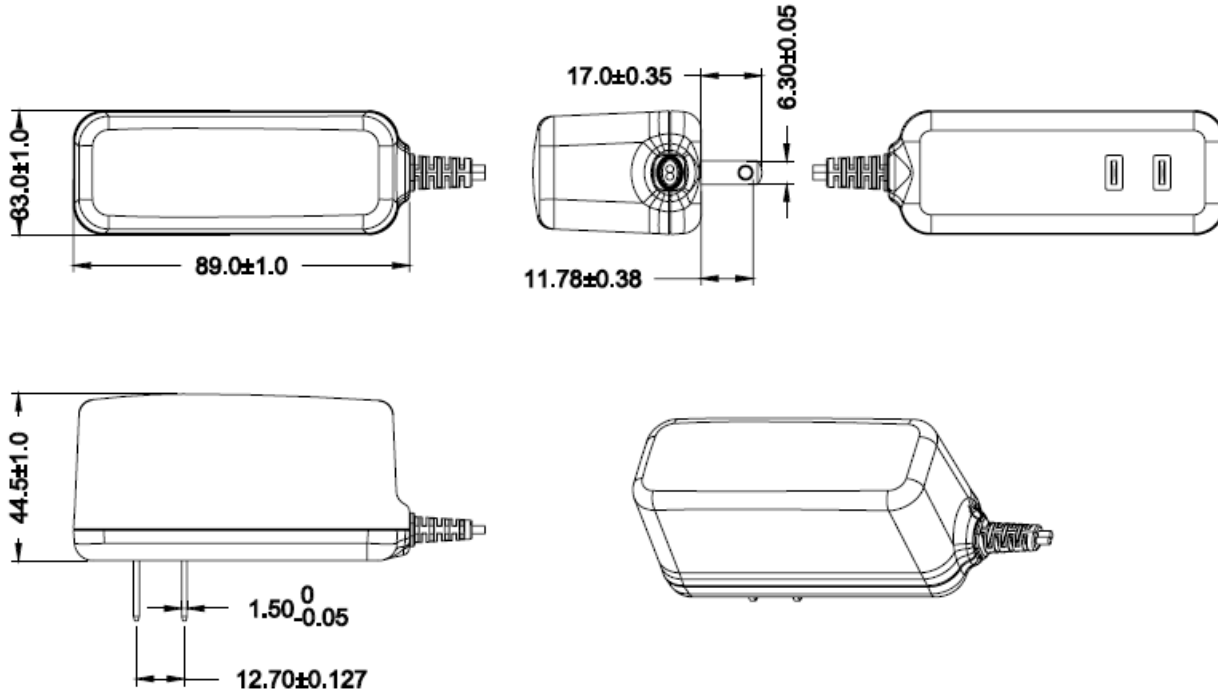

25168 Output Plug & DC Cord Dimensions (Unit: mm)

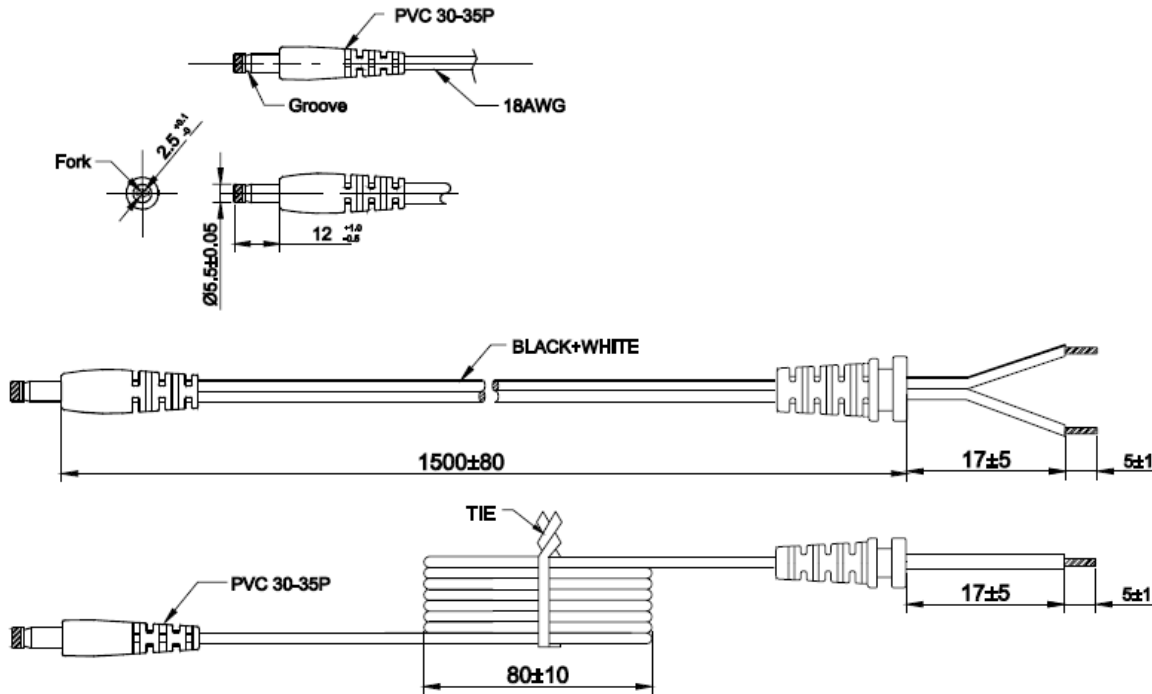

NOTE: (unit:mm)

1). WIRE TYPE: VW-1 80°C 300V L=1500mm 2468 18AWG 2C BLACK+WHITE

BLACK and WHITE—Positive BLACK—Negative

2). THE POLARITY: ⊖ ⊕

3). PAHS+REACH+RoHS

Network Configuration Guidelines

System Requirements

- SRA devices must have one interface with a gateway that allows Internet access.
- You must have OpenVPN (Windows) client installed when using the VPN solution for the remote site; not necessary for Port Forwarding. Note that some versions of Windows allow only one active VPN client connection at a time.
- When using VPN mode, the IP subnet for the LAN1 interface on the MAP cannot overlap with the IP subnet being forwarded by any of its RADs.
- External IP (Internet facing IP) address with available port 443.
- IP address(es) for the MAP and RAD.
- Network setup details of remote sites.
- A null modem cable with a female DB9 connector, such as the CABLE-SRA-NMC available through Lantronix if using CLI to program units.

MAP Configuration Requirements

"MAP users" refers to users at headquarters/Network Operations Center (NOC) who are using SRA to access devices at remote sites. MAP requirements:

- The MAP requires Internet accessible port 443 available:
 - this will likely be forwarded from the firewall and it doesn't matter which interface is given port 443;
 - the interface receiving 443 should have a gateway providing Internet access.
- MAP users will access the Web UI via the LAN1 interface.
- The MAP must have Internet access to communicate with the RADs; to accomplish this one interface must have a gateway assigned statically or via DHCP.
- If both interfaces are in use, make sure only one has a gateway assigned.

With the requirements in mind, the simplest configuration would be to disable WAN1, statically assign an IP address with gateway on LAN1 and forward port 443 from an external IP Address on your firewall to this IP address.

DHCP can be used on LAN1 but it is expected that the IP Address does not change; be sure to configure your DHCP server to hand out a specific IP address to the LAN1 port.

If the MAP is to be on separate (tiered) networks, the WAN1 interface can be configured with DHCP, configuring the DHCP server to hand out a specific IP address to the WAN1 interface, or with a static IP Address and gateway while the LAN1 interface is given an IP address on the separate MAP users network. In this scenario, port 443 would be forwarded from the firewall to WAN1.

Make sure that if the MAP is behind a firewall that port 443 from the External IP Address is forwarded to one of the interfaces on the MAP.

On the internal network, users are expected to access the MAP via the LAN1 interface. The port forwards and VPN configuration files all use the IP Address of the LAN1 interface. It is ok to disable the WAN1 interface and use just the LAN1 interface, forwarding 443 from the External IP Address to LAN1's IP Address. **Note:** The MAP is not intended to be directly connected to the internet via its WAN port, but to sit behind a firewall / router which forwards in-bound port 443 (assuming default port config) from the internet to the MAP, and that the MAP's "Internet facing IP" is not the MAP's WAN IP, but the router's WAN IP which can be reached via the internet. The RADs will phone home to this Internet IP, and the port 443 traffic must be forwarded to the MAP via specific router / firewall config.

RAD Configuration Requirements

Requirements:

- The RAD requires Internet access
- The RAD requires access to devices/network that MAP users want to manage

Most RAD networks are a single (flat) network with DHCP servers available. For Port Forwarding, the simplest configuration is the default: WAN1 connected to this flat network, LAN1 not used. The RAD will use WAN1 both for internet access and to connect to the devices the MAP users must manage.

For VPN, WAN1 would be connected to the network with Internet access, likely using DHCP (the default setting on WAN1) or configured with an IP Address and gateway. For VPN, LAN1 would be configured for the separate network that is to be accessed by the MAP users.

Note: The RAD ID can include spaces and disconnected RADs can be removed (RED status). A RAD ID can be modified while connected to a MAP. On the MAP, duplicate RAD IDs can exist; please avoid this if possible. If multiple RAD's are created with the same RAD ID, the matching ones must be disconnected and then all can be deleted from the MAP. While disconnected, the RAD IDs should be changed so they are all unique.

Application Examples

Secure Remote Access using Secure Tunnels

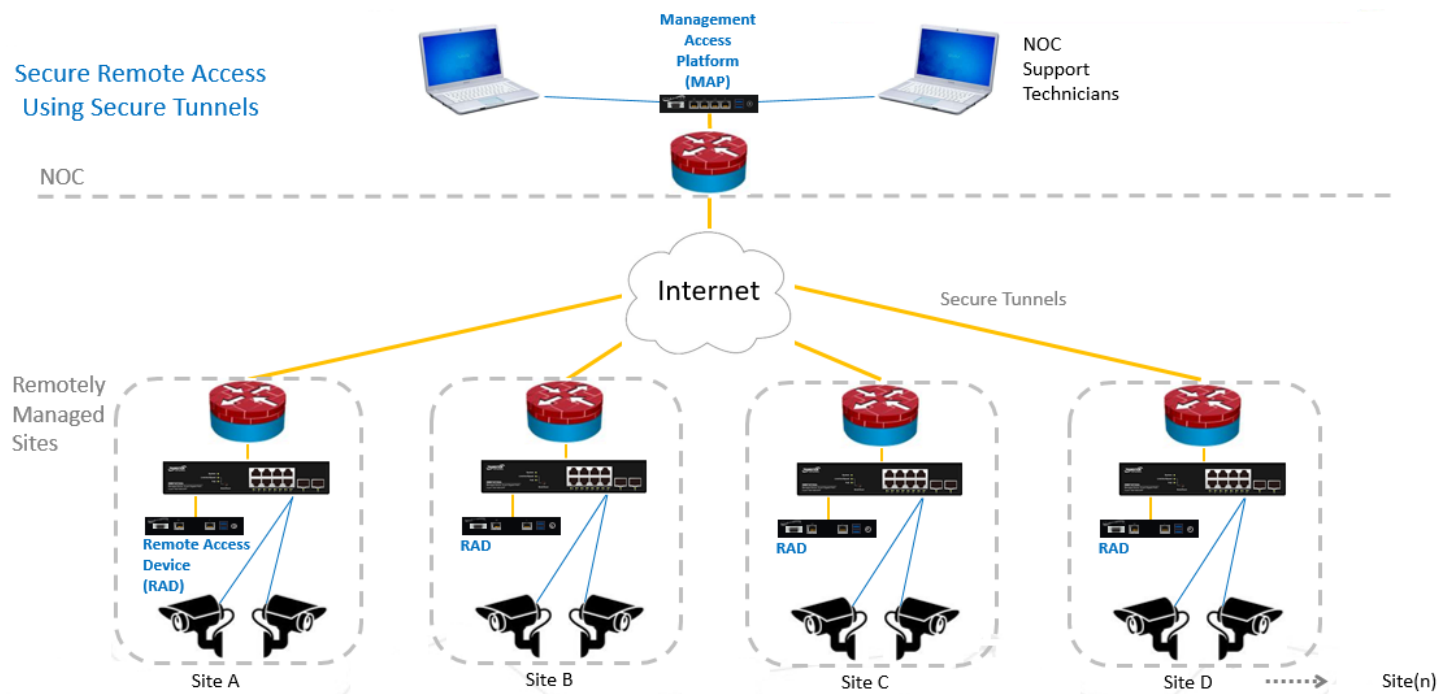

Secure Remote Access with Port Forwarding

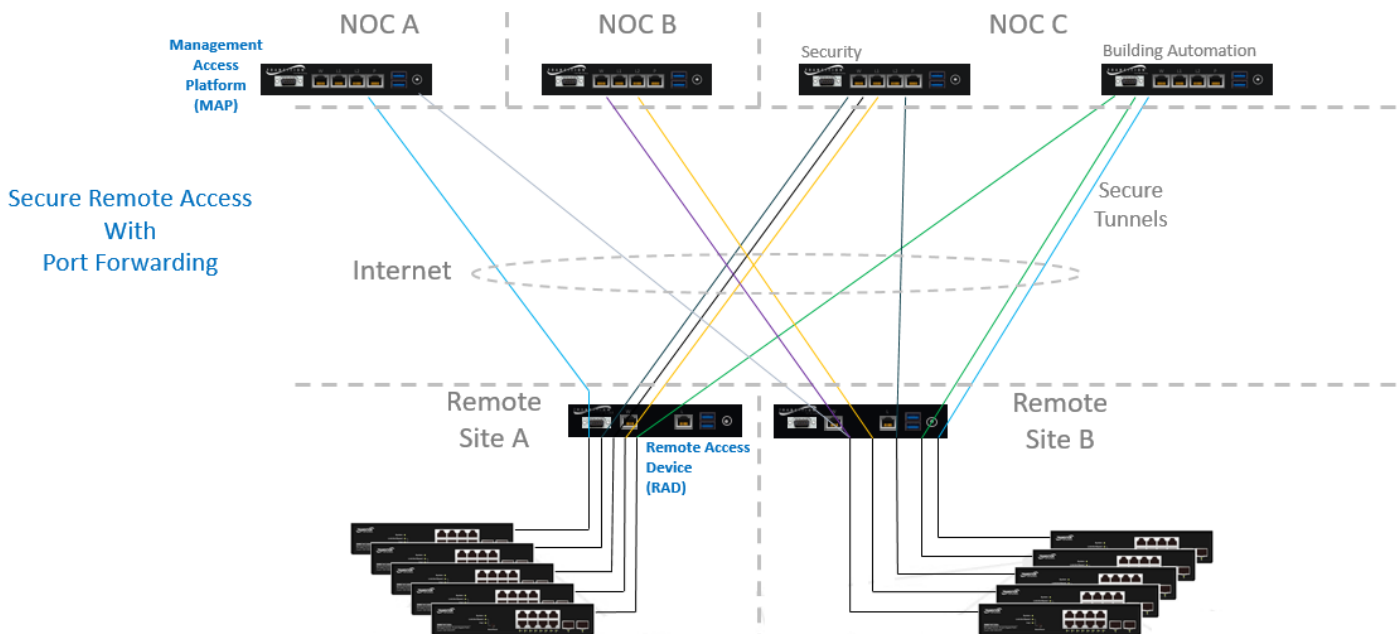

Setup

Caution: To avoid arcing on the DC jack, plug in the DC jack first, then plug the AC adapter into mains.
To operate the Secure Remote Access solution:

MAP Setup

1. Connect Cat5/6 cable from PC to LAN1 port on RAD.
2. Open web browser and go to 192.168.1.10.
3. Login using default username/password: admin/admin.
4. Go to MAP Configuration Tab and fill in MAP ID, Internet Facing IP, and Ext Port. Click Apply.
5. Go to Network Configuration tab.
6. Fill in network configuration information. Click Apply.
7. Change PC IP address to work with new MAP IP address.
8. Log back into the MAP.
9. Go to Network Info tab and verify network information is correct.

RAD Setup

1. Connect Cat5/6 cable from PC to LAN1 port on RAD.
2. Open web browser and go to 192.168.1.10.
3. Login using default username/password: admin/admin.
4. Go to Network Configuration tab.
5. Fill in network configuration information. Click Apply.
6. Change PC IP address to work with new RAD IP address.
7. Log back into the RAD.
8. Go to Network Info tab and verify network information is correct.
9. Go to Configurations tab and assign a Site ID and select Update ID.
10. Go to Configurations tab and select Configure VPN.
11. Fill in Mgmt IP, Client IP, and Client count. (Note: Leave VPN Mode as "Disabled".)
12. Select Save VPN Config.
13. Go to Configurations tab and select Add MAP.
14. Fill in Internet facing IP, External Port, set Mode to VPN, set Status to Enabled in the order shown below.
15. Select Save MAP Config. ***You will now lose connection to the RAD unit.***
16. Connect WAN1 and LAN1 into 192.168.2.0/24 network at the remote site.

Caution: After app cfg is sent to reconfigure the RAD, edit the config file. Run the show rad command to verify the configuration via the console port.

Note: The install process can be killed from the CLI with ctrl-c.

Use Serial port settings: Speed=115200, Parity=None, Data bits=8, Stop bits=1, HW Flow Control=No, and SW Flow Control=No as console port settings for Command Line Interface (CLI) operation. Do not use the serial cable to update the firmware. When connecting to the serial port on SRA units, use a null modem cable with a female DB9 connector, such as the CABLE-SRA-NMC available through Lantronix.

Basic Troubleshooting

1. Verify Ordering Information on page 4.
2. Verify Features on page 4.
3. Verify [Specs](#) on page 5.
4. Verify System Requirements on page 14.
5. Review Setup on page 16.
6. Check Front Panel LEDs on page 9.
7. See Record Device and System Information on page 19.
8. Contact Lantronix Technical Support.

CLI Troubleshooting

The most common mistake is not using a null-modem cable: if you have a multimeter, check that the pins 2 and 3 are crossed. Do NOT use gender changers!

Use Serial port settings: Speed=115200, Parity=None, Data bits=8, Stop bits=1, HW Flow Control=No, and SW Flow Control=No as console port settings for Command Line Interface (CLI) operation. Do not use the serial cable to update the firmware. When connecting to the serial port on SRA units, use a null modem cable with a female DB9 connector, such as the CABLE-SRA-NMC available through Lantronix.

The recommended terminal emulation program for any platform is PuTTY. See <http://www.chiark.greenend.org.uk/~sgtatham/putty/download.html>

Device Label and Box Label

The device label and box label contain information that Technical Support will need to assist in troubleshooting.

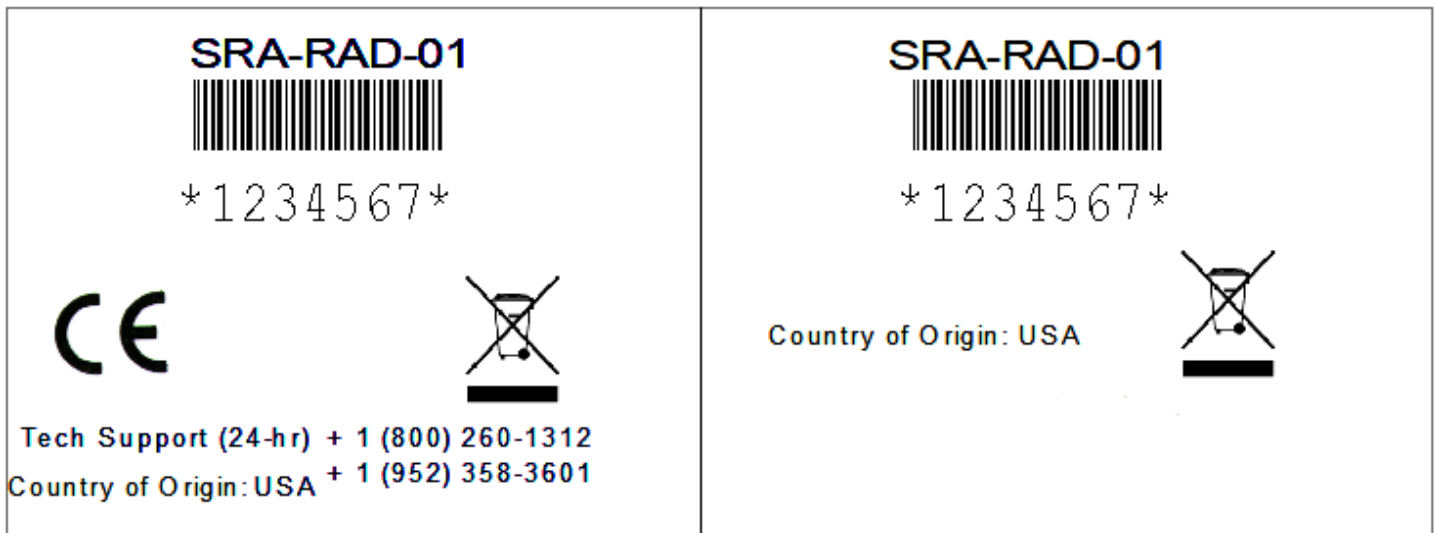

Device Label

Box Label

Record Device and System Information

After performing the Troubleshooting steps above, and before calling Technical Support, record:

MAP Configuration:

MAP ID: _____ Internet facing IP: _____

System Information:

Serial #: _____ Wan1 MAC Address: _____

Version: _____ Lan1 MAC Address: _____

Wan1 Configuration: _____ Lan1 Configuration: _____

Network Information:

IP Information: _____ Route Information: _____

DNS Info: _____

Current Alarms: _____

Alarms History: _____

Error Messages: _____

Related Information

Regulatory Agency Information

This product has been tested and found to comply with the limits for a Class B digital device pursuant to Part 15 of the FCC Rules. These limits are designed to provide reasonable protection against harmful interference when the equipment is operated in a commercial environment. This product generates, uses, and can radiate radio frequency energy and, if not installed and used in accordance with the manufacturer's instruction manual, may cause harmful interference with radio communications. Operation of this product in a residential area is likely to cause harmful interference, in which case you will be required to correct the interference at your own expense.

This device complies with Part 15 of the FCC Rules. Operation is subject to the following two conditions:

- 1) This device may not cause harmful interference.
- 2) This device must accept any interference received, including interference that may cause undesired operation.

CE MARK DECLARATION OF CONFORMANCE FOR EMI AND SAFETY (EEC): This equipment has been tested and found to comply with the protection requirements of European Emission Standard EN55022/EN61000-3 and the Generic European Immunity Standard EN55024.

Declaration of Conformity

<h1 style="margin: 0;">Declaration of Conformity</h1>			
<i>Transition Networks, Inc.</i> <small>Manufacturer's Name</small>			
<u>10900 Red Circle Drive, Minnetonka, Minnesota 55343 U.S.A.</u> <small>Manufacturer's Address</small>			
Declares that the products:			
SRA-MAP-01 Secure Management Access Portal SRA-RAD-01 Secure Remote Access Device			
Conforms to the following Product Regulations:			
FCC Part 15 Class B, EN 55032:2012, EN 55024:2010 Directive 2014/30/EU Low-Voltage Directive 2014/35/EU IEC /EN 60950-1:2006+A2:2013 2011/65/EU EN 50581:2012			
With the technical construction on file at the above address, this product carries the CE Mark			
I, the undersigned, hereby declare that the equipment specified above conforms to the above Directive(s) and Standards(s).			
<u>Minnetonka, Minnesota</u> <small>Place</small>	<u>March 2, 2021</u> <small>Date</small>	 <small>Signature</small>	<small>28141B</small>
	<u>Stephen Anderson</u> <small>Full Name</small>	<u>Vice President of Engineering</u> <small>Position</small>	

SRA-MAP-01 and SRA-RAD-01 conform to the following specifications:
FCC Part 15, Subpart B, Unintentional Radiators

Supplementary Information: The device complies with part 15 of the FCC Rules. Operation is subject to the following two conditions: (1) This device may not cause harmful interference, and (2) this device must accept any interference received, including interference that may cause undesired operation.

System Board (SRA-RAD-01)

EMC:

EN 55032:2015 / AC:2016 Class B

EN 61000-3-2:2014

EN 61000-3-3:2013

EN 55024:2010/A1:2015

ROHS: EN 50581:2012

This product herewith complies with the requirements of the EMC directive 2014 / 30/EU, and the RoHS directive 2011 / 65 / EU and carries the CE marking accordingly.

System Board (SRA-MAP-01)

EN 55032:2012/AC:2013, Class B

EN 61000-3-2:2014

EN 61000-3-3:2013

EN 55024:2010/A1:2015

AC Adapter

EN 55032:2015

EN 55020:2007 + A11:2011

EN 55024:2010 + A1:2015

EN 61000-3-2:2014

EN 61000-3-3:2013

mSATA SSD

EN55022 / CISPR 22 / AS/NZS CISPR 22

Class B

EN55024 / CISPR 24 / IMMUNITY

EN61000-3-2 / EN 61000-3-3

Safety Information

Do not open the chassis - No field serviceable parts.

High Risk Activities Disclaimer

Components, units, or third-party products used in the product described herein are NOT fault-tolerant and are NOT designed, manufactured, or intended for use as on-line control equipment in the following hazardous environments requiring fail-safe controls: the operation of Nuclear Facilities, Aircraft Navigation or Aircraft Communication Systems, Air Traffic Control, Life Support, or Weapons Systems ("High Risk Activities"). Lantronix and its supplier(s) specifically disclaim any expressed or implied warranty of fitness for such High Risk Activities.

Cautions and Warnings

Cautions indicate that there is the possibility of poor equipment performance or potential damage to the equipment. **Warnings** indicate that there is the possibility of injury to person.

Cautions and Warnings appear here and may appear throughout this manual where appropriate. Failure to read and understand the information identified by this symbol could result in poor equipment performance, damage to the equipment, or injury to persons.

Caution : While installing or servicing the power module, wear a grounding device and observe all electrostatic discharge precautions. Failure to observe this caution could result in damage to, or failure of the power module.

Warning: Do not connect the power module to an external power source before installing it into the chassis. Failure to observe this warning could result in an electrical shock, even death.

WARNING: The power module has a provision for grounding. Equipment grounding is vital to ensure safe operation. The installer must ensure that the power module is properly grounded during and after installation. Failure to observe this warning could result in an electric shock, even death.

WARNING: A readily accessible, suitable National Electrical Code (NEC) or local electrical code approved disconnect device and branch-circuit protector must be part of the building's installed wiring to accommodate permanently connected equipment. Failure to observe this warning could result in an electric shock, even death.

WARNING: Turn the external power source OFF and ensure that the power module is disconnected from the external power source before performing any maintenance. Failure to observe this warning could result in an electrical shock, even death.

WARNING: Ensure that the disconnect device for the external power source is OPEN (*turned OFF*) before disconnecting or connecting the power leads to the power module. Failure to observe this warning could result in an electric shock, even death.

Warning: Because invisible radiation might be emitted from the aperture of the port when no fiber cable is connected, avoid exposure to radiation and do not stare into open apertures.

General Laser Safety Guidelines: When working around ports that support optical transceivers, observe the following safety guidelines to prevent eye injury:

- Do not look into unterminated ports or at fibers that connect to unknown sources.
- Do not examine unterminated optical ports with optical instruments.
- Avoid direct exposure to the beam.

Electrical Safety Warnings

Electrical Safety

IMPORTANT: This equipment must be installed in accordance with safety precautions.

Elektrische Sicherheit

WICHTIG: Für die Installation dieses Gerätes ist die Einhaltung von Sicherheitsvorkehrungen erforderlich.

Elektrisk sikkerhet

VIGTIGT: Dette udstyr skal installeres i overensstemmelse med sikkerhedsadvarslerne.

Elektrische veiligheid

BELANGRIJK: Dit apparaat moet in overeenstemming met de veiligheidsvoorschriften worden geïnstalleerd.

Sécurité électrique

IMPORTANT: Cet équipement doit être utilisé conformément aux instructions de sécurité.

Sähköturvallisuus

TÄRKEÄÄ: Tämä laite on asennettava turvaohjeiden mukaisesti.

Sicurezza elettrica

IMPORTANTE: questa apparecchiatura deve essere installata rispettando le norme di sicurezza.

Elektrisk sikkerhet

VIKTIG: Dette utstyret skal installeres i samsvar med sikkerhetsregler.

Segurança eléctrica

IMPORTANTE: Este equipamento tem que ser instalado segundo as medidas de precaução de segurança.

Seguridad eléctrica

IMPORTANTE: La instalación de este equipo deberá llevarse a cabo cumpliendo con las precauciones de seguridad.

Elsäkerhet

OBS! Alla nödvändiga försiktighetsåtgärder måste vidtas när denna utrustning används.

Recycling / Disposal



Do not discard electronic products in household trash! All waste electronics equipment should be recycled according to local regulations.

Information for the recycler: Remove the LR44 alkaline battery on the PC Board for separate recycling. Enclosures are made of aluminum.

**Lantronix Corporate Headquarters**

7535 Irvine Center Drive
Suite100
Irvine, CA 92618, USA
Toll Free: 800-526-8766
Phone: 949-453-3990
Fax: 949-453-3995

Technical Support

Online: <http://www.transition.com/support>.

Sales Offices

For a current list of our domestic and international sales offices, go to the Lantronix web site at www.lantronix.com/about/contact.