

TN-SFP-xx25G-xR-S Series
Cisco Compatible 10G/25GBase SFP28 Modules
10G/25GBase-X, SFP28 With DMI (LC)

User Guide

Intellectual Property

© 2022 Lantronix, Inc. All rights reserved. No part of the contents of this publication may be transmitted or reproduced in any form or by any means without the written permission of Lantronix.

Lantronix is a registered trademark of Lantronix, Inc. in the United States and other countries.

All other trademarks and trade names are the property of their respective holders.

Patented: <https://www.lantronix.com/legal/patents/>; additional patents pending.

Warranty

For details on the Lantronix warranty policy, please go to our web site at <http://www.lantronix.com/support/warranty>.

Contacts

Lantronix Corporate Headquarters

7535 Irvine Center Drive
Suite100
Irvine, CA 92618, USA
Toll Free: 800-526-8766
Phone: 949-453-3990
Fax: 949-453-3995

Technical Support

Phone: +1.952.358.3601 or 1.800.260.1312
Email: techsupport@transition.com

Sales Offices

For a current list of our domestic and international sales offices, go to the Lantronix web site at www.lantronix.com/about/contact.

Disclaimer

All information contained herein is provided "AS IS." Lantronix undertakes no obligation to update the information in this publication. Lantronix does not make, and specifically disclaims, all warranties of any kind (express, implied or otherwise) regarding title, non-infringement, fitness, quality, accuracy, completeness, usefulness, suitability or performance of the information provided herein. Lantronix shall have no liability whatsoever to any user for any damages, losses and causes of action (whether in contract or in tort or otherwise) in connection with the user's access or usage of any of the information or content contained herein. The information and specifications contained in this document are subject to change without notice.

Revision History

Date	Rev	Notes
3/25/20	A	Initial release.
1/15/21	B	Add TN-SFP-25G-ER, TN-SFP-25G-BX40U-I, and TN-SFP-25G-BX40D-I. Update SFP reported information.
2/8/22	C	Initial Lantronix re-brand

Table of Contents

Product Description	4
Ordering Information.....	4
Optical Specifications	5
Specifications and Standards	5
Applications	6
Safety Instructions	6
SFP Unpacking.....	7
SFP Installation.....	7
Cautions	7
Installing an SFP Module	7
Fiber Cable Physical Characteristics	8
Connecting Fiber Cables.....	8
Removing an SFP Module	9
DDMI (Digital Diagnostics Monitoring Interface)	10
SFP Information and SFP Detail Info	11
SFP Information	11
SFP Detail Info	12
For More Information	13
Compliance Information.....	14

Product Description

The Lantronix TN-SFP-xx25G-xR-S Series 25G SFP28 transceiver modules are designed to install in any SFP28 port allowing for 25G/10GBase-X interfaces to the network via the SFP28 connector. The TN-SFP-xx25G-xR-S transceivers are Cisco Compliant and are designed for bi-directional serial-optical data communication such as 25G Ethernet at speeds up to 26.5 Gbps.

Lantronix SFP28 modules fully comply with the Multi-Sourcing Agreement (MSA). This compliance allows our SFP28 modules to be used in all other MSA compliant [SFP28](#) platforms. In addition, Lantronix SFP28 modules are also Compliant with all Cisco SFP28 based routers and switches, as well as Cisco's IOS software. Lantronix SFP28 modules are not Cisco OEM brand modules.

These SFPs are intended for 25G Ethernet and eCPRI for 5G Fronthaul/Backhaul applications. The eCPRI Interface Specification for the Common Public Radio Interface is an industry cooperation aimed at defining publicly available specifications for the key internal interface of radio base stations, such as eCPRI connecting the eCPRI Radio Equipment Control (eREC) and the eCPRI Radio Equipment (eRE) via a "fronthaul transport network". See the latest eCPRI specification at http://www.cpri.info/downloads/eCPRI_v_1_1_2018_01_10.pdf.

RRH (Remote Radio Head) are distributed on the towers every few miles in cities and suburban areas. These RRHs must be connected to baseband units sitting at centralized locations. The connection between the RRUs and the base station is often called "fronthaul." While 4G (LTE) uses CPRI (Common Public Radio Interface) as the fronthaul connection, eCPRI (enhanced CPRI) is becoming an important technology for 5G and Open RAN. The eCPRI specification is intended to enable efficient and flexible radio data transmission via a packet based fronthaul transport network such as Ethernet or IP.

Ordering Information

SKU	Description
Duplex	
TN-SFP-25G-SR-S	10G/25GBase-SR, SFP28 with DMI 850nm multimode (LC) [100/70 m; 328/230 ft.*] Link Budget:9.0 dB *Distance up to 100m on 50/125 OM4 multimode fiber, up to 70 m for 50/125 um OM3 multimode fiber.
TN-SFP-10/25G-LR-S	10G/25GBase-LR, SFP28 with DMI 1310nm single mode (LC) [10 km / 6.2 mi.] Link Budget: 8.3 dB
TN-SFP-25G-ER	25GBase-ER, SFP28 with DMI 1310nm single mode (LC) [40KM / 24.9 mi.] Link budget: 18.0 dB
Extended Operating Temperature (-40°C to +85°C)	
TN-SFP-25G-BX40U-I	25Gbase-BX, SFP28 with DMI 1270nm TX / 1310nm RX single mode single fiber (LC) [40KM / 24.9 mi.] Link budget: 19.0 dB
TN-SFP-25G-BX40D-I	25Gbase-BX, SFP28 with DMI 1310nm TX / 1270nm RX single mode single fiber (LC) [40KM / 24.9 mi.] Link budget: 19.0 dB

Features

- SFP28 Optical Transceiver with LC connector
- MSA Compliant
- Compliant with 10GBase-xR (TN-SFP-25G-SR-S and TN-SFP-10/25G-LR-S only)
- Compliant with 25GBase-xR
- Compliant with 5G eCPRI
- Single +3.3V Power Supply
- Compliant with SFF-8431 and SFF-8472
- RoHS Compliant

Optical Specifications

The Optical Specs for all Lantronix SFPs are listed at www.transition.com/sfp.pdf.

Specifications and Standards

The TN-SFP-10G-xxx and TN-CWDM-10G-xxx are designed to meet these standards and specifications:

Standards	IEEE 802.3z, IEEE 802.3, IEEE 802.3ae, IEEE 802.3CC
Output Wavelength	$-5.5\text{nm} < \lambda_c < +7.5\text{nm}$
Compliance	IEC-60825, FDA 21, CFR 1040.10 and 1040.11 MSA, 10GBase-xR, 25GBase-xR, 5G eCPRI, SFF-8431, SFF-8472, RoHS Compliant
Dimensions	Width: 0.52" [13 mm] x Depth: 2.18" [55 mm] x Height:0.33" [8 mm]
Power Input	3.3V
Power Dissipation	TN-SFP-25G-SR-S, TN-SFP-10/25G-LR-S, and TN-SFP-25G-ER: < 1.2 Watts
Power Dissipation	TN-SFP-25G-BX40D-I and TN-SFP-25G-BX40U-I: <2W (see Note 1)
Operating Temp	0°C to 70°C (TN-SFP-25G-SR-S, TN-SFP-10/25G-LR-S, TN-SFP-25G-ER)
	-40°C to 85°C (TN-SFP-25G-BX40U-I, TN-SFP-25G-BX40D-I)
Storage Temp	-40°C to +85°C
Warranty	Lifetime

Note 1: the TN-SFP-25G-BX40x-I complies with MSA standard power level 3 (maximum 2.0W power consumption required); the SFP28 slot on host device MUST support power level 3.

Applications

These SFPs are intended for 25G Data Center connectivity, 5G eCPRI Fronthaul and Backhaul, and 25GBase-X Ethernet applications.

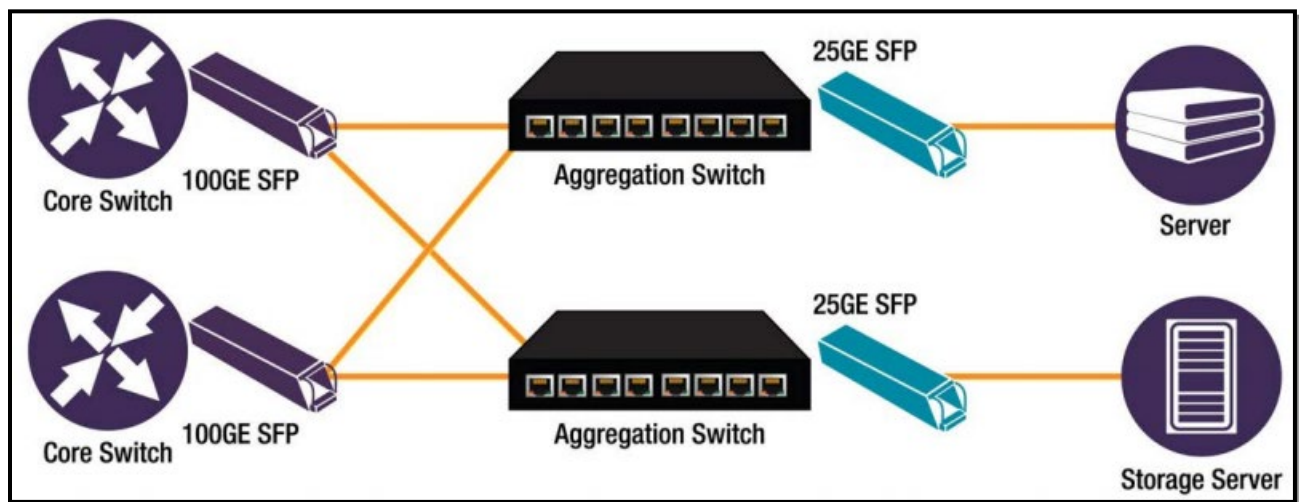
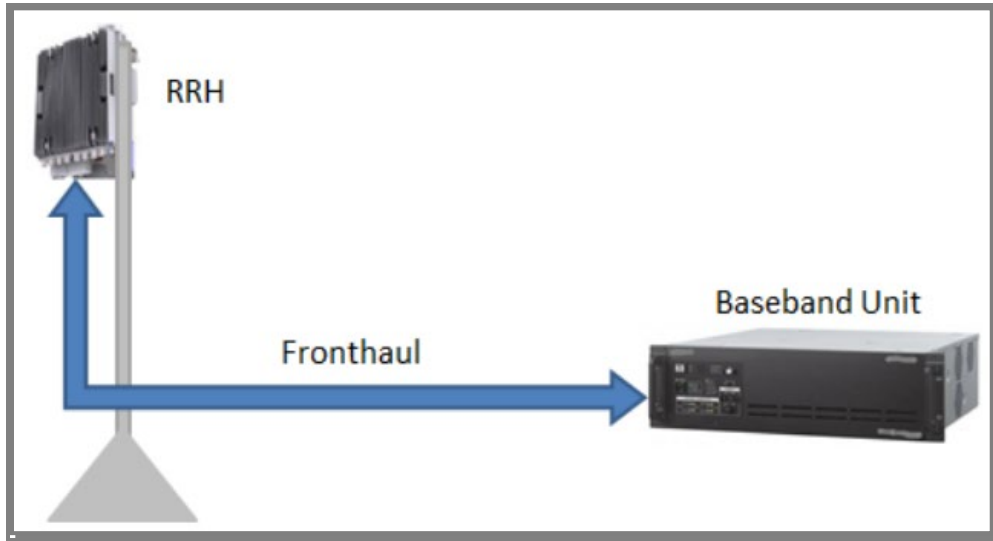

Safety Instructions

When a connector is removed during installation, testing, or servicing, or when an energized fiber is broken, a risk of ocular exposure to optical energy that may be potentially hazardous occurs, depending on the laser output power. The primary hazards of exposure to laser radiation from an optical-fiber system are:

- Damage to the eye by accidental exposure to a beam emitted by a laser source.
- Damage to the eye from viewing a connector attached to a broken fiber or an energized fiber.

Danger: Never attempt to view optical connectors that might be emitting laser energy.

Do not power up the laser product without connecting the laser to the optical fiber and putting the cover in position, as laser outputs will emit infrared laser light at this point.

See the Lantronix [SFP page](#) for our full line of SFP transceivers. See the [FOA webpage](#) for additional information.

High Risk Activities Disclaimer

Components, units, or third-party products used in the product described herein are NOT fault-tolerant and are NOT designed, manufactured, or intended for use as on-line control equipment in the following hazardous environments requiring fail-safe controls: the operation of Nuclear Facilities, Aircraft Navigation or Aircraft Communication Systems, Air Traffic Control, Life Support, or Weapons Systems ("High Risk Activities"). Lantronix and its supplier(s) specifically disclaim any expressed or implied warranty of fitness for such High Risk Activities.

SFP Unpacking

Before you start installing the TN-SFP-xxx, verify that the package contains one TN-SFP-xxx device and one Support Postcard. Notify your sales representative immediately if any of the above items is missing or damaged. Save the packaging for possible future use.

Note: TN-SFP distances, TX power, RX power, and link budgets can be found on Lantronix [website](#). The fiber optic transmitters on this device meet Class I Laser safety requirements per IEC-825/CDRH standards and comply with 21 CFR1040.10 and 21CFR1040.11. **WARNING:** Visible and invisible laser radiation when open. Do not stare into the beam or view the beam directly with optical instruments. Failure to observe this warning could result in an eye injury or blindness.

SFP Installation

Cautions

- The SFP module is keyed to only be installed one way. If forced the wrong way, damage may occur.
- Avoid getting dust or other contaminants into the fiber bore of the SFP transceiver module, as this will cause the optics to not operate properly.
- Clean the optic surfaces of the optical fiber before you plug them back in to the optical bores of another SFP module. See Fiber Optic Association [Cleaning Fiber Optic Connections](#) page.
- Each port must match the wavelength specifications on the other end of the cable, and the cable must not exceed the specified cable length for reliable communications.

Installing an SFP Module

1. Attach an ESD-preventive wrist strap to your wrist and to an ESD ground connector or bare metal surface on the chassis.
2. Remove the SFP transceiver module from its protective packaging. Note: Do not remove the optical bore dust plugs until directed to do so in a later procedure.
3. Check the slot orientation; some slots are "upside down" compared to other slots.
4. Position the SFP device at the desired installation slot, with the label facing correctly.
5. Carefully slide the SFP device into the slot, aligning it with the internal installation guides.
6. Ensure that the SFP device is firmly seated against the internal mating connector. To verify that the SFP is seated and latched properly. **a)** Grasp the SFP by the sides and try to remove it without releasing the latch. **b)** If the SFP cannot be removed, it is installed and seated properly. If the SFP can be removed, reinsert it and press harder with your thumb; repeat if necessary until it is latched securely into the socket.



TN-SFP-10/25G-LR-S (Lever Latched)



TN-SFP-10/25G-LR-S (Lever Latched)

7. Connect the fiber cable to the fiber port connector of the SFP device. Make sure the SFP release latch is in the up (closed) position when you insert the cable connector into the SFP.
8. Remove the dust plug from the connector. Save the dust plug for future use.
9. Attach an appropriate cable into the SFP module port.
10. Attach the other end of the cable into the other device.
11. Observe the status LED(s). See the related manual for details.



TN-SFP-BX40-U-I

TN-SFP-BX40-D-I

Fiber Cable Physical Characteristics

The fiber cable physical characteristics must meet or exceed IEEE 802.3ae specifications:

- Single mode fiber (recommended): 9 μ m
- Multimode fiber (recommended): Distance up to 100m on 50/125 OM4 multimode fiber, up to 70 m for 50/125 μ m OM3 multimode fiber

Warning: Visible and invisible laser radiation when open. DO NOT stare into laser beam or view directly with optical instruments. Failure to observe this warning could result in damage to your eyes or blindness.

Connecting Fiber Cables

To install the fiber cable:

1. Locate the appropriate fiber cable.
2. Install the cable as shown right.



Removing an SFP Module

Caution: Be careful when removing the SFP or SFP+ from a device. Some SFP transceiver module temperatures may exceed 160°F (70°C) and be too hot to touch with bare hands. **Note:** Do not remove and replace the SFP modules more often than necessary; excessive SFP removing and replacing can shorten the SFPs useful life.

1. Attach an ESD-preventive wrist strap to your wrist and to the ESD ground connector or a bare metal surface on your chassis.
2. For future reattachment of fiber-optic cables, note which connector plug is send (TX) and which is receive (RX).
3. Remove the SFP transceiver module:
 - a. If the SFP transceiver module has an **actuator button latch**, gently press the actuator button on the front of the SFP transceiver module until it clicks, and the latch mechanism releases the SFP transceiver module from the socket connector. Grasp the actuator button between your thumb and index finger, and carefully pull the SFP transceiver module straight out of the module slot.
 - b. If the SFP transceiver module has a **bail clasp latch**, pull the latch out and down to eject the SFP transceiver module from the socket connector. If the bail clasp latch is obstructed and you cannot use your index finger to open it, use a small, flat-blade screwdriver or other long, narrow instrument to open the bail clasp latch. Grasp the SFP transceiver module between your thumb and index finger, and carefully remove it from the socket.
4. Replace the Dust Plug.
5. Place the removed SFP/SFP+ transceiver module in an antistatic bag or other protective package.

DDMI (Digital Diagnostics Monitoring Interface)

DDMI (Digital Diagnostics Monitoring Interface) provides enhanced digital DMI for optical transceivers which allows real time access to device operating parameters.

The following DMI port screen and explanation table contains brief definitions of the DDMI support offered on some Small Form Factor Pluggable (SFP) Transceiver Modules. For further information, see the help option or User Guide for the relate product4. **Note:** This feature is not available on all devices and may vary between products. See the related manual for more information.

The screenshot shows a network configuration page for Port 27. It features a left-hand navigation menu with categories like System, Ports, Link OAM, DHCP, Security, LACP, Loop Protection, Spanning Tree, MVR, IPMC, LLDP, Ethernet Services, Performance Monitor, PTP, MAC Table, VLANs, DDMI (with sub-items Overview, Detailed, UOLD), and Diagnostics. The main content area is titled 'Transceiver Information' and includes a table with the following data:

Vendor	Transion
Part Number	TN-10GSFP-LR1
Serial Number	8800022
Revision	0001
Date Code	2011-08-09
Transceiver	10G

Below this is the 'DDMI Information' section, which contains a table with the following data:

Type	Current	High Alarm Threshold	High Warn Threshold	Low Warn Threshold	Low Alarm Threshold
Temperature(C)	52.875	85.000	80.000	0.000	-5.000
Voltage(V)	3.2600	3.6000	3.5000	3.1000	3.0000
Tx Bias(mA)	38.896	90.000	80.000	4.000	2.000
Tx Power(mW)	0.5624	1.4125	1.1220	0.1585	0.1259
Rx Power(mW)	0.0000 --	1.4125	1.1220	0.0363	0.0229
Tx Power(dBm)	-2.50	1.50	0.50	-8.00	-9.00
Rx Power(dBm)	-inf	1.50	0.50	-14.40	-16.40

The Transceiver Information and DDMI Information sections are described below.

DDMI Parameter	Description
Vendor	The SFP vendor's name.
Part Number	The SFP vendor Part number provided by the SFP vendor (<i>TN-10GSFP-SR</i>).
Serial Number	The SFP Vendor Serial number provided by the SFP vendor (e.g., <i>8672105</i>).
Revision	The SFP vendor Revision level for part number provided by the SFP vendor.
Date Code	The vendor's manufacturing date code (e.g., <i>2011-08-09</i>).
Transeiver	The Transceiver compatibility (e.g., <i>1000BASE_SX</i> or <i>10G</i>).
Current	The current value of temperature, voltage, TX bias, TX power, and RX power.
High Alarm Threshold	The high alarm threshold value - temperature, voltage, TX bias, TX power, - RX power.
High Warn Threshold	The high warn threshold value of temperature, voltage, TX bias, TX power, RX power.
Low Warn Threshold	The low warn threshold value of temperature, voltage, TX bias, TX power, RX power.
Low Alarm Threshold	The low alarm threshold value - temperature, voltage, TX bias, TX power, RX power.

SFP Information and SFP Detail Info

Note: This feature is not available on all devices and may vary between products. See the related manual for more information.

SFP Information

This page displays general SFP information and monitoring information as shown and described below.

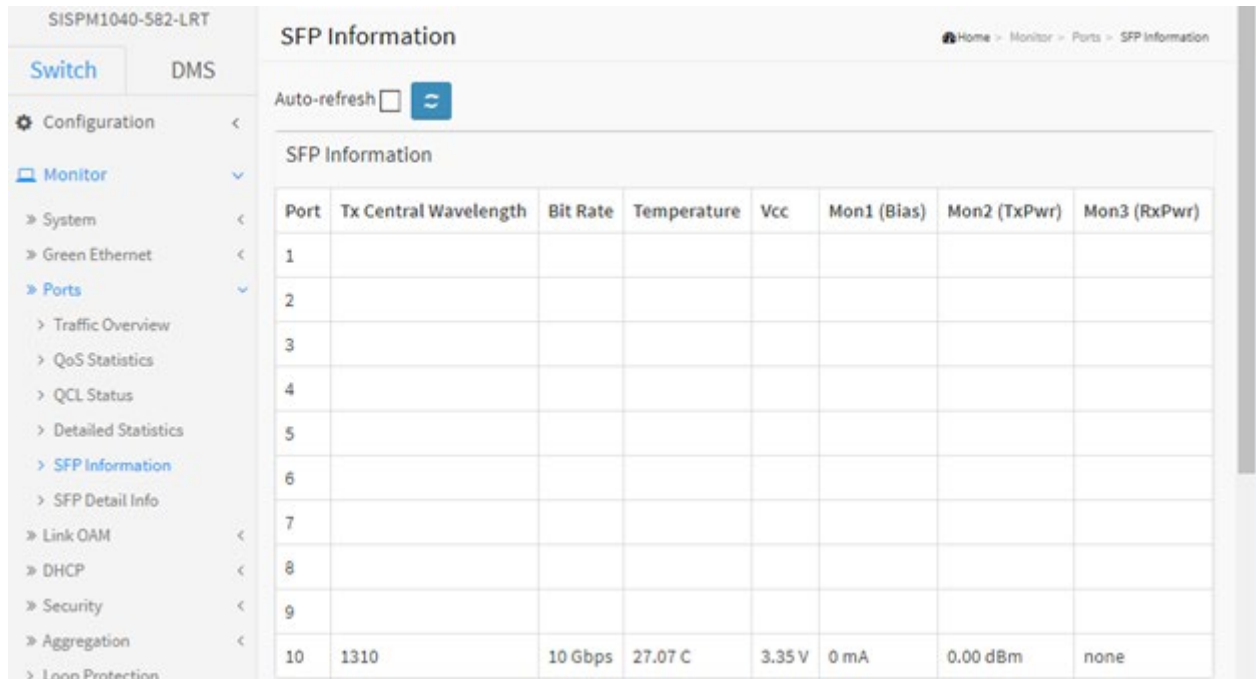

Parameter descriptions:

Parameter	Description
Port	The logical port for the settings contained in the same row.
Tx Central Wavelength	Displays the nominal transmitter output wavelength in nm.
Bit rate	Displays the nominal bit rate of the transceiver.
Temperature	Displays the internally measured transceiver temperature. Temperature accuracy is vendor specific but must be better than 3 degrees Celsius over specified operating temperature and voltage.
Vcc	Displays the internally measured transceiver supply voltage. Accuracy is vendor specific but must be better than 3 percent of the manufacturer's nominal value over specified operating temperature and voltage. Note that in some transceivers, transmitter supply voltage and receiver supply voltage are isolated. In that case, only one supply is monitored. Refer to the device specification for more detail.
Mon1 (Bias)	Displays the measured TX bias current in uA. Accuracy is vendor specific but must be better than 10 percent of the manufacturer's nominal value over specified operating temperature and voltage.
Mon2 (TX PWR)	Displays the measured coupled TX output power in mW. Accuracy is vendor specific but must be better than 3dB over specified operating temperature and

	voltage. Data is assumed to be based on measurement of a laser monitor photodiode current. Data is not valid when the transmitter is disabled.
Mon3 (RX PWR)	Displays the measured received optical power in mW. Absolute accuracy is dependent upon the exact optical wavelength. For the vendor specified wavelength, accuracy should be better than 3dB over specified temperature and voltage. This accuracy should be maintained for input power levels up to the lesser of maximum transmitted or maximum received optical power per the appropriate standard. It should be maintained down to the minimum transmitted power minus cable plant loss (insertion loss or passive loss) per the appropriate standard. Absolute accuracy beyond this minimum required received input optical power range is vendor specific.

SFP Detail Info

This page displays detailed SFP information and monitoring information as shown and described below.

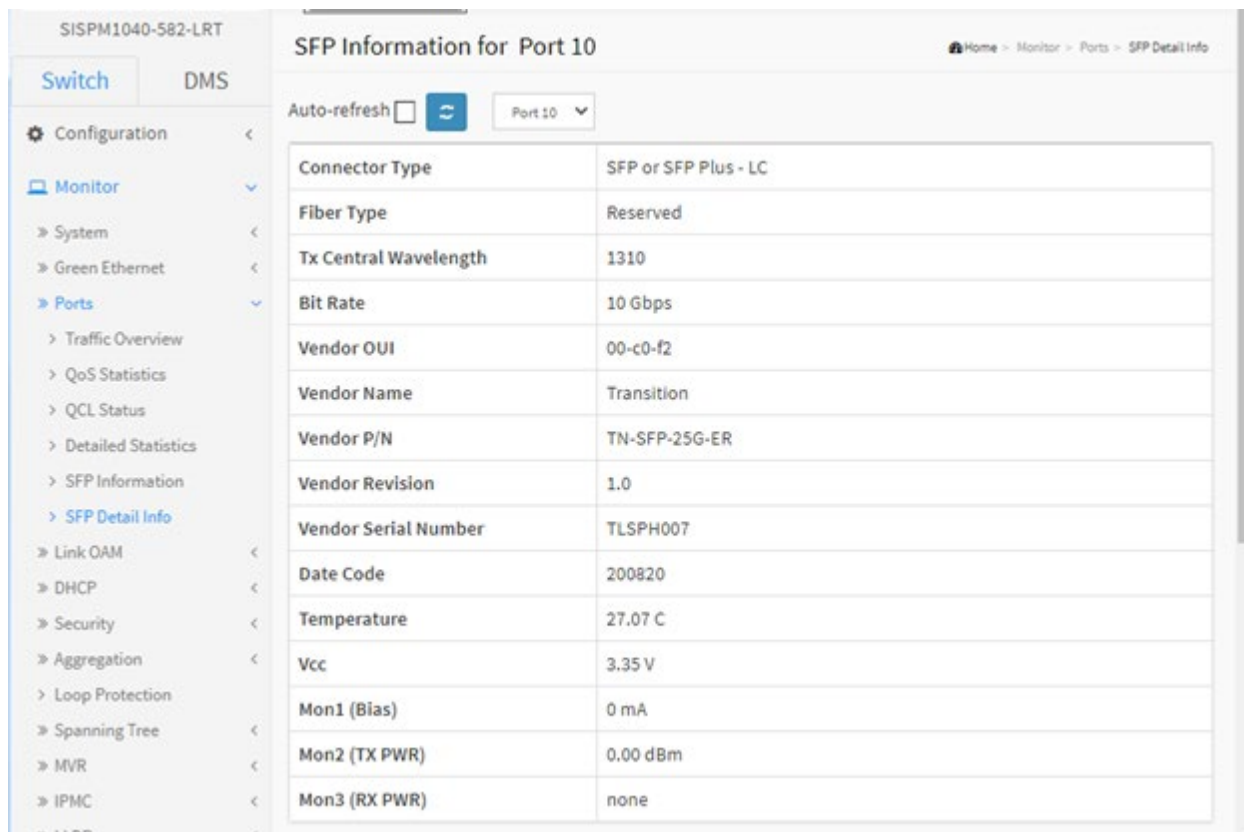

Parameter descriptions:

Parameter	Description
Connector Type	Displays the external optical or electrical cable connector provided as the media interface.
Fiber Type	Displays the fiber channel transmission media.
Tx Central Wavelength	Displays the nominal transmitter output wavelength in nm.
Bit rate	Displays the nominal bit rate of the transceiver.
Vendor OUI	Displays the vendor IEEE company ID (Organizationally Unique Identifier).

Vendor Name	Displays the vendor name.
Vendor P/N	Displays the vendor part number or product name (e.g., TN-SFP-25G-ER).
Vendor Revision	Displays the vendor product revision.
Vendor Serial Number	Displays the vendor serial number for the transceiver.
Date Code :	Displays the vendor's manufacturing date code.
Temperature	Displays the internally measured transceiver temperature. Temperature accuracy is vendor specific but must be better than 3 degrees Celsius over specified operating temperature and voltage.
Vcc	Displays the internally measured transceiver supply voltage. Accuracy is vendor specific but must be better than 3 percent of the manufacturer's nominal value over specified operating temperature and voltage. Note that in some transceivers, transmitter supply voltage and receiver supply voltage are isolated. In that case, only one supply is monitored. Refer to the device specification for more detail.
Mon1 (Bias)	Displays the measured TX bias current in uA. Accuracy is vendor specific but must be better than 10 percent of the manufacturer's nominal value over specified operating temperature and voltage.
Mon2 (TX PWR)	Displays the measured coupled TX output power in mW. Accuracy is vendor specific but must be better than 3dB over specified operating temperature and voltage. Data is assumed to be based on measurement of a laser monitor photodiode current. Data is not valid when the transmitter is disabled.
Mon3 (RX PWR)	Displays the measured received optical power in mW. Absolute accuracy is dependent upon the exact optical wavelength. For the vendor specified wavelength, accuracy should be better than 3dB over specified temperature and voltage. This accuracy should be maintained for input power levels up to the lesser of maximum transmitted or maximum received optical power per the appropriate standard. It should be maintained down to the minimum transmitted power minus cable plant loss (insertion loss or passive loss) per the appropriate standard. Absolute accuracy beyond this minimum required received input optical power range is vendor specific.

For More Information

Technical information in this document is subject to change without notice. For more information see our online [Optical Devices Product Catalog](#) or our [SFP Specifications](#) page.

The Fiber Optic Association, Inc. is the international professional association of fiber optics. The FOA is an international non-profit educational association chartered to promote professionalism in fiber optics through education, certification and standards. FOA creates and publishes its own technical materials for training and reference based on a worldwide network of technical advisors. See <https://foa.org/foa.htm>.

Compliance Information

Class I Laser Compliance

This product has been tested and found to comply with the limits for FDA Class I laser for IEC60825, EN60825, and 21CFR1040 specifications.

Translated Safety Warnings

Warning Class I laser product.

Waarschuwing Klasse-I laser produkt.

Varoitus Luokan I lasertuote.

Attention Produit laser de classe I

Warnung Laserprodukt der Klasse I.

Avvertenza Prodotto laser di Classe I.

Advarsel Laserprodukt av klasse I.

Aviso Produto laser de classe I.

¡Advertencia! Producto láser Clase I.

Varning! Laserprodukt av klass I.

Aviso Produto a laser de classe I.

Advarsel Klasse I laserprodukt.

FCC Regulations

This equipment has been tested and found to comply with the limits for a Class A digital device, pursuant to Part 15 of the FCC rules. These limits are designed to provide reasonable protection against harmful interference when the equipment is operated in a commercial environment. This equipment generates, uses and can radiate radio frequency energy and, if not installed and used in accordance with the instruction manual, may cause harmful interference to radio communications.

Operation of this equipment in a residential area is likely to cause harmful interference, in which case the user will be required to correct the interference at the user's own expense.

Canadian Regulations

This digital apparatus does not exceed the Class A limits for radio noise for digital apparatus set out on the radio interference regulations of the Canadian Department of Communications.

Le présent appareil numérique n'émet pas de bruits radioélectriques dépassant les limites applicables aux appareils numériques de la Class A prescrites dans le Règlement sur le brouillage radioélectrique édicté par le ministère des Communications du Canada.

European Regulations

Warning : This is a Class A product. In a domestic environment this product may cause radio interference in which case the user may be required to take adequate measures.

Achtung ! : Dieses ist ein Gerät der Funkstörgrenzwertklasse A. In Wohnbereichen können bei Betrieb dieses Gerätes Rundfunkstörungen auftreten. In diesem Fall ist der Benutzer für Gegenmaßnahmen verantwortlich.

Attention ! : Ceci est un produit de Classe A. Dans un environnement domestique, ce produit risque de créer des interférences radioélectriques, il appartiendra alors à l'utilisateur de prendre les mesures spécifiques appropriées.



In accordance with European Union Directive 2002/96/EC of the European Parliament and of the Council of 27 January 2003, Lantronix will accept post usage returns of this product for proper disposal. The contact information for this activity can be found in the 'Contact Us' portion of this document.

Der Anschluss dieses Gerätes an ein öffentliches Telekommunikationsnetz in den EGMitgliedstaaten verstösst gegen die jeweiligen einzelstaatlichen Gesetze zur Anwendung der Richtlinie 91/263/EWG zur Angleichung der Rechtsvorschriften der Mitgliedstaaten über Telekommunikationsendeinrichtungen einschliesslich der gegenseitigen Anerkennung ihrer Konformität.



CAUTION: RJ connectors are NOT INTENDED FOR CONNECTION TO THE PUBLIC TELEPHONE NETWORK. Failure to observe this caution could result in damage to the public telephone network.

Der Anschluss dieses Gerätes an ein öffentliches Telekommunikationsnetz in den EGMitgliedstaaten verstösst gegen die jeweiligen einzelstaatlichen Gesetze zur Anwendung der Richtlinie 91/263/EWG zur Angleichung der Rechtsvorschriften der Mitgliedstaaten über Telekommunikationsendeinrichtungen einschliesslich der gegenseitigen Anerkennung ihrer Konformität.

**Lantronix Corporate Headquarters**

7535 Irvine Center Drive

Suite100

Irvine, CA 92618, USA

Toll Free: 800-526-8766

Phone: 949-453-3990

Fax: 949-453-3995

Technical Support

Online: <http://www.transition.com/support>.

Sales Offices

For a current list of our domestic and international sales offices, go to the Lantronix web site at www.lantronix.com/about/contact.