

# EDCA-DIO-01

## Enclosure Door Contact Alarm

### Quick Start Guide

**Note:** See the Install Guide for important information.

### Product Description

The Lantronix EDCA-DIO-01 Enclosure Door Contact Alarm adds an additional level of security to applications by monitoring the status of the door on equipment enclosures. The EDCA-DIO-01 inserts power into any 12V Digital Input (DI) application by making it active.



### Specifications

IEEE, IETF, Safety Compliance	N/A
Regulatory Compliance - Emission	EN 55032
Regulatory Compliance - Immunity	EN 55024
Power Consumption	1.2W (100mA at 12V out max.)
Power Source	20-60 VDC
Power Output	12VDC +/- 10%
Dimensions	2.2" x 2" x 7/8" (6.2 x 5 x 2.2 cm)
Weight	0.2 Lb. (0.09 Kg.)
Environment	Oper. Temp: -25 to +75° C. Storage: -40 to +85° C. Altitude: 0-10,000 ft. Oper. Humidity: 5% to 95% (non-condensing)
Warranty	Lifetime

### Installation

**Package Contents:** Carefully unpack the EDCA-DIO-01 and verify you have received one EDCA-DIO-01, one printed Quick Start Guide, a DIN Rail Clip and one Support Postcard.

**DIN Rail Clip Installation:** Attach and tighten the DIN rail clip on the threaded stud until it is secured and aligned properly.

**Wall Mount Plate Installation (Optional):** **1.** Attach the Wall Mount Plate to the EDCA-DIO-01 using the two provided screws. **2.** Attach the Wall Mount Plate to the enclosure wall using Velcro, industrial tape, nuts and bolts, super glue, rivets, etc. (not provided).

### EDCA-DIO-01 Installation

The EDCA-DIO-01 requires power and can be powered by the same power supply providing power to the Lantronix Ethernet switch in the cabinet. The power port (marked DC Input) is a 2-wire Terminal Block supporting 20 - 60 VDC. The DI ports must also be 2-wire terminal blocks on the Lantronix Ethernet switch. Lantronix sells as an optional accessory a universal mechanical door contact closure switch that works with a variety of enclosures. However, your cabinet manufacturer may provide a door closure contact switch. The switch requires wire connection terminals.

The figure below shows a SISPM1040-384-LRT-C Ethernet switch, EDCA-DIO-01, and power supply in a single cabinet/enclosure. **Warning:** Ensure that the target alarm input can accept the applied voltage (12VDC in this example).

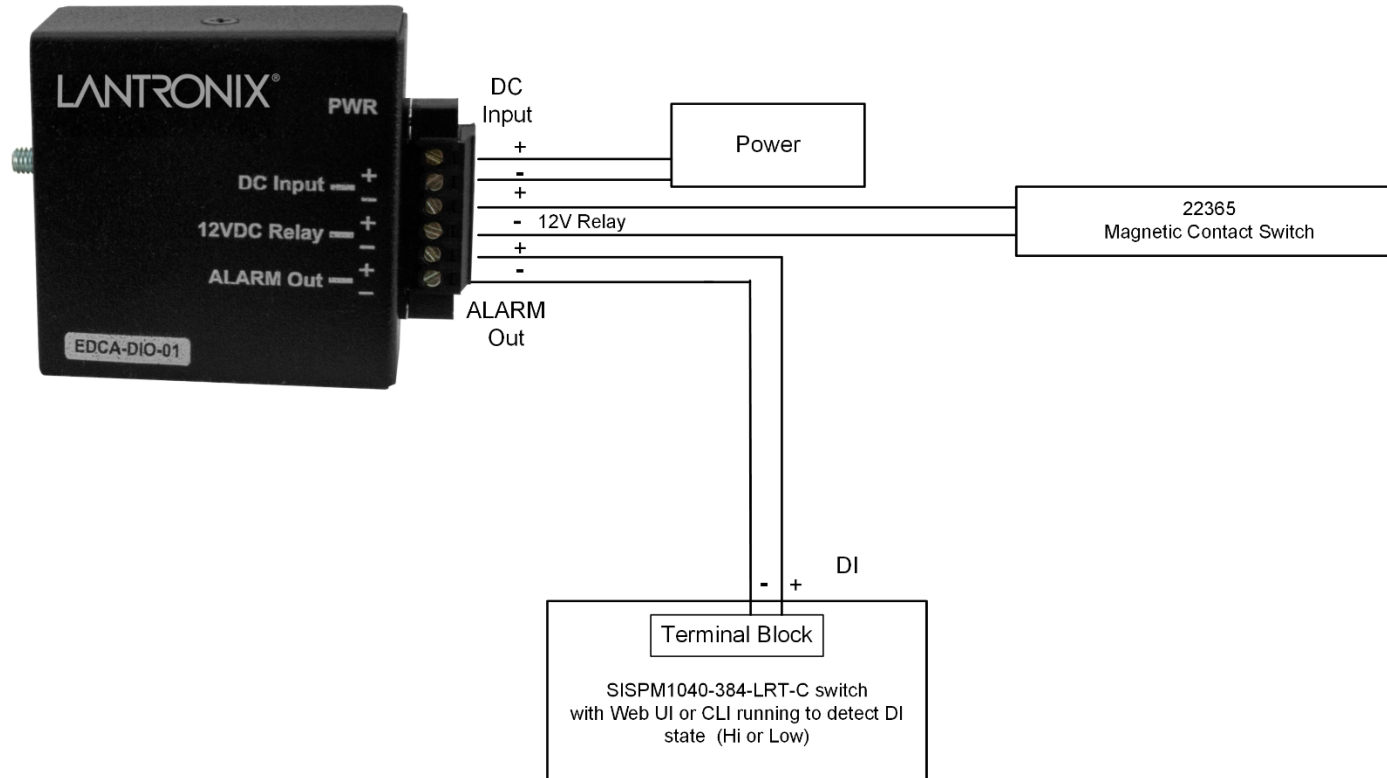

**Note:** If installing external audio or visual alarm equipment, place that equipment in series with the 22365 or switch that came with the cabinet.

### EDCA-DIO-01 Install Procedure

1. Mount a mechanical door closure contact switch near the enclosure door so that the opening and closing of the door will trigger the switch.
2. Connect the **12VDC Relay** port to the sensor or door contact closure switch.
3. Connect the **ALARM Out** port to the Digital input port on the Ethernet Switch.
4. Connect to **DC Input** power last.
5. Verify that the **PWR** LED is lit.

### Switch Software Configuration

When the EDCA-DIO-01 is installed with a Lantronix managed hardened Ethernet PoE switch, you can set up alarm notifications and clear the logged alarm from either the switch Web Interface or CLI. See the related manual for your switch model.

**Contact Us:** 48 Discovery, Suite 250, Irvine, CA 92618, USA. Toll Free: 800-526-8766. Phone: 949-453-3990. Fax: 949-453-3995. **Technical Support** Online: <https://www.lantronix.com/technical-support/> **Sales Offices:** [www.lantronix.com/about/contact](http://www.lantronix.com/about/contact).