

PS-DC-DUAL-5624T

345 Watt Isolated Power Supply with 56VDC and 24VDC Dual Output

Quick Start Guide



The Power Supply provides 345W at 56VDC and is targeted for PoE applications.

The Power Supply is fully compliant with IEEE 802.3af, at, and bt PoE standards for isolation. It provides a secondary fully-isolated 24V at 1.25A (30W) output for other equipment.

Note: See the Install Guide for important Cautions and Warnings, Introduction, Ordering Information, Features, Specs, Connectors & LEDs, Dimensions, Power cords, Front panel, Installation, Unpacking, Mounting, Grounding, POWER OUTPUT & AC INPUT, LEDs, Fuse Replacement, Troubleshooting, Compliance, Electrical Safety Warnings, and Warranty.

Connectors and LEDs

AC Input: IEC C14 Connector; 6.3A slo blo Fuse; Power On/Off switch.

56VDC and 24VDC output: 6-Pin Terminal Block: **Pin 1:** 24Vout+. **Pin 2:** 24Vout-. **Pin 3:** Alarm Contacts 1.

Pin 4: Alarm Contacts 2. **Pin 5:** 56Vout+. **Pin 6:** 56Vout-.

LEDs: Power status: **Green:** OK. **Yellow blink:** Will cycle through if one or more events (alarms) occur with a Blink Rate: **1** blink per 3 seconds: Fan locked (no tach). **2** blinks per 3 seconds: Fan less than 30% PWM (Pulse Width Modulation) setting. **3** blinks per 3 seconds: 24VDC output out of spec. **4** blinks per 3 seconds: Exceeding -25 Deg. C. **5** blinks per 3 seconds: Exceeding +75 Deg. C. If more than one alarm is set the LED will cycle through the Blink Rates one at a time, and then repeat until the alarm is cleared. The Blink Rates include a 3 second alarm delay to prevent triggering a false alarm when the fan ramps up or down.

Power Cords: Locking and non-locking line cords are available. See the Install Guide.

Front Panel: shown and described below. See the Installation section for grounding and connection.



On / Off switch: The power on/power off switch is labeled **O** (off) / **|** (on).

FUSE: The fuse can be replaced without opening the chassis; see [Fuse Replacement](#) in the Install Guide.

AC INPUT Power connection: labeled 100 - 240VAC 50/60 Hz; see [Connecting AC INPUT](#) below.

POWER OUTPUT Terminal Block: is labeled 56 VDC - and +, ALARM, and 24 VDC - and +.

Unpacking: Carefully unpack the Power Supply. Verify you have received: one Power Supply, one Postcard, one printed Quick Start Guide, one AC Power Cord, and four Rubber Feet.

Mounting: Desktop: Attach the 4 adhesive-backed rubber feet to the bottom of the power supply for desktop mounting.

DIN Rail: The power supply ships with a DIN rail mounting bracket attached. **Caution:** If mounted in a NEMA rated enclosure, either vertical direction is allowed. In a standard 19" rack, the side holes must face upward. To DIN rail mount the power supply: **1.** Ensure at least 2 inches of open space outside of at least one of the two vented sides. **2.** Hang the top of the DIN rail bracket on the DIN rail. **Caution:** The DIN Rail Spring Clip must be facing upwards. **3.** Click the bottom of the DIN rail bracket onto the DIN rail.

Grounding: Use appropriate gauge wire to connect the Phillips head Ground screw to ground following your organization’s grounding procedures.

Operating Temperature - RESTRICTED ACCESS LOCATION: See the Install Guide.



WARNING HOT SURFACE DO NOT TOUCH

Connecting POWER OUTPUT: The Terminal Block is labeled 56 VDC - and +, ALARM, and 24 VDC - and +. Use 14 AWG stranded or better wire (typ.) to connect to 56 VDC@ 315W. Use 20 AWG stranded or better wire (typ.) to connect to 24 VDC@30W.

Connecting AC INPUT: Connect the male end of the provided AC power cord to the power supply AC input first, and then connect the other end to a live 3-prong outlet.

PWR (Power) LED: When the bi-color green/yellow PWR LED is lit green, the power being supplied is OK. If the bi-color green/yellow LED is blinking yellow, a fan, voltage, or temperature event is occurring (see LED Blink Rate above).

Add TN 16210 Ferrite: For EMC reasons, install a snap-on ferrite, TN 16210, over the 24 VDC output wires after installation: **1.** Open Ferrite. **2.** Place Ferrite over the 24 VDC Output. **3.** Snap Ferrite in place.

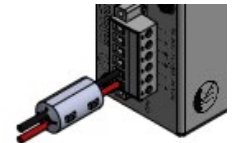

Fuse Replacement: The AC INPUT is labeled 100-240VAC 50/60Hz 5.5A. The Fuse is a 5x20mm 6.3A/250V SB (slo blo) externally-accessible fuse. **Warning:** Disconnect all Power sources before servicing.

Caution: Replace fuse with same Type & Rating!

Application Example: a SISPM1040-384-LRT-C switch, Enclosure Door sensor, and PS-DC-DUAL-5624T power supply.

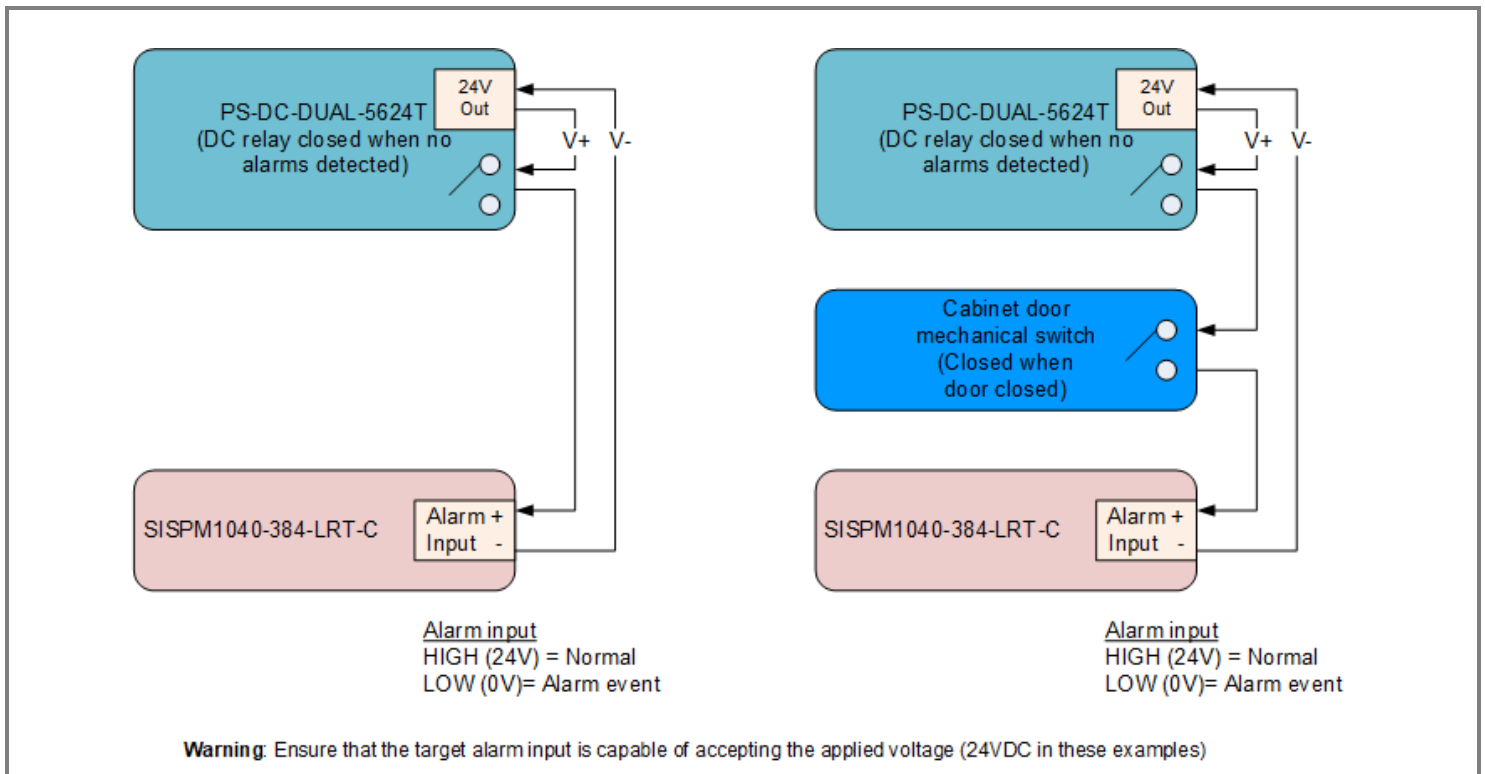

Troubleshooting: **1.** Check the PWR LED for status; see the PWR (Power) LED description above. **2.** Verify the AC power source is good (a live 3-prong outlet). **3.** Make sure the fuse is not blown; replace if necessary. **4.** Check the LED for On or alarm event blinking. A short or overload of the 56V will be indicated by no power LED or possibly a quick On/Off cycling. A short or overload of the 24V output will be indicated by “24VDC output out of spec” LED blink rate.

Contact Us: 48 Discovery, Suite 250, Irvine, CA 92618, USA. Toll Free: 800-526-8766. Phone: 949-453-3990.

Fax: 949-453-3995. **Technical Support** Online: <https://www.lantronix.com/technical-support/>

Sales Offices: www.lantronix.com/about/contact.