



## M/GE-UxX Series

### Mini Gigabit Ethernet Uni-Directional Media Converters

10/100/1000Base-T Port to 100/1000Base-X Port

## User Guide

**Part Number 33781**

Revision D October 2024

## Intellectual Property

© 2022-2024 Lantronix, Inc. All rights reserved. No part of the contents of this publication may be transmitted or reproduced in any form or by any means without the written permission of Lantronix.

*Lantronix* is a registered trademark of Lantronix, Inc. in the United States and other countries.

All other trademarks and trade names are the property of their respective holders.

Patented: <https://www.lantronix.com/legal/patents/>; additional patents pending.

## Warranty

For details on the Lantronix warranty policy, go to <http://www.lantronix.com/support/warranty>.

## Contacts

### Lantronix Corporate Headquarters

48 Discovery, Suite 250

Irvine, CA 92618, USA

Toll Free: 800-526-8766

Phone: 949-453-3990

Fax: 949-453-3995

### Technical Support

Online: <https://www.lantronix.com/technical-support/>

### Sales Offices

For a current list of our domestic and international sales offices, go to [www.lantronix.com/about/contact](http://www.lantronix.com/about/contact).

## Disclaimer

All information contained herein is provided "AS IS." Lantronix undertakes no obligation to update the information in this publication. Lantronix does not make, and specifically disclaims, all warranties of any kind (express, implied or otherwise) regarding title, non-infringement, fitness, quality, accuracy, completeness, usefulness, suitability or performance of the information provided herein. Lantronix shall have no liability whatsoever to any user for any damages, losses and causes of action (whether in contract or in tort or otherwise) in connection with the user's access or usage of any of the information or content contained herein. The information and specifications contained in this document are subject to change without notice.

## Revision History

Date	Rev.	Description
A	6/4/19	Initial release of the M/GE-xSW-SFP-01-xx-UxX Series.
B	2/12/21	Remove FEF, LPT, and FC details as they are not supported. Replace PS 25083 with 25165.
C	1/10/23	Initial Lantronix rebrand. Update artwork.
D	10/16/24	Add TAA and NDAA Compliant and fix typo.

## Contents

<b>Revision History</b> .....	<b>2</b>
<b>1. Product Description</b> .....	<b>4</b>
Features.....	4
Feature Benefits .....	4
Ordering Information.....	5
Family Portrait.....	6
Applications .....	7
Application Examples .....	7
Package Contents and Unpacking .....	8
Power Cord Included .....	8
For More Information .....	8
Related Manuals.....	8
<b>2. Installation</b> .....	<b>9</b>
Cautions and Warnings .....	9
Electrostatic Discharge (ESD).....	9
Front Panel Copper and Fiber Ports.....	9
Connect Fiber Cables .....	10
Connect Twisted-pair Copper Cable .....	11
Insert and Connect the SFP .....	12
Removing an SFP Module.....	13
Mounting Options.....	13
Installing DIN Rail Clip.....	14
Connecting Power .....	15
<b>3. Operation</b> .....	<b>16</b>
Status LEDs.....	16
Feature Descriptions .....	17
Fiber Cable and Optic Specifications .....	18
<b>4. Related Information</b> .....	<b>20</b>
Specifications.....	20
Troubleshooting.....	21
Compliance Information.....	22
Electrical Safety Warnings.....	24

## 1. Product Description

Lantronix M/GE-xSW-SFP-01-xx-UxX Series are 10/100/1000Base-T to 100/1000Base-X Mini Gigabit Ethernet Uni-Directional Media Converters.

Uni-directional communication is often used to safeguard information in secure environments such as government agencies and military networks. A uni-directional device, sometimes referred to as a uni-directional security gateway or a data diode, provides a connection between two or more networks with different security classifications and helps to protect assets by ensuring information is directed only to, or from, the appropriate network as designated by the directional device.

Uni-directional media converters combine this one-way communications with the benefits of a copper to fiber media converter. Media converters are generally cost-effective, plug-and-play devices that allow fiber optic cabling to be connected to copper-based networking equipment. The deployment of fiber adds a layer of security to networks as it is difficult to tap into fiber and go undetected. If threats are attacking a network, the fiber links usually go down and network administrators are made aware of the problem, providing them the opportunity to address a potential breach of security.

Adding uni-directional technology to a media converter creates a physically secure one-way communication channel between a secure network and an unsecure network. These devices can be used to allow data from a classified, high-security area to be transmitted to a low-security area, while preventing unsecure data from reentering the classified network. An alternative application allows a secure network to be updated with data from an external source while ensuring its critical data is unable to leave the classified area.

### Features

- Unidirectional data transmissions over one strand of fiber to, or from, secure networks
- Applications require a transmit-only converter to be paired with a receive-only converter
- Support dual speed 100/1000Mbps SFP modules
- Unit and Port LEDs for quick status
- Auto MDI/MDX configuration and Jumbo Frame support
- Auto-Negotiation on the 10/100/1000 copper port
- Enterprise Grade, Hardened Grade, and PoE-Powered Hardened Grade converters available

### Feature Benefits

- Uni-directional data transmissions to, or from, secure networks.
- Simplex communications only requires one strand of fiber cable.
- Applications require a transmit-only converter to be paired with a receive-only converter.
- Converters support dual speed 100/1000Mbps SFP modules offering great flexibility to meet network requirements.
- Converters use duplex SFP modules but the transmitting converter only uses the TX port on the SFP, while the RX port is deactivated. Likewise the receiving converter only uses the RX port, while the TX port is deactivated.
- Secure transmission of data where two-way communication is undesirable.
- Provides a highly reliable, tamper proof converter for uni-directional transmission.
- Allows the transmission of data from a secure area to an unsecure area, while preventing unsecure data from getting back into the secure area.
- Secured mirroring and recording at off-site location.

## Ordering Information

There are six available SKUs with three paired combinations; each pair consists of one Transmit converter and one Receive converter:

- M/GE-ISW-SFP-01-PD-UTX and -URX
- M/GE-ISW-SFP-01-UTX and -URX
- M/GE-PSW-SFP-01-UTX and -URX

The M/GE-xSW-SFP-01-xx-UxX series includes:

SKU	Description
<b>Enterprise Grade Converters (0°C to +50°C)</b>	
M/GE-PSW-SFP-01-UTX	10/100/1000Base-T (RJ-45) [100 m/328 ft.] to 100/1000Base-X SFP Slot (empty) Uni-directional Transmitting Converter
M/GE-PSW-SFP-01-URX	10/100/1000Base-T (RJ-45) [100 m/328 ft.] to 100/1000Base-X SFP Slot (empty) Uni-directional Receiving Converter
<b>Hardened Grade Converters (-40°C to +75°C)</b>	
M/GE-ISW-SFP-01-UTX	Hardened Mini 10/100/1000Base-T (RJ-45) to 100/1000Base-X Open SFP Slot Uni-directional Transmitting Converter
M/GE-ISW-SFP-01-URX	Hardened Mini 10/100/1000Base-T (RJ-45) to 100/1000Base-X Open SFP Slot Uni-directional Receiving Converter
<b>PoE-Powered Hardened Grade Converters (-40°C to +75°C)</b>	
M/GE-ISW-SFP-01-PD-UTX	PoE Powered Hardened Mini; 10/100/1000Base-T (RJ-45) to 100/1000Base-X Open SFP Slot Uni-directional Transmitting Converter
M/GE-ISW-SFP-01-PD-URX	PoE Powered Hardened Mini; 10/100/1000Base-T (RJ-45) to 100/1000Base-X Open SFP Slot Uni-directional Receiving Converter
<b>Power Supply Options</b>	
SPS-2460-SA	Power Supply, 24VDC to 60VDC input Stand-alone (for Enterprise Converters) (must be ordered separately)
SPS-UA12DHT	External AC/DC Desktop Power Supply, 12 VDC, 18W (for Hardened Non-PD Converters)
25165	Universal AC/DC Input DIN Rail Mountable +12 VDC Power Supply (for Hardened Non-PD Converters)
<b>Mounting Options</b>	
WMBM	Wall Mount Bracket for Mini (for Enterprise Converters)
M-MCR-01	18-Slot Powered Mini Chassis (for Enterprise Converters)
DRBM	DIN Rail Mount Bracket for Mini (for Enterprise Converters)
RMBM	Rack Mount Bracket for Mini, use with RMS19-SA4-02 and/or E-MCR-05
<b>SFP Module Options</b>	
TN-xxXSFP-xxx	These converters support dual speed 100/1000Mbps SFP modules. For Lantronix full line of small form factor pluggable (SFP) transceivers see our <a href="#">SFP webpage</a> .

**Note:** Typical maximum cable distance. Actual distance depends on network physical characteristics. For more information, see <https://www.lantronix.com/>.

### Family Portrait

The figure below shows the six available SKUs in the three paired combinations.



## Applications

The M/GE-xSW-SFP-01-xx-UxX can be used in applications such as:

- Transmit data from a classified, high-security area to a low-security area
- Update secure data on a secure network from an unsecure external source

These applications are shown and described below.

## Application Examples

The figure below shows M/GE-xSW-SFP-01-xx-UxX deployed to ensure a secure data environment. These devices allow data from a classified, high-security area to be transmitted to a low-security area, while preventing unsecure data from re-entering the classified network. **Benefits:** protect assets and data, block access to the secure area, and prevent manipulation of secure data.

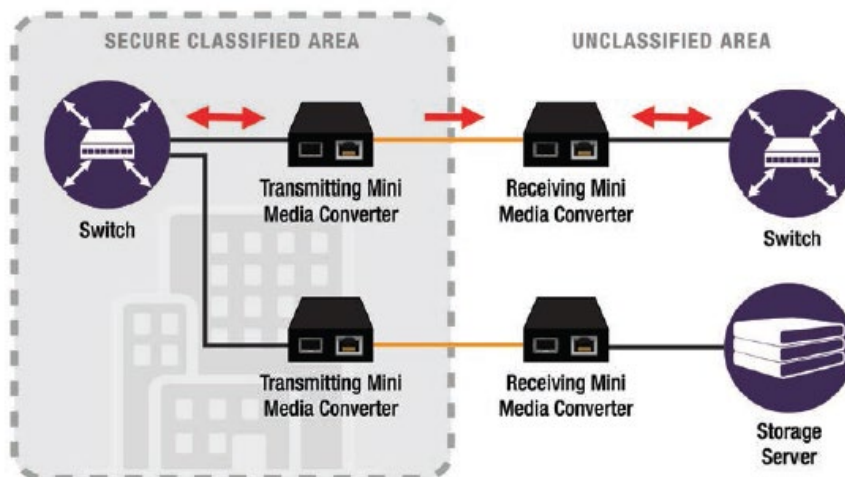

The figure below shows a secure network that needs to be updated with data from an unsecure external source, where it can be analyzed and used to make key decisions. Unidirectional communication ensures no data is able to leave the classified area. **Benefits:** maintain integrity of data in secured area, block classified data from leaking out of the secured area, and allow databases to be updated with current information.

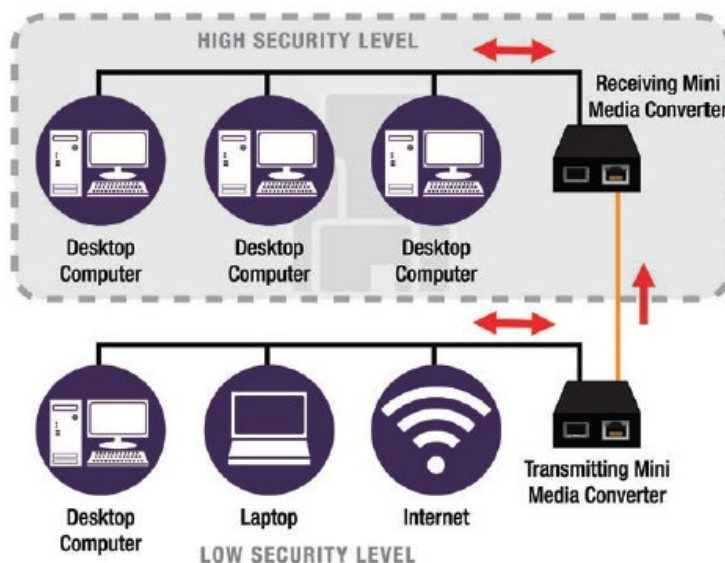

## Package Contents and Unpacking

Verify you have received the following items. Contact your sales representative if any item is missing or damaged. Please save the packaging for possible future use.

- M/GE-xSW-SFP-01-xx-UxX Series media converters (one Transmit converter & one Receive converter)
- Power Supply ordered and packaged separately for the M/GE-ISW-SFP-01-UxX converters.  
Power Supply included with the M/GE-PSW-SFP-01-UxX-xx.  
Power Supply not needed with the PoE powered M/GE-ISW-SFP-01-PD-UxX.
- Mounting Brackets (ordered and packaged separately)
- Documentation Postcard

## Power Cord Included

To order the corresponding country-specific power cord, add the extension to the end of the SKU (for M/GE-PSW-SFP-01-UTX-xx and M/GE-PSU-SFP-01-URX-xx only): -NA = North America, -LA = Latin America, -EU = Europe, -UK = United Kingdom, -SA = South Africa, -JP = Japan, -OZ = Australia, and -BR = Brazil.

## For More Information

For Lantronix Drivers, Firmware, Manuals, Product Notifications, Warranty Policy & Procedures, etc. go to the Lantronix [Technical Resource Center](#).

**Note:** Information in this document is subject to change without notice. Note that this manual provides links to third party web sites for which Lantronix is not responsible.

## Related Manuals

- SPS-2460-SA Power Supply User Guide, 33455
- SPS-UA12DHT Power Supply Datasheet
- 25165 Power Supply Datasheet
- WMBM Wall-Mount Bracket Install Guide, 33393
- M-MCR-01 User Guide, 33628
- DRBM Mounting Brackets Datasheet
- RMBM Mounting Brackets Datasheet
- SFP manuals



## 2. Installation

### Cautions and Warnings

**Cautions** indicate that there is the possibility of poor equipment performance or potential damage to the equipment. **Warnings** indicate that there is the possibility of injury to person.

Cautions and Warnings appear here and may appear throughout this manual where appropriate. Failure to read and understand the information identified by this symbol could result in poor equipment performance, damage to the equipment, or injury to persons.

See [Electrical Safety Warnings](#) on page 24 for Electrical Safety Warnings translated into multiple languages.

### Electrostatic Discharge (ESD)

Observe these ESD precautions when installing or handling the M/GE-xSW-SFP-01-xx-UxX:

- Do not remove the converter from its protective packaging until you are ready to install M/GE-xSW-SFP-01-xx-UxX Series media converter.
- Wear an ESD wrist grounding strap before handling the M/GE-xSW-SFP-01-xx-UxX Series media converter or its component. If you do not have a wrist strap, maintain grounded contact with the unit throughout any procedure requiring ESD protection.

### Front Panel Copper and Fiber Ports

The figure below shows the front panel of the M/GE-xSW-SFP-01-xx-UxX Series media converters.

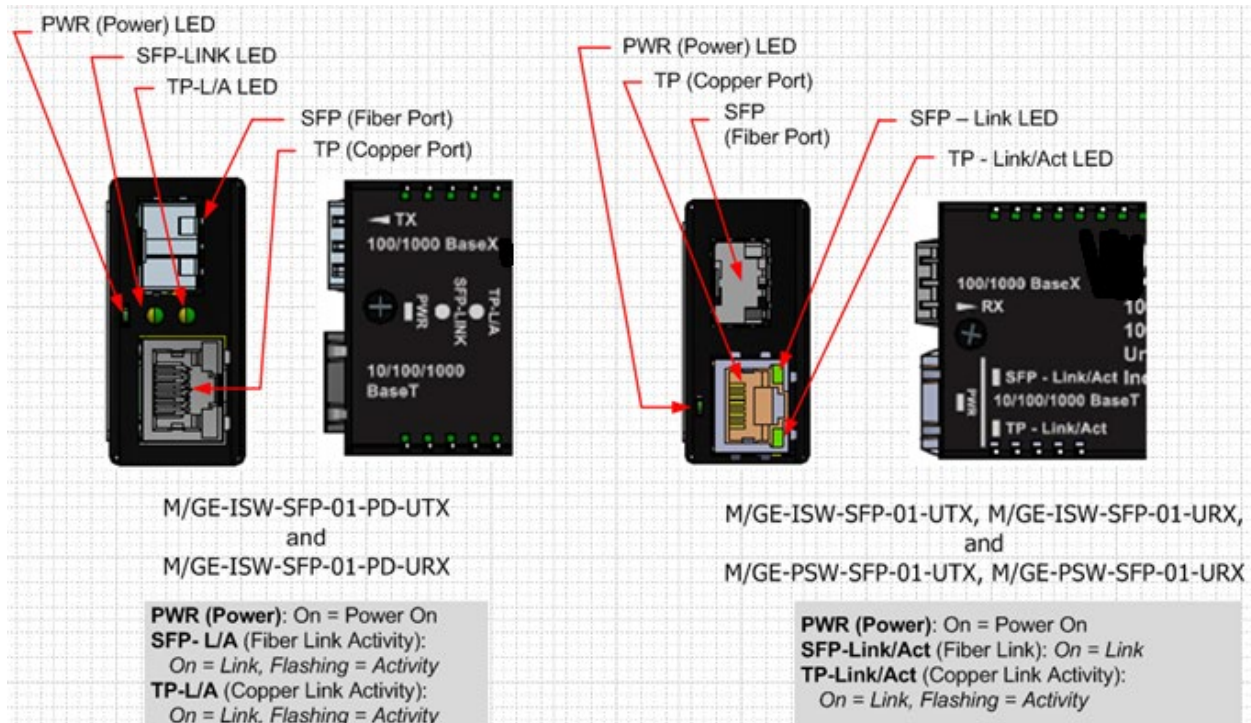

## Connect Fiber Cables

Full duplex (always ON) is on the fiber side only, therefore, the 512-Bit Rule does not apply. Cable lengths are constrained by the cable requirement.

1. Use a 1000Base-SX or -LX10 fiber cable with male, two-stranded TX to RX connectors at each end.
2. Connect the fiber cable to the M/GE-xSW-SFP-01-xx-UxX Series media converters as follows:
  - Connect the male TX cable connector to the female TX port.
  - Connect the male RX cable connector to the female RX port.
3. Connect the fiber cable to the other device (*media converter, hub, etc.*) as follows:
  - Connect the male TX cable connector to the female RX port.
  - Connect the male RX cable connector to the female TX port.

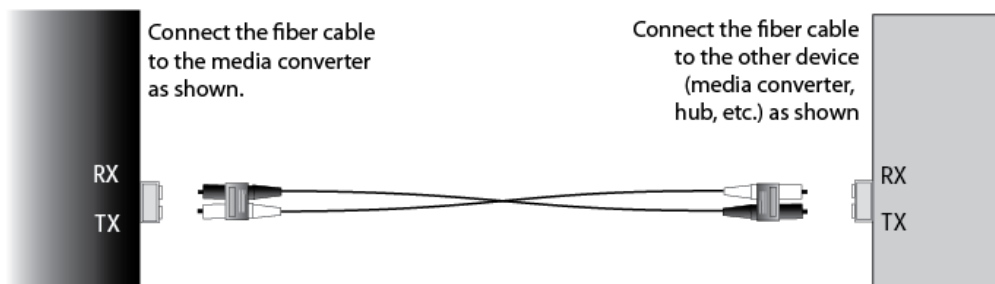

## Connecting Single-strand Fiber Cable

Single-strand fiber cable can only be used if the SFP module installed in the converter also supports bi-directional single strand fiber.

The uni-directional functions of these converters are controlled within the converter; therefore a duplex fiber cable can be used. Or, a simplex fiber cable can be used between the transmitting converter and the receiving converter. Additionally, bi-directional single-strand fiber can be used with these converters.

If using a simplex single-strand fiber cable, it is OK to leave open the unused Receive port or unused Transmit port on the converters; the converter will not try to transmit or receive data on these unused ports.

## Connect Twisted-pair Copper Cable

The AutoCross feature allows either MDI (*straight-through*) or MDI-X (*crossover*) cable connections to be configured automatically, according to network conditions.

- If half-duplex mode is used, refer to the 512-Bit Rule.
- If full-duplex mode is used, the 512-Bit Rule does not apply. The cable lengths are constrained by the cable requirements.

Perform these steps:

1. Locate a 10Base-T or 100Base-TX cable with RJ-45 connectors installed at both ends.
2. Connect the RJ-45 connector at one end of the cable to the RJ-45 port on the M/GE-xSW-SFP-01-xx-UxX Series media converter.
3. Connect the RJ-45 connector at the other end of the cable to the RJ-45 port on the other device (*switch, workstation, etc.*).

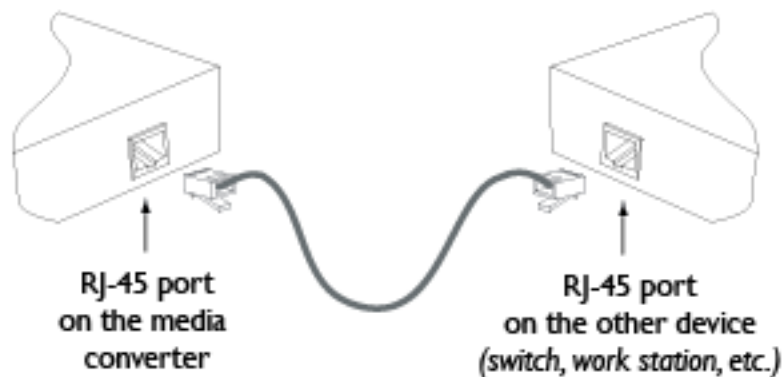

## Insert and Connect the SFP

These converters support dual speed 100/1000Mbps SFP modules.

Perform the steps below to install an SFP in the M/GE-PSW-SFP-01. Refer to the documentation that came with your SFP for specific requirements. See our [SFP webpage](#) for full details on our SFP products. See the [FOA Guide To Fiber Optics & Premises Cabling](#) for basic to advanced topics on fiber optics and premises cabling.

1. Remove the SFP transceiver module from its protective packaging. **Note:** Do not remove the optical bore dust plugs until directed to do so in a later procedure.
2. Check the slot orientation. Position the SFP device at the desired installation slot, with the label facing correctly.
3. Carefully slide the SFP device into the slot, aligning it with the internal installation guides.
4. Ensure that the SFP device is firmly seated against the internal mating connector.
5. Remove the dust plug from the connector. Save the dust plug for future use.
6. Connect the fiber cable to the fiber port connector of the SFP device. Make sure the SFP release latch is in the up (closed) position when you insert the cable connector into the SFP.
7. Attach the other end of the cable into the other device.

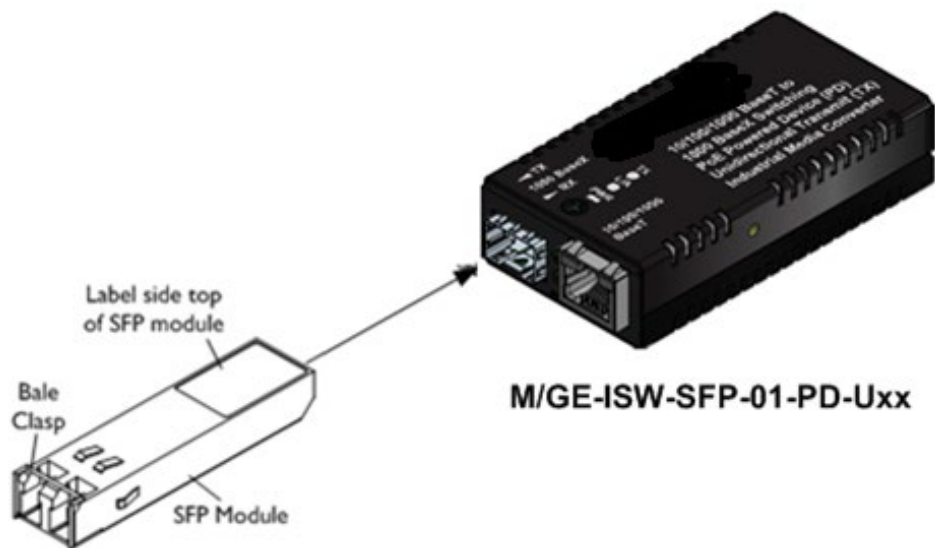

## Removing an SFP Module

**Caution:** Be careful when removing the SFP from a device. Some SFP transceiver module temperatures may exceed 160°F (70°C) and be too hot to touch with bare hands. **Note:** Do not remove and replace the SFP modules more often than necessary; excessive SFP removing and replacing can shorten the SFPs useful life.

1. Attach an ESD-preventive wrist strap to your wrist and to the ESD ground connector or a bare metal surface on your chassis.
2. For future reattachment of fiber-optic cables, note which connector plug is send (TX) and which is receive (RX).
3. Remove the SFP transceiver module:
  - a. If the SFP transceiver module has an actuator button latch, gently press the actuator button on the front of the SFP transceiver module until it clicks and the latch mechanism releases the SFP transceiver module from the socket connector. Grasp the actuator button between your thumb and index finger, and carefully pull the SFP transceiver module straight out of the module slot.
  - b. If the SFP transceiver module has a bail clasp latch, pull the latch out and down to eject the SFP transceiver module from the socket connector. If the bail clasp latch is obstructed and you cannot use your index finger to open it, use a small, flat-blade screwdriver or other long, narrow instrument to open the bail clasp latch. Grasp the SFP transceiver module between your thumb and index finger, and carefully remove it from the socket.
4. Replace the Dust Plug.
5. Place the removed SFP transceiver module in an antistatic bag or other protective package.

## Mounting Options

The M-GE-xSW-SFP-01-xx-UxX supports the following Mounting options. See [Related Manuals](#) on page 8 for links to Mounting option information.

- WMBM:** Wall Mount Bracket for Mini (for Enterprise Converters)
- M-MCR-01:** 18-Slot Powered Mini Chassis (for Enterprise Converters)
- DRBM:** DIN Rail Mount Bracket for Mini (for Enterprise Converters)
- RMBM:** Rack Mount Bracket for Mini, use with RMS19-SA4-02 and/or E-MCR-05

### Installing DIN Rail Clip

To install the DIN rail onto the media converter (parts are shown right):

1. Position the DIN rail clamp to the side of the media converter as shown below.

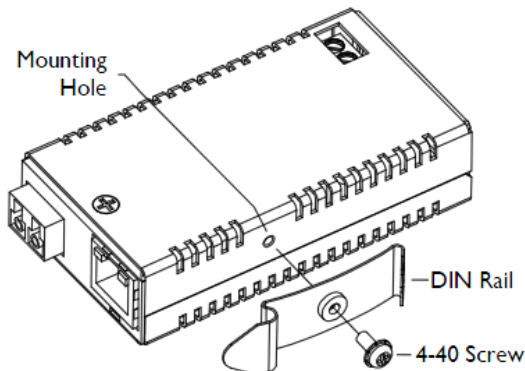
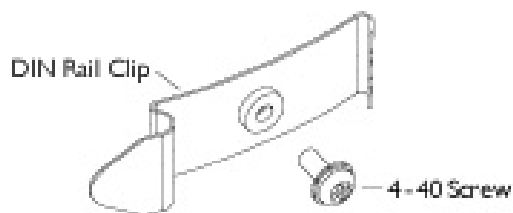
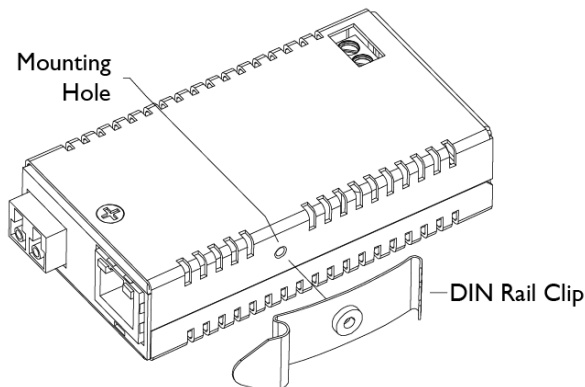

2. Position the 4-40 screw to attach the DIN rail to the media converter as shown above left.

3. Insert and tighten the 4-40 screw until the DIN rail clip appears as shown above right. When the DIN Rail Clip is attached, there should be no gap between the Clip and the media converter as shown below.

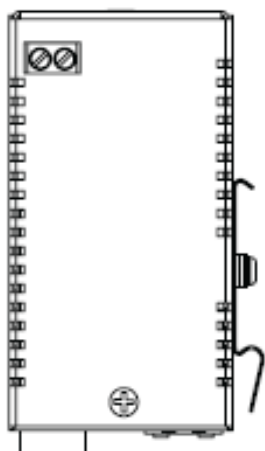

When the DIN Rail *Clip* is attached, there should be no "gap" between the *Clip* and media converter as shown.

## Connecting Power

The uni-directional converters are available in three power options

- DC input with a barrel connector for an external AC/DC power supply
- DC input with a terminal block
- PoE powered media converter

□ M/GE-PSW-SFP-01-UTX-NA and M/GE-PSW-SFP-01-URX-NA:

Power input: Barrel Connector. Supporting 4.5VDC to 14VDC.

External AC/DC power supply: Input: 100 to 240 VAC. Output: 12VDC.

□ M/GE-ISW-SFP-01-PD-UTX and M/GE-ISW-SFP-01-PD-URX:

Power input: RJ-45. Supporting IEEE802.3af PoE PD Standard.

□ M/GE-ISW-SFP-01-UTX and M/GE-ISW-SFP-01-URX:

Power input: Terminal Block. Supporting 12 – 48 VDC and 24 -36 VAC.

You can use your own power source, or you can use one of the three power supply options that Lantronix offers (see below).

## Power Supply Options

The M-GE-xSW-SFP-01-xx-UxX supports the following Power Supply options.

- **SPS-2460-SA** Power Supply, 24VDC to 60VDC input Stand-alone (for Enterprise Converters) (must be ordered separately)
- **SPS-UA12DHT** External AC/DC Desktop Power Supply, 12 VDC, 18W (for Hardened Non-PD Converters)
- **25165** Universal AC/DC Input DIN Rail Mountable +12 VDC Power Supply (for Hardened Non-PD Converters)

See [Related Manuals](#) on page 8 for power supply information.

### 3. Operation

#### Status LEDs

Use the status LEDs to monitor the M/GE-xSW-SFP-01-xx-UxX Series media converter operation in the network. LED descriptions are as follows:

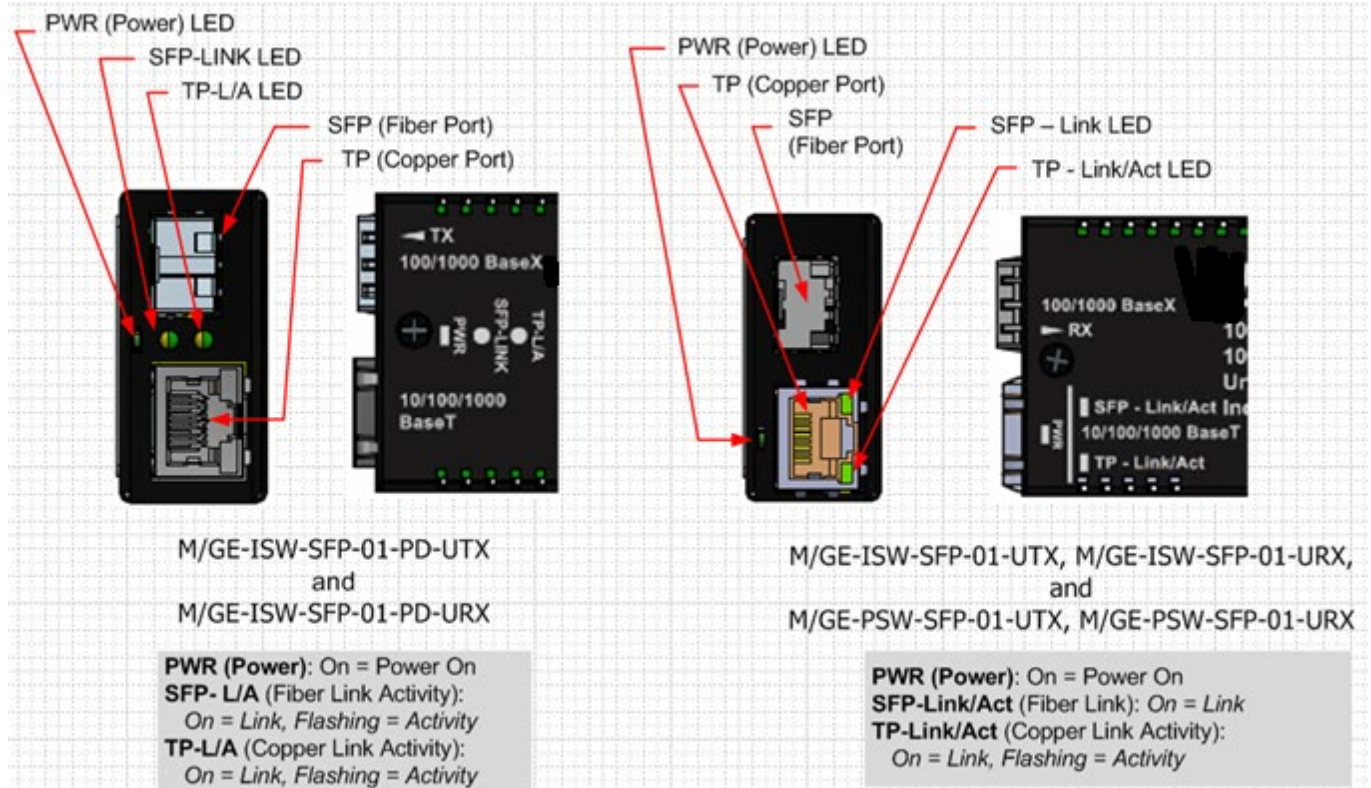

#### TP LED Blink Rate

The TP LED flash rate indicates the copper network speed:

Pulses/second	Blink Rate	Speed Indicated
12 pps	every 84 ms	1000Mbps (1Gbps)
6 pps	every 170 ms	100Mbps
3 pps	every 340 ms	10Mbps

If there is no activity on the TP Link when link is first established, the LED blinks 3 times at the rate above to indicate speed.



## SFP (Fiber) LED Operation

The SFP (Fiber) LED (the middle LED) indicates Link of 100Mbps or 1Gbps (see below).

LED operation of paired M/GE-ISW-SFP-01-PD-UTX and M/GE-ISW-SFP-01-PD-URX in different scenarios				
Scenario	TX Converter		RX Converter	
	TX LED	L/A LED	RX LED	L/A LED
All Links Down	ON	OFF	OFF	OFF
All Links up, but no data transfer	ON	ON	ON	ON
Data moving in the TX to RX converter direction	Flashing	ON	Flashing	Flashing
Data moving in the RX to TX converter direction	ON	ON	Flashing	Flashing

## Feature Descriptions

The M/GE-xSW-SFP-01-xx-UxX Series features include Congestion reduction, Auto-Negotiation, AutoCross, Automatic link restoration, Full-Duplex flow control, Half-Duplex flow control, Distance extension, and Rate conversion. These features are described below.

### Congestion Reduction

The M/GE-xSW-SFP-01-xx-UxX Series media converters do not forward collision signals or error packets from one collision domain to another, resulting in improvements in baseline network performance. In addition, the media converter filters packets destined for local devices, which reduces network congestion.

### Auto-Negotiation

The Auto-Negotiation feature is ON permanently for the M/GE-xSW-SFP-01-xx-UxX Series media converters. Auto-Negotiation allows the media converter to configure itself automatically to achieve the best possible mode of operation over a link. It broadcasts speed (10 Mb/s or 100 Mb/s) and duplex capabilities (full or half) to the other device and negotiates the best mode of operation. Auto-Negotiation allows quick and easy installation because the optimal link is established automatically.

In a scenario where an auto-negotiation device is linked to a non-negotiating device, the negotiating device via parallel detection recognizes the speed of that second device then establishes the best operating speed (10Mb/s or 100Mb/s) at half duplex.

### AutoCross

The AutoCross feature allows using either straight-through (MDI) or crossover (MDI-X) copper cables when connecting to 10Base-T or 100Base-TX devices. AutoCross determines the characteristics of the connection and automatically configures the device to link up, regardless of the copper cable configuration, MDI or MDI-X.

### Full-Duplex Flow Control

In a full-duplex network, maximum cable lengths are determined by the type of cables used—see page 1 (front cover) for M/GE-xSW-SFP-01-xx-UxX Series cable specifications. The 512-Bit Rule does not apply in a full-duplex network. **Note:** Full duplex is ON permanently for the fiber port only.

### Half-Duplex Flow Control (512-Bit Rule)

In a half-duplex network, the maximum cable lengths are determined by the roundtrip delay limitations of each Fast Ethernet collision domain. A collision domain is the longest path between any two terminal devices (e.g., a terminal, switch, or router.) The 512-Bit Rule determines the maximum length of cable permitted by calculating

the round-trip delay in bit-times (BT) of a particular collision domain. If the result is less than or equal to 512 BT, the path is good.

### Rate Conversion

The M/GE-xSW-SFP-01-xx-UxX Series media converters allow connection of 10Mb/s terminal devices on a 10Base-T legacy Ethernet copper network to 100Mb/s terminal devices on a 100Base-TX Fast Ethernet copper network and/or to 100Mb/s terminal devices on a 100Base-FX or -LX10 Fast Ethernet fiber network.

### Distance Extension

The M/GE-xSW-SFP-01-xx-UxX Series media converters can segment one (1) 10Base-T copper Ethernet and/or 100Base-TX copper Fast Ethernet, and one (1) 100Base-FX or -LX10 fiber Fast Ethernet collision domain:

- In a half-duplex Ethernet or Fast Ethernet environment, the M/GE-xSW-SFP-01-xx-UxX Series media converters extend network distances by segmenting collision domains so that the 512-Bit Rule applies separately to each collision domain.
- In a full-duplex Ethernet or Fast Ethernet environment, the M/GE-xSW-SFP-01-xx-UxX Series media converters extend network distances to the physical cable limitations imposed by the selected twisted-pair copper fiber cables.

### Fiber Cable and Optic Specifications

The fiber optic cable physical characteristics must meet or exceed IEEE 802.3ae specification.

#### Fiber cable

Bit Error Rate:	<10 <sup>-9</sup>
Single mode fiber ( <i>recommended</i> ):	9 μm
Multimode fiber ( <i>recommended</i> ):	62.5/125 μm
Multimode fiber ( <i>optional</i> ):	100/140, 85/140, 50/125 μm

#### Optics

Fiber Optic Transmitter Power:	depends on the SFP module used.
Fiber Optic Receiver Sensitivity:	depends on the SFP module used.
Link Budget:	depends on the SFP module used.

The fiber optic transmitters on this device meet Class I Laser safety requirements per IEC-825/CDRH standards and comply with 21 CFR1040.10 and 21CFR1040.11.

## Copper Cable

### Category 3: (Minimum requirement for 10 Mb/s operation)

Gauge	24 to 22 AWG
Attenuation	11.5 dB/100m @ 5-10 MHz
Maximum Cable Distance	100 meters

### Category 5: (Minimum requirement for 100 Mb/s operation)

Gauge	24 to 22 AWG
Attenuation	22.0 dB /100m @ 100 MHz
Maximum Cable Distance	100 meters

- Straight-through or crossover twisted-pair cable may be used.
- Shielded (STP) or unshielded (UTP) twisted-pair cable may be used.
- Pins 1&2 and 3&6 are the two active pairs in an Ethernet network.
- Use only dedicated wire pairs for the active pins: (e.g., blue/white & white/blue, orange/white & white/orange, etc.)
- Do not use flat or silver satin wire.

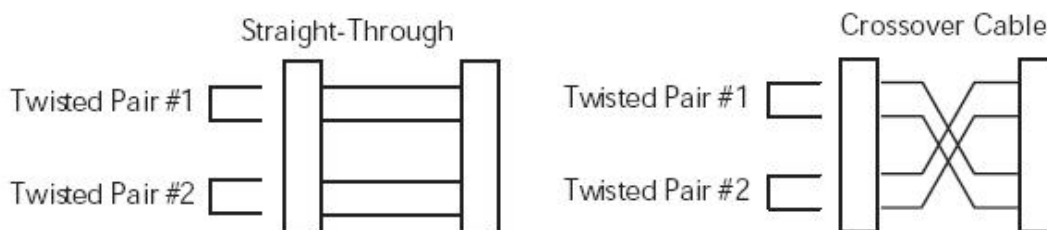

**CAUTION:** Copper based media ports, e.g., Twisted Pair (TP) Ethernet, USB, RS232, RS422, RS485, DS1, DS3, Video Coax, etc., are intended to be connected to intrabuilding (inside plant) link segments that are not subject to lightning transients or power faults. Copper-based media ports, e.g., Twisted Pair (TP) Ethernet, USB, RS232, RS422, RS485, DS1, DS3, Video Coax, etc., are NOT to be connected to interbuilding (outside plant) link segments that are subject to lightning transients or power faults. Failure to observe this caution could result in damage to equipment.

## 4. Related Information

### Specifications

Lantronix M/GE-xSW-SFP-01-xx-UxX converters are designed to meet these specifications:

Standards	IEEE 802.3, IEEE 802.3z, IEEE 802.3u, IEEE 802.3ab; IEEE 802.3af (PD Versions Only)
Status LEDs	Pwr (Power): On = Power FX-Link/Act (Fiber Link / Activity): On = Link, Flashing = Activity TX-Link/Act (Copper Link / Activity): On = Link, Flashing = Activity
Dimensions	Width: 1.8" [46 mm] x Depth: 3.3" [85 mm] x Height: 0.85" [22 mm]
Power Consumption	1.8 watts without the SFP module
Power Supply	External AC/DC required, 12 VDC, 0.5A
Power Input	4.5VDC to 14VDC (M/GE-PSW-SFP-01-UxX) 12 – 48 VDC or 24 – 36VAC (M/GE-ISW-SFP-01-UxX) IEEE 802.3af supplied through TP RJ-45 (M/GE-ISW-SFP-01-PD-UxX)
Environment	<b>M/GE-PSW-SFP-01-UxX:</b> Operating Temp.: 0°C to +50°C Humidity: 5% to 95% (non-condensing) Storage Temp.: -15°C to +65°C Altitude: 0 to 10,000 ft. <b>M/GE-ISW-SFP-01-xx-UxX:</b> Operating Temp.: -40°C to +75°C Humidity: 5% to 95% (non-condensing) Storage Temp.: -40°C to +85°C Altitude: 0 to 10,000 ft.
Weight	2 lbs. [0.9 kg]
Compliance	Safety: Wall Mount Power Supply, UL Listed, cUL Listed (Canada); FCC Class A, CISPR22 / EN55022 Class A, EN55034, CE Mark; TAA Compliant and NDAA Compliant
MTBF	Greater than 41,680 hours (MIL-HDBK-217F) Greater than 114,580 hours (Bellcore7 V5.0)
Warranty	Lifetime

**WARNING:** Visible and invisible laser radiation when open. Do not stare into the beam or view directly with optical instruments. Failure to observe this warning could result in an eye injury or blindness.

**WARNING:** Use of controls, adjustments, or the performance of procedures other than those specified herein could result in hazardous radiation exposure.

The information in this user's guide is subject to change. For the most current information, view the online user guide at <http://www.lantronix.com/>.

## Troubleshooting

If the media converter fails, isolate and correct the fault by answering the following questions and then taking the indicated action:

1. Is the PWR (power) LED lit?

NO

- Is the power adapter the proper type of voltage and cycle frequency for the AC outlet?
- Is the power adapter properly installed in the media converter and in the outlet?
- Contact Tech Support.

YES

- Proceed to step 2.

2. Is the RXC (copper link) LED lit?

NO

- Check the twisted-pair copper cables for proper connection.
- Contact Tech Support.

YES

- Proceed to step 3.

3. Is the LKF (fiber link) LED lit?

NO

- Check the fiber cables for proper connection.
- Verify that the TX and RX cables on the media converter are connected to the RX and TX ports, respectively, on the other device.
- If the media converter is connected to another M/GE-xSW-SFP-01-xx-UxX Series using fiber, verify the fiber cables and connection.
- Contact Tech Support.

YES

- Proceed to step 4.

4. Is the RXC (copper receive) LED flashing?

NO

- If there is activity on the 1000Base-T port, disconnect and reconnect the twisted-pair copper cable to restart the initialization process.
- Contact Tech Support.

YES

- Contact Tech Support.

5. Are the converters paired properly? See [Ordering Information](#) on page 5.

6. Is the proper copper cable installed and connected correctly? See [2. Installation](#) on page 9.

7. Is the proper fiber cable installed and connected correctly? See [Front Panel Copper and Fiber Ports](#) on page 9.

## Compliance Information

### Declaration of Conformity

Manufacture's Name: Lantronix, Inc.

Manufacture's Address: 48 Discovery, Suite 250, Irvine, California 92618

Declares that the products:

M/GE-PSW-SFP-01-UTX, M/GE-PSW-SFP-01-URX, M/GE-ISW-SFP-01-UTX, M/GE-ISW-SFP-01-URX, M/GE-ISW-SFP-01-PD-UTX, and M/GE-ISW-SFP-01-PD-URX

Conform to the following Product Regulations:

FCC Part 15 Class A, EN 55032:2012, EN 55024:2010

Directive 2014/30/EU

Low-Voltage Directive 2014/35/EU

IEC /EN 60950-1:2006+A2:2013

2011/65/EU EN 50581:2012

CISPR22 / EN55022 Class A, EN55034

With the technical construction on file at the above address, this product carries the CE Mark

I, the undersigned, hereby declare that the equipment specified above conforms to the above Directive(s) and Standard(s).

Place: Irvine, California

Date: April 27, 2022

Signature: *Fathi Hakam*

Full Name: Fathi Hakam

Position: Vice President of Engineering

### FCC Regulations

This equipment has been tested and found to comply with the limits for a Class A digital device, pursuant to Part 15 of the FCC rules. These limits are designed to provide reasonable protection against harmful interference when the equipment is operated in a commercial environment. This equipment generates, uses and can radiate radio frequency energy and, if not installed and used in accordance with the instruction manual, may cause harmful interference to radio communications.

Operation of this equipment in a residential area is likely to cause harmful interference, in which case the user will be required to correct the interference at the user's own expense.

### Canadian Regulations

This digital apparatus does not exceed the Class A limits for radio noise for digital apparatus set out on the radio interference regulations of the Canadian Department of Communications.

Le présent appareil numérique n'émet pas de bruits radioélectriques dépassant les limites applicables aux appareils numériques de la Class A prescrites dans le Règlement sur le brouillage radioélectrique édicté par le ministère des Communications du Canada.

## European Regulations

### Warning

This is a Class A product. In a domestic environment this product may cause radio interference in which case the user may be required to take adequate measures.

### Achtung !

Dieses ist ein Gerät der Funkstörgrenzwertklasse A. In Wohnbereichen können bei Betrieb dieses Gerätes Rundfunkstörungen auftreten. In diesem Fall ist der Benutzer für Gegenmaßnahmen verantwortlich.

### Attention !



Ceci est un produit de Classe A. Dans un environnement domestique, ce produit risque de créer des interférences radioélectriques, il appartiendra alors à l'utilisateur de prendre les mesures spécifiques appropriées.

In accordance with European Union Directive 2002/96/EC of the European Parliament and of the Council of 27 January 2003, Lantronix will accept post usage returns of this product for proper disposal. The contact information for this activity can be found in the 'Contact Us' portion of this document.



CAUTION: RJ connectors are NOT INTENDED FOR CONNECTION TO THE PUBLIC TELEPHONE NETWORK. Failure to observe this caution could result in damage to the public telephone network.

Der Anschluss dieses Gerätes an ein öffentliches Telekommunikationsnetz in den EGMitgliedstaaten verstösst gegen die jeweiligen einzelstaatlichen Gesetze zur Anwendung der Richtlinie 91/263/EWG zur Angleichung der Rechtsvorschriften der Mitgliedstaaten über Telekommunikationsendeinrichtungen einschliesslich der gegenseitigen Anerkennung ihrer Konformität.

**High Risk Activities Disclaimer:** Components, units, or third-party products used in the product described herein are NOT fault-tolerant and are NOT designed, manufactured, or intended for use as on-line control equipment in the following hazardous environments requiring fail-safe controls: the operation of Nuclear Facilities, Aircraft Navigation or Aircraft Communication Systems, Air Traffic Control, Life Support, or Weapons Systems ("High Risk Activities"). Lantronix and its supplier(s) specifically disclaim any expressed or implied warranty of fitness for such High Risk Activities.

**Notice:** Not Designed for Use in Life Support Equipment or Applications: These products are not designed for use in life support equipment or applications that would cause a life-threatening situation if any such product failed. Do not use this product in these types of equipment or applications.

**Trade Agreement Act (TAA) Compliant Products:** <https://www.lantronix.com/legal/rohs/taa-compliant-products/>

**NDAA, RoHS, REACH and WEEE Compliance:** <https://www.lantronix.com/legal/rohs/>

## **Electrical Safety Warnings**

### **Electrical Safety**

**IMPORTANT:** This equipment must be installed in accordance with safety precautions.

#### *Elektrische Sicherheit*

**WICHTIG:** Für die Installation dieses Gerätes ist die Einhaltung von Sicherheitsvorkehrungen erforderlich.

#### *Elektrisk sikkerhed*

**VIGTIG:** Dette udstyr skal installeres i overensstemmelse med sikkerhedsadvarslerne.

#### *Elektrische veiligheid*

**BELANGRIJK:** Dit apparaat moet in overeenstemming met de veiligheidsvoorschriften worden geïnstalleerd.

#### *Sécurité électrique*

**IMPORTANT:** Cet équipement doit être utilisé conformément aux instructions de sécurité.

#### *Sähköturvallisuus*

**TÄRKEÄÄ:** Tämä laite on asennettava turvaohjeiden mukaisesti.

#### *Sicurezza elettrica*

**IMPORTANTE:** questa apparecchiatura deve essere installata rispettando le norme di sicurezza.

#### *Elektrisk sikkerhet*

**VIKTIG:** Dette utstyret skal installeres i samsvar med sikkerhetsregler.

#### *Segurança eléctrica*

**IMPORTANTE:** Este equipamento tem que ser instalado segundo as medidas de precaução de segurança.

#### *Seguridad eléctrica*

**IMPORTANTE:** La instalación de este equipo deberá llevarse a cabo cumpliendo con las precauciones de seguridad.

#### *Elsäkerhet*

**OBS!** Alla nödvändiga försiktighetsåtgärder måste vidtas när denna utrustning används.



**Lantronix Corporate Headquarters**

48 Discovery, Suite 250  
Irvine, CA 92618, USA  
Toll Free: 800-526-8766  
Phone: 949-453-3990  
Fax: 949-453-3995

**Technical Support**

Online: <https://www.lantronix.com/technical-support/>

**Sales Offices**

For a current list of our domestic and international sales offices, go to the Lantronix web site at [www.lantronix.com/about/contact](http://www.lantronix.com/about/contact).