



## SM24DP4XA

### Managed Gigabit Ethernet Fiber Switch

(20) 100/1000Base-X SFP Slots + (4) 100/1000Base SFP/RJ-45 Combo Ports + (4) 1G/10GBase-X SFP+ Slots

## Install Guide

**Part Number 33769**  
**Revision F October 2024**

## Intellectual Property

© 2022-2024 Lantronix, Inc. All rights reserved. No part of the contents of this publication may be transmitted or reproduced in any form or by any means without the written permission of Lantronix.

*Lantronix* is a registered trademark of Lantronix, Inc. in the United States and other countries.

All other trademarks and trade names are the property of their respective holders.

Patented: <https://www.lantronix.com/legal/patents/>; additional patents pending.

## Warranty

For details on the Lantronix warranty policy, go to <http://www.lantronix.com/support/warranty>.

## Contacts

### Lantronix Corporate Headquarters

48 Discovery, Suite 250  
Irvine, CA 92618, USA  
Toll Free: 800-526-8766  
Phone: 949-453-3990  
Fax: 949-453-3995

### Technical Support

Online: <https://www.lantronix.com/technical-support/>

### Sales Offices

For a current list of our domestic and international sales offices, go to [www.lantronix.com/about/contact](http://www.lantronix.com/about/contact).

## Disclaimer

All information contained herein is provided "AS IS." Lantronix undertakes no obligation to update the information in this publication. Lantronix does not make, and specifically disclaims, all warranties of any kind (express, implied or otherwise) regarding title, non-infringement, fitness, quality, accuracy, completeness, usefulness, suitability or performance of the information provided herein. Lantronix shall have no liability whatsoever to any user for any damages, losses and causes of action (whether in contract or in tort or otherwise) in connection with the user's access or usage of any of the information or content contained herein. The information and specifications contained in this document are subject to change without notice.

## Revision History

Rev.	Date	Description of Changes
C	10/16/20	Update weight specs and add UL certification.
D	3/4/21	Update specs and change Power Supply from 25079 (EoL) to 25175.
E	7/28/21	Update Safety certification from EN60950 or IEC60950 to IEC62368-1/EN62368-1. Update DoC.
F	10/7/24	FW v7.20.0206: <ul style="list-style-type: none"> <li>◆ Add Perception and LPM support.</li> <li>◆ Update jumbo frame size specs.</li> <li>◆ Initial Lantronix rebrand.</li> <li>◆ Remove PS 25079 (EoL).</li> <li>◆ Update label information.</li> <li>◆ Fix Cable Diagnostics issue.</li> <li>◆ Update CLI setup information.</li> <li>◆ Add note on using Telnet vs. SSH.</li> <li>◆ Add UK and EU DoCs.</li> <li>◆ Remove Class ! Div 2 cert information.</li> </ul> See the Release Notes for details.

## Contents

<b>Safety Warnings and Cautions .....</b>	<b>4</b>
<b>Chapter 1 - Overview .....</b>	<b>5</b>
Key Features .....	5
Benefits .....	5
Ordering Information .....	6
Specifications .....	6
Software Features .....	7
Front Panel .....	17
LEDs .....	18
RST (Reset) button .....	20
Back Panel .....	20
Side Panel .....	20
Manual Overview .....	21
For More Information .....	21
<b>Chapter 2 – Installing the Switch .....</b>	<b>22</b>
Package Contents .....	22
Regional Versions of Power Cords .....	22
Safety Instructions for Rack Mount Installations .....	22
Mounting the Switch in a 19-inch Rack .....	23
Mounting the Switch on Desk or Shelf .....	23
Grounding the Switch .....	24
Installing SFP Modules .....	24
Connecting Network Devices .....	25
Twisted-Pair Devices .....	25
Cabling Guidelines .....	25
Connecting to PCs, Servers, Hubs, and Switches .....	25
AC/DC/DC Redundant Power .....	27
Connecting the AC Power Cord .....	27
Connecting to DC Power .....	28
Power Supply Specifications .....	30
25131 for 48VDC .....	30
Optional Power Supply 25175 .....	32
25175 Features .....	32
25175 Specifications .....	32
25175 Installation .....	34
<b>Chapter 3 - Initial Switch Setup .....</b>	<b>38</b>
Initial Switch Setup via Web Browser .....	38
Initial Switch Setup via CLI .....	39
<b>Chapter 4 - Troubleshooting .....</b>	<b>40</b>
Basic Troubleshooting .....	40
Troubleshooting Table .....	40
LED Troubleshooting .....	41
Device Label and Packaging Label Information .....	41
Record Device and System Information .....	42
<b>Chapter 5 - Regulatory and Safety Information .....</b>	<b>43</b>
Certifications .....	43
Compliance and Safety Statements .....	43
High Risk Activities Disclaimer .....	43

Accessibility Statement .....	43
CE EMC Test .....	44
FCC EMI Test.....	44
EU Declaration of Conformity.....	45
UK Declaration of Conformity.....	46
Cautions and Warnings.....	47
Electrical Safety Warnings .....	48

## Safety Warnings and Cautions

These products are not intended for use in life support products where failure of a product could reasonably be expected to result in death or personal injury. Anyone using this product in such an application without express written consent of an officer of Lantronix does so at their own risk and agrees to fully indemnify Lantronix for any damages that may result from such use or sale.



**Attention:** This product, like all electronic products, uses semiconductors that can be damaged by ESD (electrostatic discharge). Always observe appropriate precautions when handling.



**Note:** Emphasizes important information or calls your attention to related features or instructions.



**Caution:** Alerts you to a potential hazard that could cause loss of data or damage the system or equipment.



**Warning:** Alerts you to a potential hazard that could cause personal injury.

## Chapter 1 - Overview

The SM24DP4XA is a next generation Layer 2 managed switch with 128Gbps switching capacity. It provides up to (24) dual speed fiber slots and (4) 10Gig aggregation ports; it's an ideal switch for fiber aggregation applications.

The SM24DP4XA delivers 20 GbE SFP ports, 4 Combo GbE RJ45/SFP ports, 4 GbE/10G SFP+ ports, RJ45 Console port and OOB Management port with built-in AC and dual DC power support. The SM24DP4XA provides front panel access to all power, data, and management ports to facilitate desktop or rack-mount installations.

The SM24DP4XA is ideal for environments that require advanced features for granular control which is a must for easy network configuration and management where you need a successful installation for high-bandwidth VoIP, Gigabit-to-the-Desktop deployments, and converged voice and data networks.

### Key Features

- DMS (Device Management System) provides Graphical Monitoring (Topology, Floor, & Map views, Traffic Monitoring, & Troubleshooting (network diagnostic, protection, performance & link management)
- Device Management System: Graphic Monitoring, Mapping, Traffic Monitoring
- L2+ features provide better manageability, security, QoS, and performance
- Guest VLAN, Voice VLAN, Port based, tag-based and Protocol based VLANs
- 802.3az Energy Efficient Ethernet
- IPv6/ IPv4 Dual stack
- IEEE 802.3ah OAM and IEEE 802.1ag and Y.1731 CFM
- IEEE 1588v2 PTP
- L2/L3/L4 ACLs support MAC ACL, IP standard/extended ACL, 802.1p, Ethernet type
- ITU-T G.8031 Ethernet Linear Protection Switching (EPS)
- ITU-T G.8032 Ethernet Ring Protection Switching (ERPS)
- Ethernet Virtual Circuits (EVC) for EPL and EVPL services
- Spanning Tree protocol (STP, RSTP, MSTP) and Rapid Ring support
- NDAA Compliant and TAA Compliant
- PercepXion and LPM support
- Media Redundancy Protocol (MRP)
- AC/DC Dual Power Supply

### Benefits

**Exceptional Precision with IEEE 1588v2 (TC)** : The switch performs IEEE1588v2 with transparent clock capability, implementations in hardware, so there is no performance penalty on packet processing. The hardware architecture ensures low latency and high time accuracy – critical for delay-sensitive financial and mobile applications.

**Superior reliability through OAM and CFM for Service Assurance** : Service assurance is provided through a rich feature set of operations, administration, and maintenance (OAM) functionalities. It can simplify and facilitate the management of Ethernet networks, resulting in diminishing operational costs. The Ethernet access device also offers standards-based fault and performance management in adherence with Y.1731 PM and 802.1ag connectivity fault management (CFM) standards. These features contribute to significant reduction in operational

expenditures and allows for troubleshooting without expensive truck rolls.

## Ordering Information

SKU	Description
<b>SM24DP4XA</b>	Managed fiber switch, (20) 100/1000BASE-X + (4) 100/1000 SFP/RJ-45 Combo + (4) 1G/10G SFP+ with 19" Rack Mount ears included
<b>25131</b>	Industrial DIN rail mounted <a href="#">Power Supply</a> , 48VDC, 76.8Watts (option; order separately)
<b>25175</b>	Industrial DIN rail mounted <a href="#">Power Supply</a> . Input: 90 – 264VAC, 127 - 370VDC; Output: 24 - 48VDC, 5.0A, 120 Watts. Operating Temp: -20°C to +70°C. Option; order separately.
<b>SFPs</b>	See Lantronix <a href="#">SFP webpage</a> (option; order separately)

## Specifications

### Port Configuration

Total Ports	SFP (100M/1G)	Uplinks (100M/1G/10G)	Console	MGMT
28	20	4 SFP+ 4 RJ45/SFP Combo	RJ45	RJ45

### Hardware Performance

Forwarding Capacity	Switching Capacity	MAC Table	Jumbo Frames
95.232 Mpps	128 Gbps	32 K	1518-4776 bytes including FCS

### Environmental Range

Operating Temperature		Storage Temperature		Altitude	
Fahrenheit	Centigrade	Fahrenheit	Centigrade	Feet	Meters
-4 to +140°	-20 to +60°	-13 to +158°	-25 to +70°	< 10000	< 3000

### Dimension, Weight, Humidity

Dimension (WxHxD)		Weight (no packaging)		Operating Humidity
Millimeters	Inches	Kilograms	Pounds	
442 x 44 x 211	17.4 x 1.73 x 8.31	3.0	6.50	10% to 90% non-condensing

## Voltage and Frequency

Input Voltage and Frequency	
AC Voltage	Single 100-240 VAC
AC Frequency	50-60 Hz
DC Voltage	Dual +24/+48 VDC or -24V/-48V VDC

## Industry Standards

Industry Standards	
Standard	IEEE 802.3™, IEEE 802.3u, IEEE 802.3z, IEEE802.3ae, IEEE 802.3x, IEEE 802.3ad, IEEE 802.1D, IEEE 802.1w, IEEE802.1s IEEE 802.1Q, IEEE 802.1p, IEEE 802.1ad, IEEE 1588v2, IEEE802.3ah, IEEE802.1ag, ITU-T Y.1731, ITU-T G.8031, ITU-T G.8032

## MTBF

Model	MTBF at 25.00 deg.	MTBF at 75.00 deg.
	Environment GB, GC - Ground Benign, Controlled	Environment GB, GC - Ground Benign, Controlled
SM24DP4XA	120,914 Hrs.	27,500 Hrs.

## Software Features

Layer 2 Switching	
Spanning Tree Protocol (STP)	<ul style="list-style-type: none"> <li>Standard Spanning Tree 802.1d</li> <li>Rapid Spanning Tree (RSTP) 802.1w</li> <li>Multiple Spanning Tree (MSTP) 802.1s</li> </ul>
Trunking	Link Aggregation Control Protocol (LACP) IEEE 802.3ad <ul style="list-style-type: none"> <li>Up to 14 groups</li> <li>Up to 4 ports per group</li> </ul>
VLAN	Supports up to 4K VLANs simultaneously (out of 4096 VLAN IDs) <ul style="list-style-type: none"> <li>Port-based VLAN</li> <li>802.1Q tag-based VLAN</li> <li>MAC-based VLAN</li> <li>Management VLAN</li> <li>Private VLAN Edge (PVE)</li> <li>Q-in-Q (double tag) VLAN</li> <li>Voice VLAN</li> <li>GARP VLAN Registration Protocol (GVRP)</li> </ul>
DHCP Relay	<ul style="list-style-type: none"> <li>Relay of DHCP traffic to DHCP server in different VLAN.</li> <li>Works with DHCP Option 82</li> </ul>
IGMP v1/v2/v3 Snooping	Limits bandwidth-intensive multicast traffic to only the requesters. Supports 1024 multicast groups

IGMP Querier	Used to support a Layer 2 multicast domain of snooping switches in the absence of a multicast router
IGMP Proxy	IGMP snooping with proxy reporting or report suppression actively filters IGMP packets in order to reduce load on the multicast router
MLD v1/v2 Snooping	Delivers IPv6 multicast packets only to the required receivers
<b>Layer 3 Switching</b>	
IPv4 Static Routing	IPv4 Unicast: Static routing
IPv6 Static Routing	IPv6 Unicast: Static routing
<b>Security</b>	
Secure Shell (SSH)	SSH secures Telnet traffic in or out of the switch; SSH v1 and v2 are supported
Secure Sockets Layer	SSL encrypts HTTP traffic, allowing secure access to browser-based management GUI
IEEE 802.1X	<ul style="list-style-type: none"> <li>• IEEE802.1X: RADIUS authentication, authorization and accounting, MD5 hash, guest VLAN, single/multiple host mode and single/multiple sessions</li> <li>• Supports IGMP-RADIUS based 802.1X</li> <li>• Dynamic VLAN assignment</li> </ul>
Layer 2 Isolation Private VLAN Edge	PVE (protected ports) provides L2 isolation between clients in the same VLAN. Supports multiple uplinks
Port Security	Locks MAC addresses to ports, and limits the number of learned MAC address
IP Source Guard	Prevents illegal IP address from accessing to specific port in the switch
RADIUS/ TACACS+	Supports RADIUS and TACACS+ authentication. Switch as a client
Storm Control	Prevents traffic on a LAN from being disrupted by a broadcast, multicast, or unicast storm on a port
DHCP Snooping	Acts as a firewall between untrusted hosts and trusted DHCP servers
ACLs	Supports up to 512 entries. Drop or rate limitation based on: <ul style="list-style-type: none"> <li>• Source and destination MAC, VLAN ID or IP address, protocol, port,</li> <li>• Differentiated services code point (DSCP) / IP precedence</li> <li>• TCP/ UDP source and destination ports</li> <li>• 802.1p priority</li> <li>• Ethernet type</li> <li>• Internet Control Message Protocol (ICMP) packets</li> <li>• TCP flag</li> </ul>



Quality of Service (QoS)	
Hardware Queue	Supports 8 hardware queues
Scheduling	<ul style="list-style-type: none"> <li>• Strict priority and weighted round-robin (WRR)</li> <li>• Queue assignment based on DSCP and class of service</li> </ul>
Classification	<ul style="list-style-type: none"> <li>• Port based</li> <li>• 802.1p VLAN priority based</li> <li>• IPv4/IPv6 precedence / DSCP based</li> <li>• Differentiated Services (DiffServ)</li> <li>• Classification and re-marking ACLs</li> </ul>
Rate Limiting	<ul style="list-style-type: none"> <li>• Ingress policer</li> <li>• Egress shaping and rate control</li> <li>• Per port</li> </ul>
Management	
DHCP Server	Support DHCP server to assign IP to DHCP clients
Remote Monitoring (RMON)	Embedded RMON agent supports RMON groups 1,2,3,9 (history, statistics, alarms, and events) for enhanced traffic management, monitoring and analysis
Port Mirroring	Traffic on a port can be mirrored to another port for analysis with a network analyzer or RMON probe. Up to N-1 (where N is number of Switch ports) ports can be mirrored to single destination port. A single session is supported.
UPnP	The Universal Plug and Play Forum was formed to standardize discovery and control of networked devices. See the Open Connectivity Foundation <a href="#">webpage</a> .
Management	
IEEE 802.1ab (LLDP)	<ul style="list-style-type: none"> <li>• Used by network devices for advertising their identities, capabilities, and neighbors on an IEEE 802ab local area network.</li> <li>• Support LLDP-MED extensions</li> </ul>
Web GUI Interface	Built-in switch configuration utility for browser-based device configuration
CLI	For users to configure/manage switches in command line modes
Dual Image	Independent primary and secondary images for backup while upgrading
SNMP	SNMP version1, 2c and 3 with support for traps, and SNMP version 3 user-based security model (USM)
Firmware Upgrade	<ul style="list-style-type: none"> <li>• Web browser upgrade (HTTP/ HTTPs) and TFTP</li> <li>• Upgrade through console port as well</li> </ul>
NTP	Network Time Protocol (NTP) for clock synchronization between computer systems over packet-switched
Other Management	HTTP/HTTPs; SSH; DHCP Client/ DHCPv6 Client; Cable Diagnostics; Ping; Syslog; Telnet Client; IPv6 Management

PercepXion	PercepXion is Lantronix cloud-hosted or on-premise management platform that provides a single pane of glass for centralized management and automated monitoring of deployed Lantronix devices, along with real-time notifications, managed APIs and data dashboards. See the <a href="#">PercepXion</a> product page.
LPM	Lantronix Provisioning Manager is a software application that provisions, configures and updates Lantronix devices for local site installations and deployments. LPM discovery is enabled by default and is not configurable. See the <a href="#">LPM product page</a> .

<b>Ethernet OAM</b>	
IEEE 802.3ah Link OAM	Supports IEEE 802.3ah Ethernet OAM (Operations, Administration & Management)
IEEE 802.1ag & ITU-T Y.1731 Flow OAM	Supports IEEE 802.1ag Ethernet CFM (Connectivity Fault Management) Supports ITU-T Y.1731 Performance Monitoring
<b>Loop Protection</b>	
ITU-T G.8031	Supports ITU-T G.8031 Ethernet Linear Protection
ITU-T G.8032	Supports ITU-T G.8032 Ethernet Ring Protection Switching

## Power Consumption

### DC Power Consumption

Measure the DC power consumption after 60 minutes under full loading with wire speed forwarding.

#### DC Input: 24V

Status	Operating Interface	DC Current Consumption (A)	DC Voltage (V)	DC Power Consumption (W)
Non-loading	None	0.79	24	18.96
Full-load 5 minutes	20-Port 1G SFP 4-Port 1G RJ45 4-Port 10G SFP	1.65	24	39.60
Full-loading 60 minutes later	20-Port 1G SFP 4-Port 1G RJ45 4-Port 10G SFP	1.80	24	43.20

Status	Operating Interface	DC Current Consumption (A)	DC Voltage (V)	DC Power Consumption (W)
Full-load 5 minutes	22-Port 1G SFP 2-Port 1G RJ45 4-Port 10G SFP	1.66	24	39.84
Full-loading 60 minutes later	22-Port 1G SFP 2-Port 1G RJ45 4-Port 10G SFP	1.81	24	43.44

Status	Operating Interface	DC Current Consumption (A)	DC Voltage (V)	DC Power Consumption (W)
Full-load 5 minutes	24-Port 1G SFP 4-Port 10G SFP	1.57	24	37.68
Full-loading 60 minutes later	24-Port 1G SFP 4-Port 10G SFP	1.70	24	40.80

## DC Input: 48V

Status	Operation Interface	DC Current Consumption (A)	DC Voltage (V)	DC Power Consumption (W)
Non-loading	None	0.37	48	17.76
Full-load 5 minutes	20-Port 1G SFP 4-Port 1G RJ45 4-Port 10G SFP	0.82	48	39.36
Full-loading 60 minutes later	20-Port 1G SFP 4-Port 1G RJ45 4-Port 10G SFP	0.89	48	42.72

Status	Operation Interface	DC Current Consumption (A)	DC Voltage (V)	DC Power Consumption (W)
Full-load 5 minutes	22-Port 1G SFP 2-Port 1G RJ45 4-Port 10G SFP	0.75	48	36.00
Full-loading 60 minutes later	22-Port 1G SFP 2-Port 1G RJ45 4-Port 10G SFP	0.82	48	38.88

Status	Operation Interface	DC Current Consumption (A)	DC Voltage (V)	DC Power Consumption (W)
Full-load 5 minutes	24-Port 1G SFP 4-Port 10G SFP	0.81	48	38.88
Full-loading 60 minutes later	24-Port 1G SFP 4-Port 10G SFP	0.87	48	41.76

**AC Power Consumption**

\* Measure the AC power consumption after 30 minutes under full loading with wire speed forwarding.

**1. AC 100V Input**

Status	Test Status	AC Voltage (V)	AC Current Consumption (A)	Power Factor	Apparent Power (VA)	Real Power (W)
No Loading	None	100	0.37	0.54	37.00	19.98
Full-load 5 minutes	20-Port 1G SFP 4-Port 1G RJ45 4-Port 10G SFP	100	0.69	0.56	69.00	38.64
Full-loading 60 minutes later	20-Port 1G SFP 4-Port 1G RJ45 4-Port 10G SFP	100	0.74	0.56	74.00	41.44

Status	Test Status	AC Voltage (V)	AC Current Consumption (A)	Power Factor	Apparent Power (VA)	Real Power (W)
Full-load 5 minutes	22-Port 1G SFP 2-Port 1G RJ45 4-Port 10G SFP	100	0.69	0.56	69.00	38.64
Full-loading 60 minutes later	22-Port 1G SFP 2-Port 1G RJ45 4-Port 10G SFP	100	0.74	0.56	74.00	41.44

Status	Test Status	AC Voltage (V)	AC Current Consumption (A)	Power Factor	Apparent Power (VA)	Real Power (W)
Full-load 5 minutes	24-Port 1G SFP 4-Port 10G SFP	100	0.68	0.56	68.00	38.08
Full-loading 60 minutes later	24-Port 1G SFP 4-Port 10G SFP	100	0.73	0.56	73.00	40.88

**Note:** Apparent Power (VA) = AC Voltage x AC Current Consumption.

Real Power (W) = Apparent Power (VA) x Power Factor.

## 2. AC 110V Input

Status	Test Status	AC Voltage (V)	AC Current Consumption (A)	Power Factor	Apparent Power (VA)	Real Power (W)
No Loading	None	110	0.34	0.53	37.40	19.82
Full-load 5 minutes	20-Port 1G SFP 4-Port 1G RJ45 4-Port 10G SFP	110	0.63	0.54	69.30	37.42
Full-loading 60 minutes later	20-Port 1G SFP 4-Port 1G RJ45 4-Port 10G SFP	110	0.68	0.55	74.80	41.14

Status	Test Status	AC Voltage (V)	AC Current Consumption (A)	Power Factor	Apparent Power (VA)	Real Power (W)
Full-load 5 minutes	22-Port 1G SFP 2-Port 1G RJ45 4-Port 10G SFP	110	0.65	0.55	71.50	39.33
Full-loading 60 minutes later	22-Port 1G SFP 2-Port 1G RJ45 4-Port 10G SFP	110	0.69	0.55	75.90	41.75

Status	Test Status	AC Voltage (V)	AC Current Consumption (A)	Power Factor	Apparent Power (VA)	Real Power (W)
Full-load 5 minutes	24-Port 1G SFP 4-Port 10G SFP	110	0.63	0.55	69.30	38.12
Full-loading 60 minutes later	24-Port 1G SFP 4-Port 10G SFP	110	0.68	0.55	74.80	41.14

**Note:** Apparent Power (VA) = AC Voltage x AC Current Consumption.

Real Power (W) = Apparent Power (VA) x Power Factor.

### 3. AC 220V Input

Status	Test Status	AC Voltage (V)	AC Current Consumption (A)	Power Factor	Apparent Power (VA)	Real Power (W)
No Loading	None	220	0.20	0.45	44.00	19.80
Full-load 5 minutes	20-Port 1G SFP 4-Port 1G RJ45 4-Port 10G SFP	220	0.37	0.46	81.40	37.44
Full-loading 60 minutes later	20-Port 1G SFP 4-Port 1G RJ45 4-Port 10G SFP	220	0.41	0.46	90.20	41.49

Status	Test Status	AC Voltage (V)	AC Current Consumption (A)	Power Factor	Apparent Power (VA)	Real Power (W)
Full-load 5 minutes	22-Port 1G SFP 2-Port 1G RJ45 4-Port 10G SFP	220	0.38	0.46	83.60	38.46
Full-loading 60 minutes later	22-Port 1G SFP 2-Port 1G RJ45 4-Port 10G SFP	220	0.41	0.46	90.20	41.49

Status	Test Status	AC Voltage (V)	AC Current Consumption (A)	Power Factor	Apparent Power (VA)	Real Power (W)
Full-load 5 minutes	24-Port 1G SFP 4-Port 10G SFP	220	0.38	0.46	83.60	38.46
Full-loading 60 minutes later	24-Port 1G SFP 4-Port 10G SFP	220	0.41	0.46	90.20	41.49

**Note:** Apparent Power (VA) = AC Voltage x AC Current Consumption  
 Real Power (W) = Apparent Power (VA) x Power Factor

## 4. AC 240V Input

Status	Test Status	AC Voltage (V)	AC Current Consumption (A)	Power Factor	Apparent Power (VA)	Real Power (W)
No Loading	None	240	0.19	0.44	45.60	20.06
Full-load 5 minutes	20-Port 1G SFP 4-Port 1G RJ45 4-Port 10G SFP	240	0.36	0.45	86.40	38.88
Full-loading 60 minutes later	20-Port 1G SFP 4-Port 1G RJ45 4-Port 10G SFP	240	0.39	0.45	93.60	42.12

Status	Test Status	AC Voltage (V)	AC Current Consumption (A)	Power Factor	Apparent Power (VA)	Real Power (W)
Full-load 5 minutes	22-Port 1G SFP 2-Port 1G RJ45 4-Port 10G SFP	240	0.36	0.45	86.40	38.88
Full-loading 60 minutes later	22-Port 1G SFP 2-Port 1G RJ45 4-Port 10G SFP	240	0.39	0.45	93.60	42.12

Status	Test Status	AC Voltage (V)	AC Current Consumption (A)	Power Factor	Apparent Power (VA)	Real Power (W)
Full-load 5 minutes	24-Port 1G SFP 4-Port 10G SFP	240	0.35	0.45	84.00	37.80
Full-loading 60 minutes later	24-Port 1G SFP 4-Port 10G SFP	240	0.38	0.45	91.20	41.04

**Note:** Apparent Power (VA) = AC Voltage x AC Current Consumption.  
Real Power (W) = Apparent Power (VA) x Power Factor.



## Front Panel

The SM24DP4XA front panel provides the ports, LEDs, buttons, and power inputs as shown and described below.

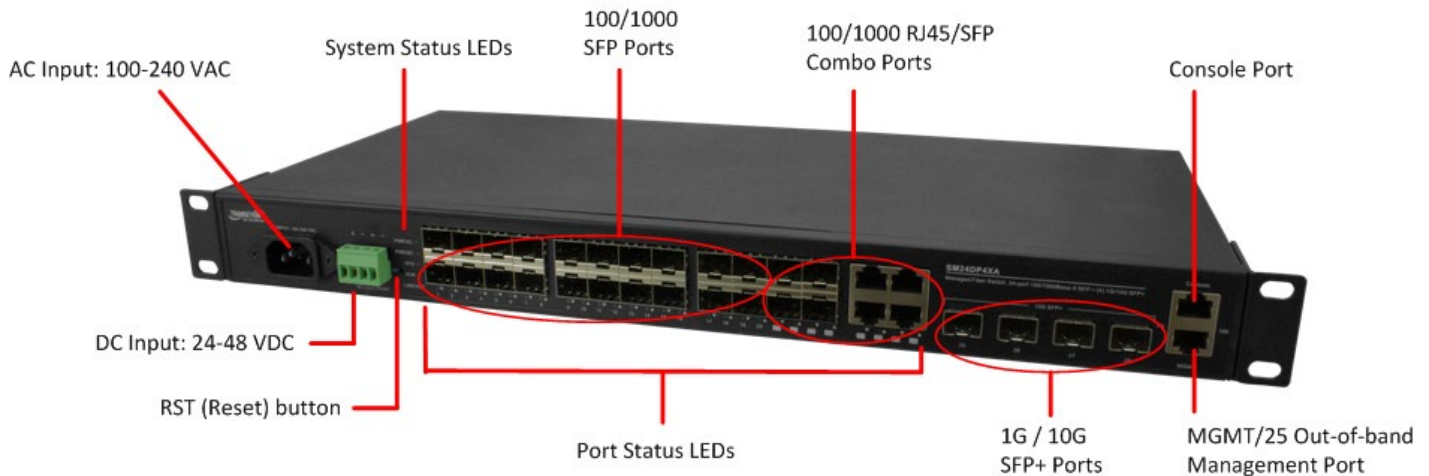

**Connectors:** Provides 1 Console Port, 1 Management port, 20 100/1000 SFP slots, 4 100/1000 SFP/RJ-45 Combo, and 4 1G/10G SFP+ slots.

**Console port:** 1 RJ-45 Console port to connect to a PC or terminal for Command Line Interface (CLI) command entry (e.g., a PC running Hyper Terminal, Tera Term, etc.). See [Initial Switch Configuration via CLI](#) on page 39.

**MGMT/25 port:** Dedicated out-of-band Management Port. Provides 1 RJ-45 Console port to connect to a PC's Ethernet port to run the Web UI. See [Initial Switch Configuration via Web Browser](#) on page 38.

**AC Input:** 100-240 VAC: Connects the Power Cord. See [Regional Versions of Power Cords](#) on page 22. See [Connecting the AC Power Cord](#) on page 26.

**DC Input** 24-48 V: Connects to DC Power. See [Connecting to DC](#) on page 27.

**RST (Reset) button:** see [RST \(Reset\) button](#) on page 20.



## LEDs

The front panel LEDs provide with switch status checking and monitoring as shown and described below.

**AC/DC Power LED:** Indicates if the switch is powered up correctly.

**SYS (System) Status LED :** Indicates if the system is ready.

**Port Status LEDs :** Indicate the current status of each port.

**ALM LED :** Indicates if the system is operating normally.

**LINK/ACT LED :** Port Status LEDs indicate if copper port is enabled, linked to a connected device, and connection speed.

**Table 1: Power LED**

LED	Color	State	Description
AC Power	Green	On	The switch is powered ON correctly.
		Off	The switch is not receiving power from power1.
DC Power	Green	On	The switch is powered ON correctly.
		Off	The switch is not receiving power from power2.

**Table 2: System LED**

LED	Color	State	Description
System	Green	On	The switch is ready and running ok.
		Off	The switch is not ready or failed.
		Blinking	The switch is booting.

**Table 3: Alarm LED**

LED	Color	State	Description
Alarm	Red	On	An abnormal state, such as temperature, voltage or fan speed, has been detected in the switch.
		Off	The system is normal

**Table 4: Port Status LEDs**

LED	Color	State	Description
RJ45 Ports	Green	On	The port is enabled and established a link to connected device, and the connection speed is 1000Mbps.
	Green	Blinking	The port is transmitting/receiving packets, and connection speed is 1000Mbps.
	Amber	On	The port is enabled and established a link to connected device, and the connection speed is 10/100Mbps.
	Amber	Blinking	The port is transmitting/receiving packets, and the connection speed is 10/100Mbps.
	--	Off	The port has no active network cable connected, or it is not established a link to connected device. Otherwise, the port may have been disabled through the switch user interface.
SFP Ports	Green	On	The port is enabled and established a link to connected device, and the connection speed is 1000Mbps.
	Green	Blinking	The port is transmitting/receiving packets, and connection speed is 1000Mbps.
	Amber	On	The port is enabled and established a link to connected device, and the connection speed is 100Mbps.
	Amber	Blinking	The port is transmitting/receiving packets, and the connection speed is 100Mbps.
	--	Off	The port has no active network cable connected, or it is not established a link to connected device. Otherwise, the port may have been disabled through the switch user interface.
SFP+ Ports	Blue	On	The port is enabled and established a link to connected device, and the connection speed is 10Gbps.
	Blue	Blinking	The port is transmitting/receiving packets, and the connection speed is 10Gbps.
	Green	On	The port is enabled and established a link to connected device, and the connection speed is 1Gbps.
	Green	Blinking	The port is transmitting/receiving packets, and connection speed is 1Gbps.
	--	Off	The port has no active network cable connected, or it is not established a link to connected device. Otherwise, the port may have been disabled through the switch user interface.

## RST (Reset) button

By pressing the front panel RST (Reset) button for certain period of time, you can:



- Reset the Switch** : To reboot and get the switch back to the previous configuration settings saved.
- Restore the Switch to Factory Defaults** : To restore the original factory default settings back to the switch.

**Note:** Based on the table below, you can determine which task is being performed by reading the LED behaviors while pressing the Reset button. Once the LED behaviors are correctly displayed, just release the button.

**Table 5: RST (Reset) Button Descriptions**

Task to perform	Press the RST button for	SYS LED Behavior	Port Status LED Behavior
Reset the Switch	2 ~ 7 seconds	Blinking Green	ALL LEDs OFF
Restore to Defaults	7 ~ 12 seconds	Blinking Green	ALL LEDs stay ON

## Back Panel

The SM24DP4XA back panel provides the Ground Screw as shown below.



## Side Panel

The SM24DP4XA left side panel has two fans. Make sure that the left side panel fan vents are not blocked after installation.

## Manual Overview

This manual describes how to install, initially configure, and troubleshoot the switch, including how to:

- Install the switch,
- Check switch status by reading the LED behavior,
- Reset the switch or restore the switch to factory defaults,
- Use a Web browser or the CLI to initially configure the switch, and
- Troubleshoot the switch.

Note that this manual provides links to third party web sites for which Lantronix is not responsible.

## For More Information

A printed Quick Start Guide is shipped with each device.

For Lantronix Documentation, Firmware, App Notes, etc. go to <https://www.lantronix.com/technical-support/>.

Note that this manual provides links to third party web sites for which Lantronix is not responsible.

Visit the Lantronix Web site at [www.lantronix.com/support/documentation](http://www.lantronix.com/support/documentation) for the latest documentation.

Related manuals include:

- SM24DP4XA Quick Start Guide, 33768
- SM24DP4XA Web User Guide, 33770
- SM24DP4XA CLI Reference, 33771
- SM24DP4XA API User Guide, 33836
- Release Notes (version specific)

## Chapter 2 – Installing the Switch

### Package Contents

Check the package contents to make sure you have received the following items. Contact your sales representative if any item is damaged or missing. Please save the packaging for possible future use.

- One SM24DP4XA switch
- One DB-9 to RJ45 Cable
- Four adhesive-backed rubber feet
- One printed Quick Start Guide
- One documentation postcard
- Rack Mount Brackets
- AC Power cord (option)

### Regional Versions of Power Cords

**Power Cord Included:** to order the corresponding country-specific power cord, add the extension from the list below to the end of the SKU: -NA = North America, -LA = Latin America, -EU = Europe, -UK = United Kingdom, -SA = South Africa, -JP = Japan, -OZ = Australia, -BR = Brazil.

### Safety Instructions for Rack Mount Installations

The instructions below (or similar) are intended for rackmount installation environments:

1. **Elevated Operating Ambient:** if installed in a closed or multi-unit rack assembly, the operating ambient temperature of the rack environment may exceed room ambient. Install the equipment in an environment compatible with the maximum ambient temperature (T<sub>ma</sub>) specified.
2. **Reduced Air Flow:** install the equipment in a rack so that the amount of air flow required for safe operation is not compromised.
3. **Mechanical Loading:** Mount the equipment in the rack so that a hazardous condition does not occur due to uneven mechanical loading (weight distribution/rack balance).
4. **Circuit Overloading:** give consideration to the connection of the equipment to the supply circuit and the effect that overloading of the circuits might have on overcurrent protection and supply wiring. Consider all equipment nameplate ratings when addressing this concern.
5. **Reliable Earthing:** maintain reliable earthing of rack-mounted equipment; pay particular attention to supply connections other than direct connections to the branch circuit (e.g., use of power strips).

**Note:** The SM24DP4XA left side panel has two fans. Do not block the left side panel fan vents during installation.

## Mounting the Switch in a 19-inch Rack

1. Attach the mounting brackets to both sides of the chassis. Insert screws and tighten with a screwdriver to secure the brackets.

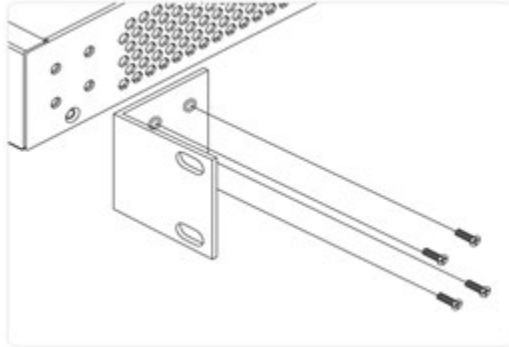

2. Place the switch on a rack shelf in the rack. Push it in until the oval holes in the brackets align with the mounting holes in the rack posts.

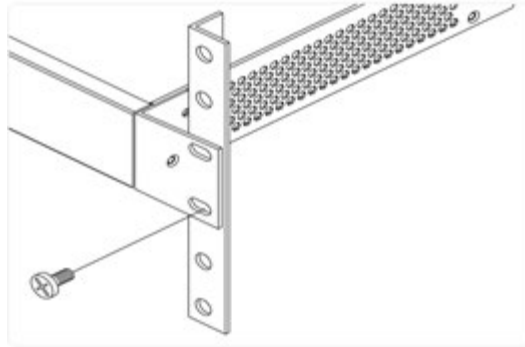

3. Attach the brackets to the posts. Insert screws and tighten them.

## Mounting the Switch on Desk or Shelf

1. Verify that the surface is sturdy and reliably grounded.
2. Attach the four adhesive rubber feet to the bottom of the switch.

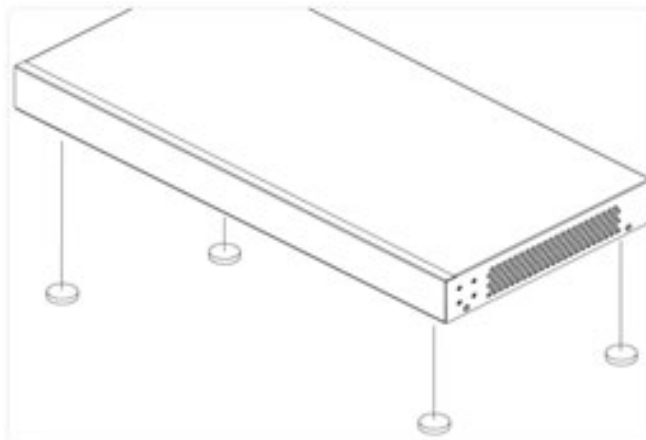

## Grounding the Switch

The SM24DP4XA back panel provides the Ground Screw as shown below.

**ATTENTION:** This case must be earth grounded. No DC input may be earth grounded.

Use Isolated Power Supply.



## Installing SFP Modules

You can install or remove a mini-GBIC SFP/SFP+ module from an SFP/SFP+ port without having to power off the switch.

**Note:** The SFP ports should use UL Listed Optional Transceiver product, Rated 3.3Vdc, Laser Class 1. See the SFP manual for important cautions, warnings, and instructions. See the Lantronix [SFP page](#) for our full range of Optical Devices.

1. Verify the SFP orientation (label up or down) and insert the SFP module into the SFP port. The SFP is inserted with the label up on the four 10G SFP+ ports. For the 24 1G SFP ports, the SFP is inserted with the label up on the top row of ports and with the label down on the bottom row of ports.

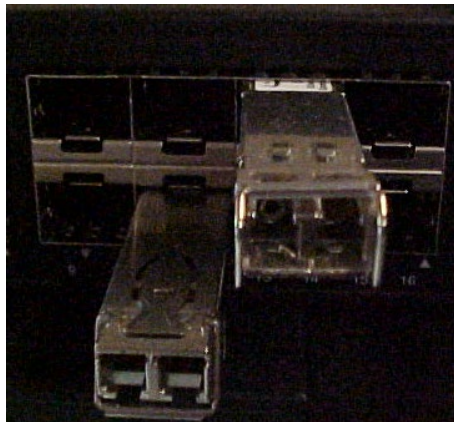

2. Press firmly to ensure that the module seats into the connector.

**Note:** Use an attenuator if the lengths will be less than half the maximum range of your particular optics.



## Connecting Network Devices

The switch is designed to be connected to 10, 100 or 1000Mbps network cards in PCs and servers, as well as to other switches and hubs. It may also be connected to remote devices using optional SFP transceivers.

### Twisted-Pair Devices

Each device requires an unshielded twisted-pair (UTP) cable with RJ-45 connectors at both ends. Use Category 5, 5e, or 6 cable for 1000BASE-T connections, Category 5 or better for 100BASE-TX connections.

### Cabling Guidelines

The RJ-45 ports on the switch that support automatic MDI/MDI-X pin-out configuration, so you can use standard straight-through twisted-pair cables to connect to any other network device (PCs, servers, switches, routers, or hubs).

**CAUTION:** Do not plug a phone jack connector into an RJ-45 port. This will damage the switch. Use only twisted-pair cables with RJ-45 connectors that conform to FCC standards.

### Connecting to PCs, Servers, Hubs, and Switches

1. Attach one end of a twisted-pair cable segment to the device's RJ-45 connector.

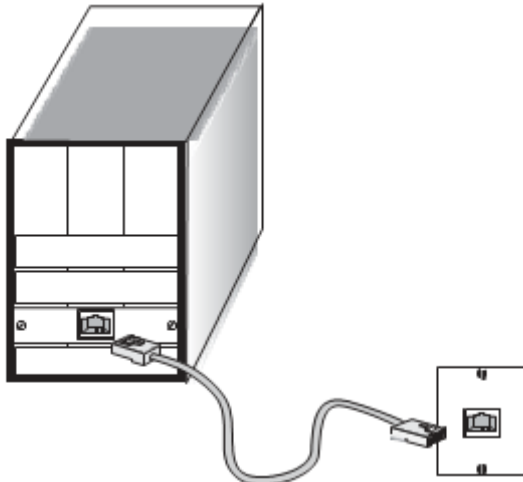

2. If the device is a network card and the switch is in the wiring closet, attach the other end of the cable segment to a modular wall outlet that is connected to the wiring closet. See the section "Network Wiring Connections". Otherwise, attach the other end to an available port on the switch.
3. Make sure each twisted pair cable does not exceed 100 meters (328 ft.) in length.
4. As each connection is made, the Link LED corresponding to each port will light green (1000 Mbps) or amber (100 Mbps) to indicate that the connection is valid.

## Network Wiring Connections

The punch-down block is an integral part of many of the newer equipment racks. It is a part of the patch panel. Instructions for making connections in the wiring closet with this type of equipment follows.

1. Attach one end of a patch cable to an available port on the switch, and the other end to the patch panel.
2. If not already in place, attach one end of a cable segment to the back of the patch panel where the punch-down block is located, and the other end to a modular wall outlet.
3. Label the cables to simplify future troubleshooting.

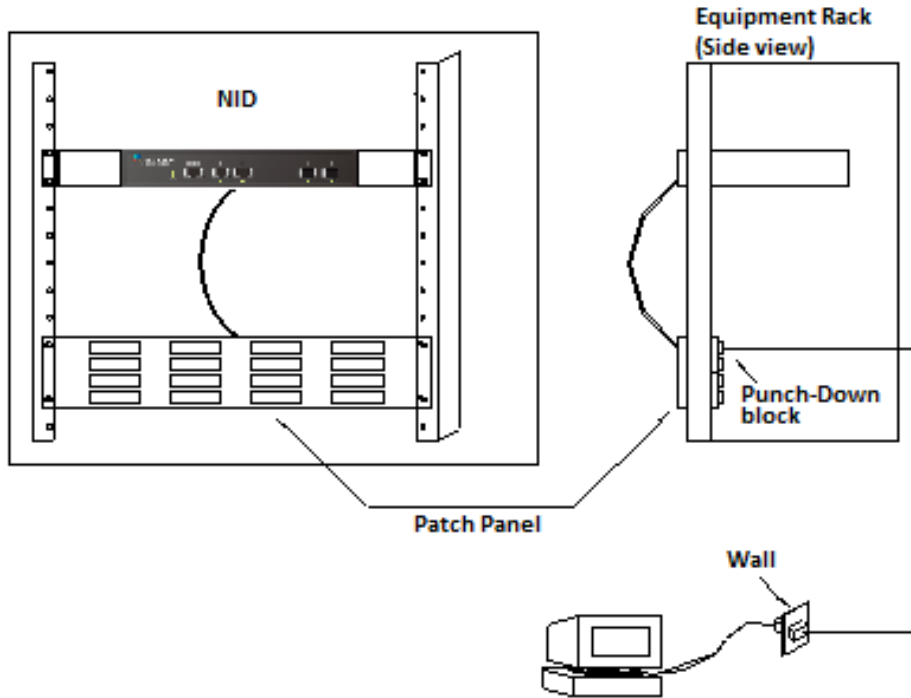

## AC/DC/DC Redundant Power

The three power inputs (AC/DC/DC) are redundant but in active/standby mode. There is failover between the three inputs but selecting primary and secondary is not supported.

To select the primary and secondary inputs:

1. Between AC and DC : Both AC and DC will convert the input power to 12VDC output to the PCB; the design will compare the voltage of 12VDC output and select the higher voltage as the primary power. If the primary power fails, the secondary will take over.
2. Between two DC inputs: The DC input with higher voltage is the primary input, the other is the secondary input.

Selecting the priority between AC and DC is not supported, but you can select between two DC inputs by adjusting the DC output. See [Power Supply Specifications](#) on page 30.

## Connecting the AC Power Cord

**Power Connection: Warning:** Connect the power supply to the switch first, and then connect the power supply to power. Otherwise catastrophic product failure may occur.

1. Verify that power is off to the DC circuit that you are going to attach to the switch DC-input connector. This can be either of the two power supplies (AC-input or DC-input) or site source DC.
2. As an added precaution, place an appropriate safety flag and lockout device at the source power circuit breaker, or place a piece of adhesive tape over the circuit breaker handle to prevent accidental power restoration while you are working on the circuit.

**Power Disconnection:** To disconnect power from the switch after a successfully boot: **1.** Turn off power to the switch. **2.** Disconnect the cables.

You can order one AC Power cord as a separate option.

1. Connect the AC power cord to the AC power receptacle of switch.
2. Connect the other end of the AC power cord to the AC power outlet.
3. Check the **SYS** LED. If it is lit, the power connection is correct.

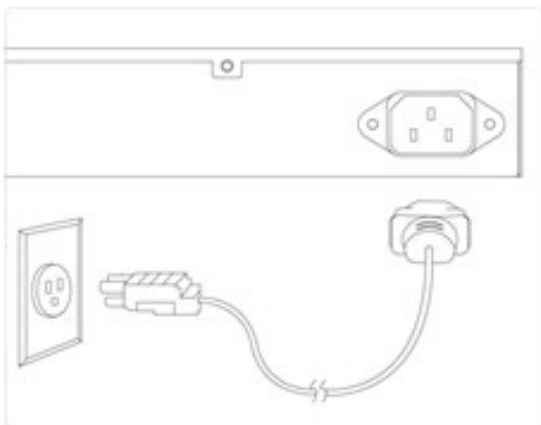

## Connecting to DC Power

The SM24DP4XA supports dual 24/48 VDC or -24/-48 VDC inputs. The power source must be powered off when connecting and disconnecting this product.

1. Insert the negative or positive voltage DC power source wires into the DC INPUT terminals, respectively as shown below:

### Negative Voltage DC Power Source

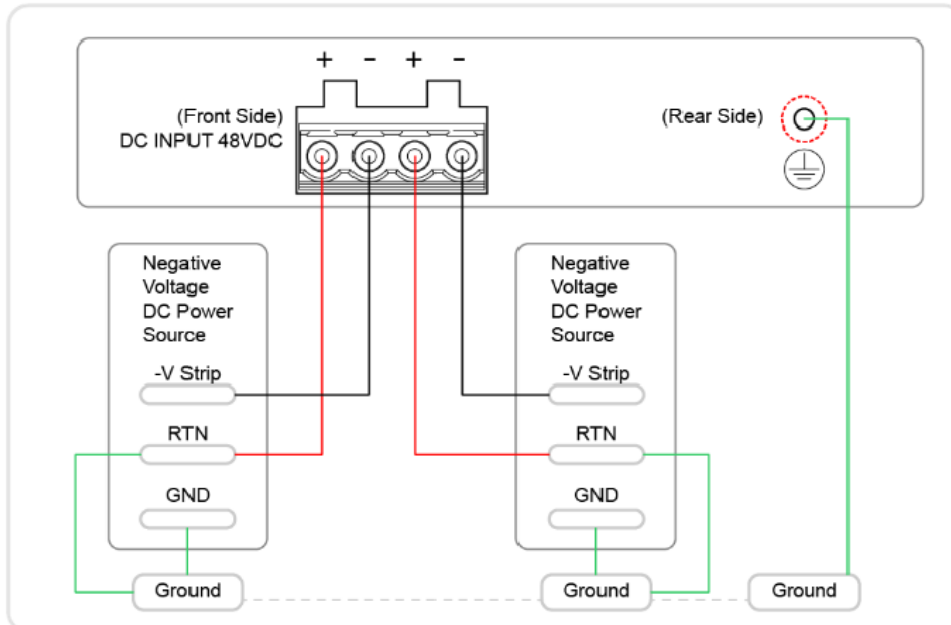

### Positive Voltage DC Power Source

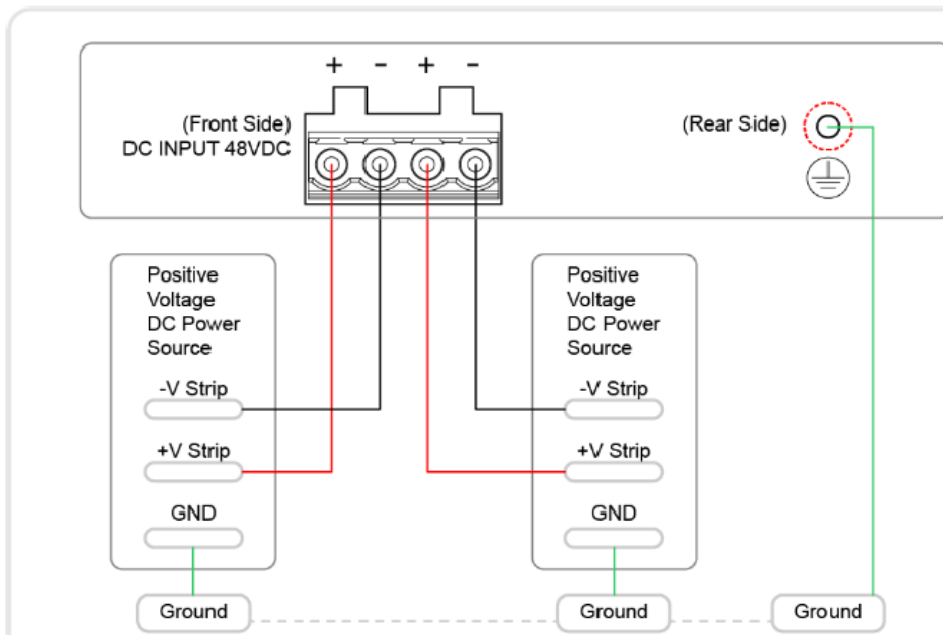

2. To keep the DC wires from pulling loose, use a small flat-blade screwdriver to tighten the wire-clamp screws on the front of the terminal block connector.

3. Insert the terminal block connector prongs into the terminal block receptor.
4. Turn the power source On.
5. Check the SYS LED. If it is ON, the power connection is correct.

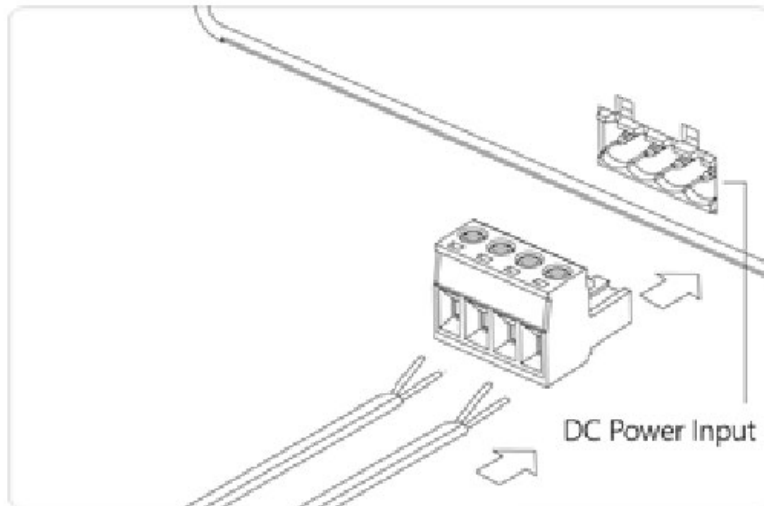

**Connecting DC Power Input**

## Power Supply Specifications

Two DC Power Supply options are available which must be ordered separately.

### 25131 for 48VDC

25131 Industrial DIN rail mounted power supply, 48VDC, 76.8 Watts

See <https://www.lantronix.com/products/25131-2/>.

#### 25131 Features

- Auto-Negotiation
- Variable AC input range
- Protected against Overload, Over Voltage, and Over Temperature
- Convection air cooling
- DIN Rail mountable
- UL 508 approved
- RoHS compliant
- MTBF 481.9Khrs
- Adjust output voltage with the front panel +V ADJ adjustment screw
- Verify the DC Out by observing the DC OK front panel LED

#### 25131 Output

- Output Voltage 48VDC
- Current Rating 1.6A
- Power Rating 76.8 Watts
- Ripple & Noise Max 120mVp-p
- Voltage Range 48~55VDC
- Voltage Tolerance  $\pm 1.0\%$
- Line Regulation  $\pm 0.5\%$
- Load Regulation  $\pm 1.0\%$
- Setup, Rise Time 3000ms, 60ms
- Hold Up Time 20ms/115VAC

#### 25131 Input

- Voltage Range Switch Selectable: 88~264VAC, 124~370VDC
- Frequency Range 47~63Hz
- Efficiency 90%
- AC Current (Typical) 1.4A@115VAC, .85A@230VAC
- Inrush Current (Cold) 30A@115VAC, 50A@230VAC
- Leakage Current <1mA@240VAC

25131 Protection: Overload 110~150%; Overvoltage 56~65.8V

25131 Dimensions: Width: 1.26" [32 mm] Depth: 4.02" [102 mm] Height: 4.93" [125.2 mm]

25131 Environment: Operating Temp: -30°C to +70°C. Storage: -40°C to +85°C. Humidity: 20% to 95% (non-condensing)

25131 Weight: 1.12 lbs. [0.51 kg]

25131 Certifications: Safety: UL508, TUV EN60950-1, IEC60068-2-6 (Vibration) EN55022, CISPR22, EN61204-3 Class B, EN61000-3-2, EN61000-3-3, EN61000-4-2, EN61000-4-3, EN61000-4-4, EN61000-4-5, EN61000-4-6, EN61000-4-8, EN61000-4-11, EN55024, EN61000-6-2, EN50082-2, EN61204-3 A, IEC60068-2-6 (Vibration)

25131 Warranty: Lifetime



25131 Product Views



## Optional Power Supply 25175

### 25175 Features

- Variable AC input range
- Protected against Short Circuit, Overload, Over Voltage, Overheating
- Convection air cooling
- DIN rail mountable - can be mounted on a TS35 Standard DIN rail (TS35/7.5 or 15)
- Full load burn in test
- RoHS compliant

### 25175 Specifications

#### Output

Output Voltage	24VDC
Current Rating	5A
Power Rating	120 Watts
Ripple & Noise Max	120mVp-p
Voltage Range	24~28VDC
Voltage Tolerance	±1.0%
Line Regulation	±0.5%
Load Regulation	±1.0%
Setup, Rise Time	2500ms, 60ms
Hold Up Time	10ms

#### Input

Voltage Range	90 - 264VAC; 127 - 370VDC
Frequency Range	47~63Hz
Efficiency	88%
AC Current (Typical)	2.25A@115VAC; 1.3A@230VAC
Inrush Current (Cold)	20A@115VAC; 35A@230VAC
Leakage Current	<1mA@240VAC

#### Protection

Overload	105~130%
Overvoltage	29~33V
Over Temperature	Shut down o/p voltage, re-power on to recover

#### Dimensions

Width: 1.57" [40 mm] x Depth: 4.47" [113.5 mm] x Height: 4.94" [125.2 mm]

#### Environment

Operating Temp:	-20°C to +70°C
Storage Temp:	-40°C to +85°C
Humidity:	20% to 95% (non-condensing)
Weight	1.32 lbs. [0.6 kg]
MTBF	456.3Khrs (MIL-HDBK-217F (2 <sup>0</sup> 5 C)



**25175 Certifications**

Safety: UL508, TUV 62368-1; IEC60068-2-6 (Vibration);

EMC Emission: EN55032(CISPR32), EN61204-3 Class B, EN61000-3-2, EN61000-3-3;

EMC Immunity: EN61000-4-2, EN61000-4-3, EN61000-4-4, EN61000-4-5, EN61000-4-6, EN61000-4-8, EN61000-4-11, EN55024, EN61000-6-2, EN50082-2, EN61204-3, EAC TP TC 020



**Warranty**      5 Years

**Packaging**    typical:



**Product Views with Dimensions**

Dimensions are in mm.

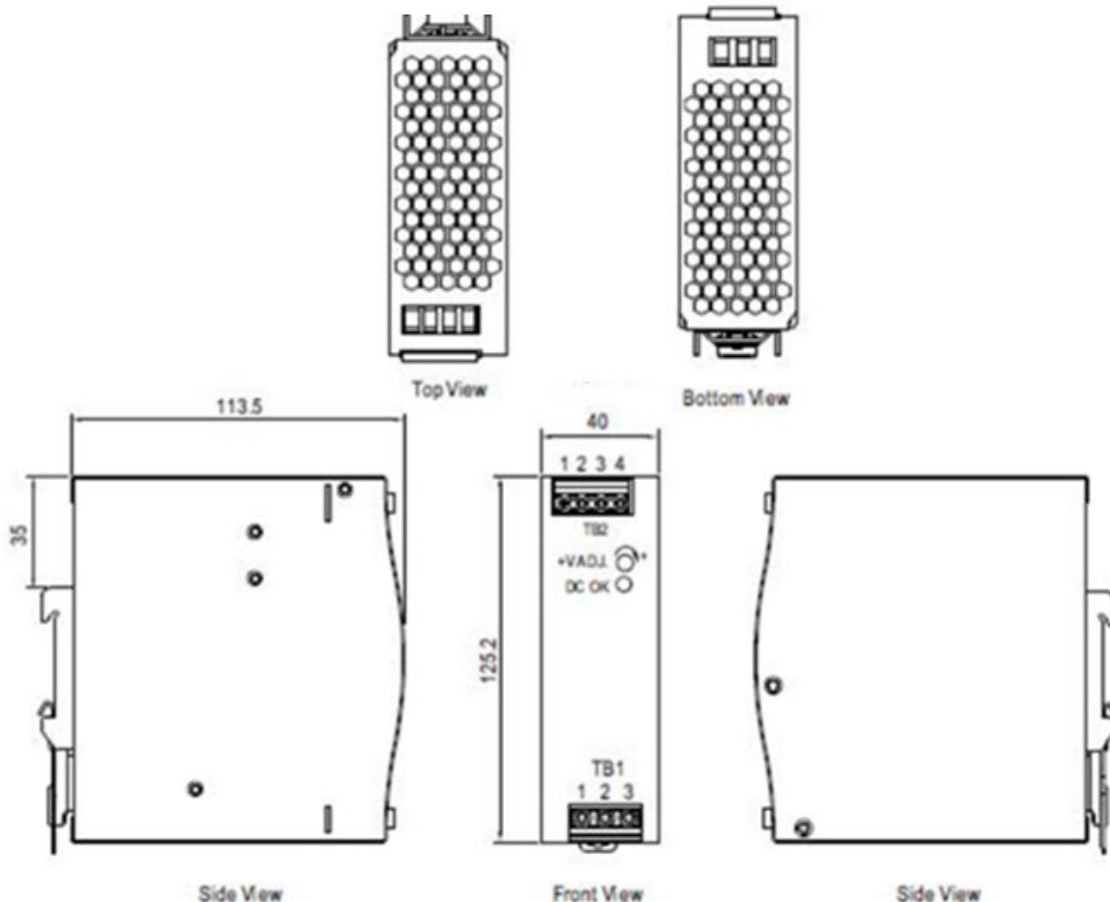

## 25175 Installation

1. Always allow good ventilation clearances, 5mm left and right, 40mm above and 20mm below, around the unit in use to prevent it from overheating. Also, a 10-15 cm clearance must be kept when the adjacent device is a heat source.
2. The appropriate mounting orientation for the unit is vertical, the input terminals at the bottom and output on the top. Mounting orientations other than that, such as upside down, horizontal, or table-top mounting, is not allowed.

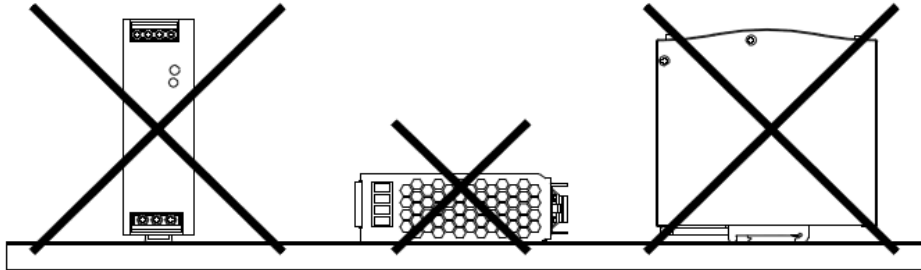

3. Use copper wire only, and recommended wires are shown as below.

AWG	18	16	14	12
Rated Current of Equipment (Amps)	7A	10A	15A	20A
Cross-section of Lead (mm <sup>2</sup> )	0.8	1.3	2.1	3.3
<b>Note:</b> Current each wire carries should be de-rated to 80% of the current suggested above when using 5 or more wires connected to the unit.				

Make sure that all strands of each stranded wire enter the terminal connection and the screw terminals are securely fixed to prevent poor contact. If the power supply possesses multi-output terminals, make sure each contact is connected to wires to prevent too much current stress on a single contact.

4. Use wires that can withstand temperatures of at least 80°C, such as UL1007.
5. Recommended wire strapping length is 5mm (0.197”).
6. Recommended screwdriver is 3mm, slotted type.
7. The recommended torque setting for terminals is: I/P = 7.5 kgf-cm (6.5 Lb-in) and O/P = 7.5 kgf-cm (6.5 Lb-in).
8. Suggested fuse and maximum number of the PSUs that can be connected to a circuit breaker at 230V:  
Fuse: T4A/L250V, Circuit breaker C16 = 5, D16 = 10.
9. Mounting Instructions: Mount as shown in figure only, with input terminals down, or else sufficient cooling will not be possible. Admissible DIN rail : TS35/7.5 or TS35/15.

For rail fastening :

(a) Tilt the unit slightly rearwards.

(b) Fit the unit over top hat rail.

(c) Slide it downward until it hits the

(d) Press against the bottom for locking.

(e) Shake the unit slightly to ensure the locking action.



stop.

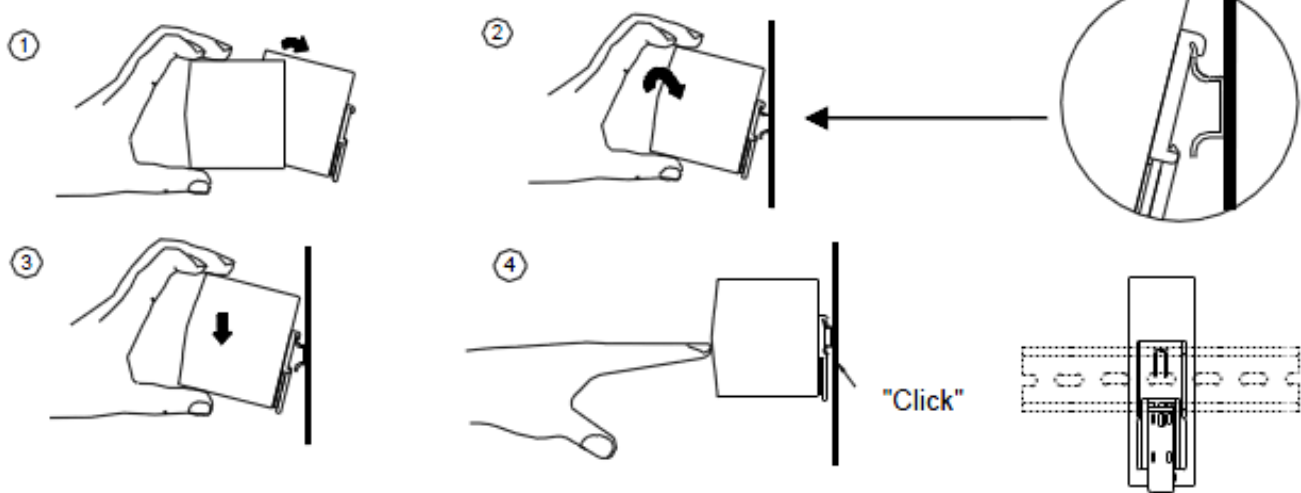

10. For other information about the products, please refer to [www.meanwell.com](http://www.meanwell.com) for more details.

### 25175 Warnings / Cautions !!

1) Risk of electrical shock and energy hazard. All failure should be examined by a qualified technician. Please do not remove the case of the power supply by yourself!

2) Risk of electric arcs and electric shock (danger to life). Connecting both the primary and the secondary sides together is not allowed.

3) Risk of burn hazard. Do not touch the unit in operation and shortly after disconnection!

4) Risk of fire and short circuit. The openings should be protected from foreign objects or dripping liquids.

5) Only install the unit in a pollution degree 2 environment (see Note 1 below).

6) Please do not install the unit in places with high moisture or near the water.

7) The maximum operating temperature is 45°C; do not install the unit in places with high ambient temperature or near fire source.

8) The FG (⊕) must be connected to PE (Protective Earth).

9) Output current and output wattage must not exceed the rated value on its specification.

10) Disconnect system from supply voltage. Before commencing any installation, maintenance or modification work: Disconnect your system from supply voltage. Make sure that inadvertent connection in circuit will be impossible!

11) For continued protection against risk of fire, replace only with same type and rating of fuse.

Pour ne pas compromettre la protection contre les risqué d'incendie, remplacer par un fusible de même type et de memes caractéristiques nominales.

**Note 1:** Pollution Degree 2 applies where there is only non-conductive pollution that might temporarily become conductive due to occasional condensation. Generally refers to dry, well-ventilated locations, such as control cabinets.

## Terminal Pin Assignments

### Terminal Pin No. Assignment (TB1)

Pin No.	Assignment
1	FG 
2	AC/N or DC -
3	AC/L or DC +

### Terminal Pin No. Assignment (TB2)

Pin No.	Assignment
1,2	DC OUTPUT -V
3,4	DC OUTPUT +V

## 25175 Install Views

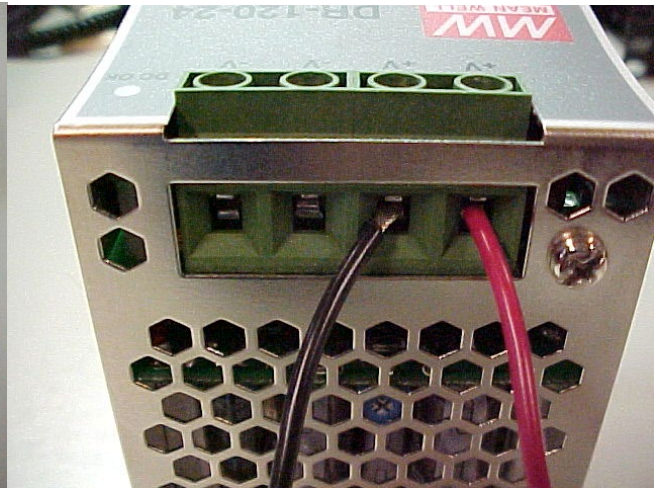
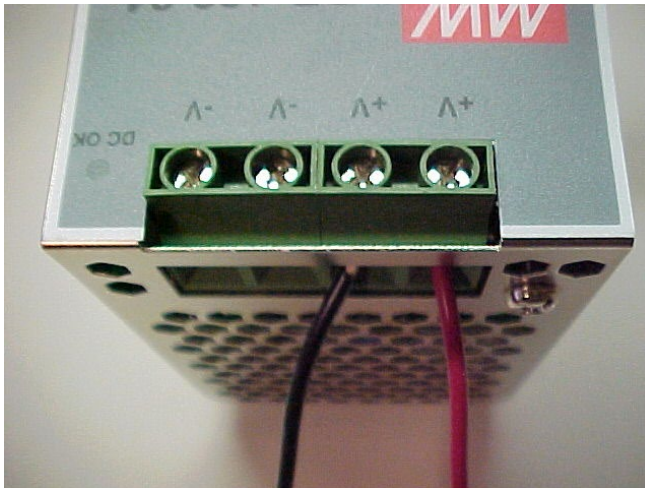

**+V ADJ Screw**

A small front panel hole provides access to a small Phillips screw; turn clockwise to increase or decrease voltage. Adjustable from 24V to 28VDC. No adjustment is usually needed. The 25175 power supply ships from the factory set to 24 VDC.

**DC OK LED**

Lights to indicate a DC OK condition (output 24 - 28VDC, 5.0A, 120 Watts).

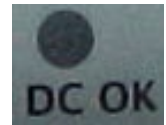



## Chapter 3 - Initial Switch Setup

### Initial Switch Setup via Web Browser

After powering up the switch for the first time, you can perform the initial switch setup using a web browser. For managing switch features, see the *Web User Guide* for details.

To begin the initial setup, you must change your PC's IP address and subnet mask to make sure the PC can communicate with the switch. After changing PC's IP address (for example, 192.168.1.250), then you can access the Web interface of the switch using the switch's default IP address as shown below.

**Note:** The switch factory default IP address is **192.168.1.77**. The switch factory default Subnet Mask is 255.255.255.0.

1. Power up the PC that you will use for the initial configuration. Make sure the PC has the Ethernet RJ45 connector to be connected to the switch via standard Ethernet LAN cable.
2. Change the PC's IP address and Subnet Mask so that it can communicate with the switch.
3. Power up the switch to be initially configured and wait until it has finished its start-up processes.
4. Connect the PC to any port on the switch using a standard Ethernet cable, and check the port LED on the switch to make sure the link status of the PC is OK.
5. Run your Web browser on the PC; enter the factory default IP address to access the switch's Web UI.

If your PC is configured correctly, the Login page displays as shown below.



If you do not see the above login page, try these steps:

- Refresh the web page.
  - Check to see if there is an IP address conflict issue.
  - Clear browser cookies and temporary internet files.
  - Check your PC settings again and repeat step 2.
6. Enter the factory default username (**admin**) and password (**admin**) on the Login page.
  7. Click "Login" to log into the switch. See the *Web User Guide* for additional information.

## Initial Switch Setup via CLI

Below is a brief description of the SM24DP4XA network connection.

1. Use an RJ-45 cable to connect a terminal or PC/terminal emulator to the switch port to access the CLI.
2. Attach the RJ-45 serial port on the switch front panel to the cable for Telnet/SSH CLI configuration.
3. Attach the other end of the DB-9 cable to a PC running Telnet or a terminal emulation program such as OpenSSH, HyperTerminal, HyperAccess, PuTTY, TSSSH or TeraTerm.
4. Power up the switch.
5. Set the communication program connection parameters. For example:

```
Baud rate:    115200
Stop bits:    1
Data bits:    8
Parity:       N
Flow control: none
```

The command-line interface (CLI) is a text-based interface. You can access the CLI through either a direct serial connection to the switch or a Telnet session. The SM24DP4XA default values are:

```
Username:     admin
Password:     admin
```

After you login successfully, the prompt displays as `SM24DP4XA#` if you are the first person to login; otherwise it may show `SM24DP4XA$`. The `#` means you have administrator rights with access to all system functions. The `$` means you have guest rights and are only allowed to view the system without permission to do any switch configuration settings.

```
Username: admin
Password:
SM24DP4XA#
```

**Note** that Telnet is not secure and can expose data to potential eavesdroppers. Consider using SSH for more secure communications. Per a Microsoft Tutorial dated 5/29/24 (<https://learn.microsoft.com/en-us/windows/terminal/tutorials/ssh>): "The latest builds of Windows 10 and Windows 11 include a built-in SSH server and client that are based on OpenSSH, a connectivity tool for remote sign-in that uses the SSH protocol. OpenSSH encrypts all traffic between client and server to eliminate eavesdropping, connection hijacking, and other attacks. Windows has a built-in SSH client and SSH server that you can use in Windows Terminal... "

## Chapter 4 - Troubleshooting

### Basic Troubleshooting

1. Make sure your switch model supports the feature or function attempted; see [Key Features](#) on page 5 and check the Release Notes for your firmware version.
2. Verify the install process; see [Chapter 2 – Installing the Switch](#) on page 22.
3. Verify the initial switch setup; see [Chapter 3 - Initial Switch Setup](#) on page 38.
4. Troubleshoot connected network devices to pinpoint the problem to the switch.
5. Run the System Diagnostics. See the *Web User Guide* or the *CLI Reference*.
6. Reset the switch; see [RST \(Reset\) button](#) on page 20.
7. Restore the switch to its factory default settings; see [RST \(Reset\) button](#) on page 20.
8. If using the CLI, try configuring / testing via the Web UI and vice versa. See the *Web User Guide* or the *CLI Reference*.

### Troubleshooting Table

The table below provides information to troubleshoot problems by taking actions based on suggested solutions.

**Table 6: Troubleshooting Table**

Symptoms	Possible Causes	Suggested Solutions
SYSTEM LED is Off	The switch is not receiving power.	<ol style="list-style-type: none"> <li>1. Check if correct power cord is connected firmly to the switch and to the AC/DC outlet socket.</li> <li>2. Power cycle the switch by unplugging and plugging the power cord back into the switch.</li> <li>3. If the LED is still off, try to plug power cord into a different AC/DC outlet socket to make sure correct AC/DC source is supplied.</li> </ol>
Port Status LED is Off	The port is not connected, or the connection is not working.	<ol style="list-style-type: none"> <li>1. Check if the cable connector plug is firmly inserted and locked into the port at both the switch and the connected device.</li> <li>2. Make sure the connected device is up and running correctly.</li> <li>3. If the symptom still exists, try different cable or different port, in order to identify if it is related to the cable or specific port.</li> <li>4. Check if the port is disabled in the configuration settings via the Web user interface.</li> </ol>



## LED Troubleshooting

Type	LED	Color	Function
Global	PWR AC	Green	Lights when AC power is on.
Global	PWR DC	Green	Lights when DC power is on.
Global	SYS	Green	Blinking when system is booting; Lit when system is coming up.
Global	ALARM	Red	Always off, until any system error message turns the LED on.
SFP Port 1-24	SFP Link/Act/Speed	Green/ Amber	Light when Fiber connection with remote device is good. Blinks when any traffic is present. The light is green when linking up at 1000Mbps. The light is Amber when linking up at 100Mbps.
TP Port 21-24	Link/Act/Speed	Green/ Amber	Lit Green when TP link on at 10/1000Mbps speed. Lit Amber when TP link on at 100Mbps speed. Blinks when any traffic is present.
TP Port 25	Link/Act/Speed	Green/ Amber	Lit Green when TP link on 10/1000Mbps speed. Lit Amber when TP link on 100Mbps speed. Blinks when any traffic is present.
SFP+ Port 1-4	Link/Act/Speed	Blue / Green	Light Blue when SFP+ link up at 10Gbps speed. Light Green when SFP+ link up at 1Gbps speed. Blinks when any traffic is present.

## Device Label and Packaging Label Information

In addition to the device CLI and Web GUI, you can find device information on the box label and device label.



Package Label

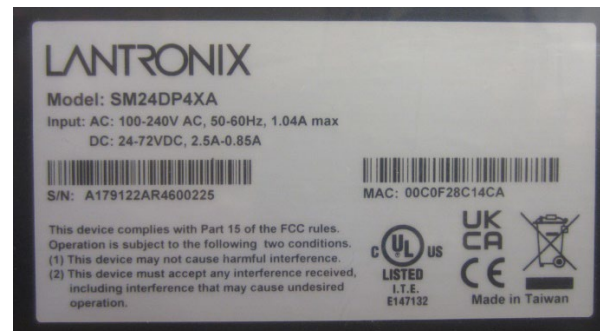

Product Label

## Record Device and System Information

After performing the troubleshooting steps, and before calling or emailing Technical Support, please record as much information as possible to help the Tech Support Specialist.

1. From the Web UI, select the **Monitor > System > Information** menu path. From the CLI, use the **show** commands needed to gather the information below or as requested by the Tech Support Specialist.

2. Model Name: \_\_\_\_\_ Firmware Version: \_\_\_\_\_

Hardware Version: \_\_\_\_\_ Serial Number: \_\_\_\_\_

3. Record LED Status: \_\_\_\_\_

4. Provide additional information to your Tech Support Specialist. See the "Troubleshooting" section above.

Your Lantronix service contract number: \_\_\_\_\_

Describe the failure: \_\_\_\_\_

Describe any action(s) already taken to resolve the problem (e.g., changing mode, rebooting, etc.): \_\_\_\_\_

The model and serial numbers of other Lantronix products in the network: \_\_\_\_\_

Describe your network environment (layout, cable type, etc.): \_\_\_\_\_

SFPs Used: \_\_\_\_\_

Power Source used: \_\_\_\_\_

The device history (i.e., have you returned the device before, is this a recurring problem, etc.): \_\_\_\_\_

Any previous Return Material Authorization (RMA) numbers: \_\_\_\_\_

## Chapter 5 - Regulatory and Safety Information

### Certifications

<b>Electromagnetic Emissions (EMC)</b>
CE, FCC Part 15 Class A
Safety: UL 62368

### Compliance and Safety Statements

FCC, Class A: This product has been tested and found to comply with the limits for a Class A digital device pursuant to Part 15 of the FCC Rules. These limits are designed to provide reasonable protection against harmful interference when the equipment is operated in a commercial environment. This product generates, uses, and can radiate radio frequency energy and, if not installed and used in accordance with the manufacturer's instruction manual, may cause harmful interference with radio communications. Operation of this product in a residential area is likely to cause harmful interference, in which case you will be required to correct the interference at your own expense.

This device complies with Part 15 of the FCC Rules. Operation is subject to the following two conditions:

- 1) This device may not cause harmful interference.
- 2) This device must accept any interference received, including interference that may cause undesired operation.

CE MARK DECLARATION OF CONFORMANCE FOR EMI AND SAFETY (EEC): This equipment has been tested and found to comply with the protection requirements of European Emission Standard EN55022/EN61000-3 and the Generic European Immunity Standard EN55024.

### High Risk Activities Disclaimer

Components, units, or third-party products used in the product described herein are NOT fault-tolerant and are NOT designed, manufactured, or intended for use as on-line control equipment in the following hazardous environments requiring fail-safe controls: the operation of Nuclear Facilities, Aircraft Navigation or Aircraft Communication Systems, Air Traffic Control, Life Support, or Weapons Systems ("High Risk Activities"). Lantronix and its supplier(s) specifically disclaim any expressed or implied warranty of fitness for such High Risk Activities.

### Accessibility Statement

In our effort to help provide a fully accessible and optimized experience for our website visitors, lantronix.com has taken careful measures to help ensure an enhanced user experience, whether the website visitor is using assistive technologies such as a screen reader, magnifier or other assistive technology to access the website. For more information see <https://www.lantronix.com/accessibility-statement/>.

## CE EMC Test

**Standard:** EN 55032:2012/AC:2013 Class A  
 EN61000-3-2:2014  
 EN61000-3-3:2013  
 AS/NZS CISPR 32:2013 Class A  
 EN 55024:2010/A1:2015

### Test Standards

Test Item	Test Standard and Procedure
Radiated and Conducted Emissions	European Standard EN 55032 Class A. Australian Standard AS/NZS CISPR 32 Class A
Harmonics	European Standard EN 61000-3-2
Voltage Fluctuations	European Standard EN 61000-3-3
EMS	European Standard EN 55024 (ESD: IEC 61000-4-2, RS: IEC 61000-4-3, EFT: IEC 61000-4-4, SURGES: IEC 61000-4-5, CS: IEC 6100-4-6, PFMF: IEC 61000-4-8, DIPS: IEC 61000-4-11)

### Notice for Class A Product

This equipment is compliant with Class A of CISPR 32. In a residential environment this equipment may cause radio interference.

## FCC EMI Test

**Standard:** 47 CFR FCC Rules and Regulations Part 15 Subpart B,  
 Class A Digital Device  
 ICES-003 Issue 6, Class A

### Test Standards

Radiated and Conducted Emissions: ANSI C63.4 with FCC Method 47 CFR Part 15, Subpart B, Class A Digital Device, CISPR PUB. 22 and Canada Standard ICES-003 Issue 6, Class A

### Innovation, Science and Economic Development Canada ICES-003 Compliance:

CAN ICES-3 (A)/NMB-3(A)

### User Information

**Caution:** Changes or modifications not expressly approved by the party responsible for compliance could void the user's authority to operate the equipment.

This equipment has been tested and found to comply with the limits for a Class A digital device, pursuant to part 15 of the FCC Rules. These limits are designed to provide reasonable protection against harmful interference when the equipment is operated in a commercial environment. This equipment generates, uses and ca radiate radio frequency energy and, if not installed in accordance with the instruction manual, may cause harmful interference to radio communications. Operation of this equipment in a residential area is likely to cause harmful interference in which case the user will be required to correct the interference at his own expense.

## EU Declaration of Conformity

# LANTRONIX®



### EU DECLARATION OF CONFORMITY

**Manufacturer's Name:** LANTRONIX INC.  
**Manufacturer's Address:** 48 Discovery, Suite 250  
 Irvine, CA. 92618. USA

**Product Family:** SM24DP4XA

**Manufacturer's Quality System:**



ISO 9001:2015 Certificate No. 74 300 4282 TUV Rheinland

**Applicable EU Directives:**

**Low Voltage Directive (2014/35/EU)**

- EN 62368-1:2014+A11:2017

**EMC Directive (2014/30/EU)**

- EN 55032:2015+A11:2020
- EN 55035:2017+A11:2020
- EN IEC 61000-3-2:2014
- EN IEC 61000-3-3:2013+A1:2021

EU Directive 2011/65/EU for Restriction of Hazardous Substance (RoHS2) with exemption 7(c)-I and XX (note: different products may have different exemptions, confirm with RoHS team)

**Statement of Conformity:** The product specified above complies with applicable EU directive referenced, including the application of sound engineering practice.

Signature: Eric Bass Date: 2 May 2024

Name: Eric Bass Title: VP of Engineering

CERT-DOC-XPRESS PRO rev C

## UK Declaration of Conformity

# LANTRONIX®

# UK CA

### UK DECLARATION OF CONFORMITY

**Manufacturer's Name:** LANTRONIX INC.  
**Manufacturer's Address:** 48 Discovery, Suite 250, Irvine, CA 92618 USA  
**Product Family:** SM24DP4XA

**Manufacturer's Quality System:**



ISO 9001:2015 Certificate No. 74 300 4282 TUV Rheinland  
 Electrical Equipment Regulations 2016

- EN 62368-1:2014+A11:2017

Electromagnetic Compatibility Regulations 2016

- EN 55032:2015+A11:2020
- EN 55035:2017+A11:2020
- EN IEC 61000-3-2:2014
- EN IEC 61000-3-3:2013+A1:2021

UK SI 2012 No. 3032 for Restriction of Hazardous Substance (RoHS2) with exemption 7(c)-I and 6(c).

- 1) 2011/65/EU Restriction of the use of Hazardous Substances in EEE (RoHS)
  - 2) 2015/863/EU Change of Annex II from 2011/65/EU
  - 3) Directive 2018/736/EU[7(c)-I] and 2018/741/EU[6(c)]
- BS EN IEC 63000 : 2018

**Statement of Conformity:** The product specified above meets the test requirements of the relevant legislation of United Kingdom, including the application of sound engineering practice.

Signature: Eric Bass Date: 2 May 2024

Name: Eric Bass Title: VP of Engineering

## Cautions and Warnings

**Cautions** indicate that there is the possibility of poor equipment performance or potential damage to the equipment. **Warnings** indicate that there is the possibility of injury to person.

Cautions and Warnings appear here and may appear throughout this manual where appropriate. Failure to read and understand the information identified by this symbol could result in poor equipment performance, damage to the equipment, or injury to persons.

**Caution :** While installing or servicing the power module, wear a grounding device and observe all electrostatic discharge precautions. Failure to observe this caution could result in damage to, or failure of the power module.

**Warning:** Do not connect the power module to an external power source before installing it into the chassis. Failure to observe this warning could result in an electrical shock, even death.

**WARNING:** The power module has a provision for grounding. Equipment grounding is vital to ensure safe operation. The installer must ensure that the power module is properly grounded during and after installation. Failure to observe this warning could result in an electric shock, even death.

**WARNING:** A readily accessible, suitable National Electrical Code (NEC) or local electrical code approved disconnect device and branch-circuit protector must be part of the building's installed wiring to accommodate permanently connected equipment. Failure to observe this warning could result in an electric shock, even death.

**WARNING:** Turn the external power source OFF and ensure that the power module is disconnected from the external power source before performing any maintenance. Failure to observe this warning could result in an electrical shock, even death.

**WARNING:** Ensure that the disconnect device for the external power source is OPEN (*turned OFF*) before disconnecting or connecting the power leads to the power module. Failure to observe this warning could result in an electric shock, even death.

**Warning:** Because invisible radiation might be emitted from the aperture of the port when no fiber cable is connected, avoid exposure to radiation and do not stare into open apertures.

**General Laser Safety Guidelines:** When working around ports that support optical transceivers, observe the following safety guidelines to prevent eye injury:

- Do not look into unterminated ports or at fibers that connect to unknown sources.
- Do not examine unterminated optical ports with optical instruments.
- Avoid direct exposure to the beam.

## Electrical Safety Warnings

### Electrical Safety

IMPORTANT: This equipment must be installed in accordance with safety precautions.

### Elektrische Sicherheit

WICHTIG: Für die Installation dieses Gerätes ist die Einhaltung von Sicherheitsvorkehrungen erforderlich.

### Elektrisk sikkerhed

VIGTIGT: Dette udstyr skal installeres i overensstemmelse med sikkerhedsadvarselne.

### Elektrische veiligheid

BELANGRIJK: Dit apparaat moet in overeenstemming met de veiligheidsvoorschriften worden geïnstalleerd.

### Sécurité électrique

IMPORTANT: Cet équipement doit être utilisé conformément aux instructions de sécurité.

### Sähköturvallisuus

TÄRKEÄÄ: Tämä laite on asennettava turvaohjeiden mukaisesti.

### Sicurezza elettrica

IMPORTANTE: questa apparecchiatura deve essere installata rispettando le norme di sicurezza.

### Elektrisk sikkerhet

VIKTIG: Dette utstyret skal installeres i samsvar med sikkerhetsregler.

### Segurança eléctrica

IMPORTANTE: Este equipamento tem que ser instalado segundo as medidas de precaução de segurança.

### Seguridad eléctrica

IMPORTANTE: La instalación de este equipo deberá llevarse a cabo cumpliendo con las precauciones de seguridad.

### Elsäkerhet

OBS! Alla nödvändiga försiktighetsåtgärder måste vidtas när denna utrustning används.



**Lantronix Corporate Headquarters**

48 Discovery, Suite 250  
Irvine, CA 92618, USA  
Toll Free: 800-526-8766  
Phone: 949-453-3990  
Fax: 949-453-3995

**Technical Support**

Online: <https://www.lantronix.com/technical-support/>

**Sales Offices**

For a current list of our domestic and international sales offices, go to the Lantronix web site at [www.lantronix.com/about/contact](http://www.lantronix.com/about/contact).