



M/E-ISW-FX-02 Series
Industrial Stand-Alone Media Converters
User Guide

Part Number 33767
Revision C January 2024

Intellectual Property

© 2022-2024 Lantronix, Inc. All rights reserved. No part of the contents of this publication may be transmitted or reproduced in any form or by any means without the written permission of Lantronix.

Lantronix is a registered trademark of Lantronix, Inc. in the United States and other countries. All other trademarks and trade names are the property of their respective holders.

Patented: <https://www.lantronix.com/legal/patents/>; additional patents pending.

Warranty

For details on the Lantronix warranty policy, please go to our web site at <http://www.lantronix.com/support/warranty>.

Contacts

Lantronix Corporate Headquarters

48 Discovery, Suite 250
Irvine, CA 92618, USA
Toll Free: 800-526-8766
Phone: 949-453-3990
Fax: 949-453-3995

Technical Support

<https://www.lantronix.com/technical-support/>

Sales Offices

For a current list of our domestic and international sales offices, go to www.lantronix.com/about/contact.

Disclaimer

All information contained herein is provided "AS IS." Lantronix undertakes no obligation to update the information in this publication. Lantronix does not make, and specifically disclaims, all warranties of any kind (express, implied or otherwise) regarding title, non-infringement, fitness, quality, accuracy, completeness, usefulness, suitability or performance of the information provided herein. Lantronix shall have no liability whatsoever to any user for any damages, losses and causes of action (whether in contract or in tort or otherwise) in connection with the user's access or usage of any of the information or content contained herein. The information and specifications contained in this document are subject to change without notice.

Revision History

Date	Rev	Notes
12/19/18	A	Initial release of the M/E-ISW-FX-02 Series.
1/10/23	B	Initial Lantronix re-brand. Update artwork.
1/18/24	C	Update Optional Accessories.

Table of Contents

Product Description	4
Ordering Information	4
Features	4
Family Portrait.....	5
Package Contents	5
Installation	6
Electrostatic Discharge (ESD)	6
Copper and Fiber Ports	6
Connect Fiber Cables	6
Connect the Twisted-pair Copper Cable.....	7
Connecting Power	7
Connect to DC (12 – 48 VDC) or AC (24 – 36 VAC) power.....	7
Mains AC Power.....	8
Installing DIN Rail Clip.....	8
Insert and Connecting the SFP.....	9
Removing an SFP Module	9
Operation.....	10
Status LEDs	10
Product Features	10
Congestion Reduction	10
Auto-Negotiation.....	10
Auto MDI/MDI-X	10
Link Pass-Through (LPT)	11
Active Link Pass-Through (ALPT) (only on SFP version)	11
Automatic Link Restoration	12
Full-Duplex Flow Control.....	12
Half-Duplex Flow Control (512-Bit Rule)	12
Flow Control	12
Rate Conversion.....	12
Distance Extension.....	13
Far-End Fault.....	13
Optic and Cable Specifications.....	14
Fiber cable.....	14
Optics	14
Copper Cable	15
Technical Specifications.....	16
Application Example.....	17
Troubleshooting	18
Contact Us.....	19
Compliance Information	19
Declaration of Conformity	19
FCC Regulations	20
Canadian Regulations	20
European Regulations.....	20

Product Description

The M/E-ISW Series is a hardened Fast Ethernet Mini media converter that provides a cost effective, plug-and-play media conversion between 10/100Base-TX ports and 100Base-FX ports for hardened or outdoor 10/100 environments. With its supported operating temperature range of -40°C to 75°C, the Mini offers a space saving alternative for converting copper to fiber in extreme environments.

The small mechanical size allows use in enclosures with space constraints, to easily integrate fiber into industrial, hardened, or outdoor locations to reach devices at the edge of the network. No configuration is required. The industrial minis are available with LC, ST or SC fiber interfaces and are available for multimode or single mode fiber; single fiber options are also available via the SFP port.

Ordering Information

Model Number	Description
M/E-ISW-FX-02(SFP)	10/100Base-TX RJ-45 to 100Base-FX open SFP slot
M/E-ISW-FX-02	10/100Base-TX RJ-45 to 100Base-FX MM ST 2km
M/E-ISW-FX-02(SC)	10/100Base-TX RJ-45 to 100Base-FX MM SC 2km
M/E-ISW-FX-02(MMLC)	10/100Base-TX RJ-45 to 100Base-FX MM LC 2km
M/E-ISW-FX-02(SM)	10/100Base-TX RJ-45 to 100Base-FX SM SC 20km
Optional Accessories (order separately)	
SPS-UA12DHT	100-240 VAC Input Power Supply; 0°C to +70°C Operating temp.
25165	Industrial DIN Rail Mounted Power Supply
WMBM	Wall Mount Bracket for Mini Converters
SFP Modules	Supports Hardened Grade SFP Modules; see our SFPs webpage .

Note: Typical maximum cable distance. Actual distance depends on the physical characteristics of the network.

Features

- Unit and Port LEDs for quick status
- Auto-Negotiation
- Fixed Full-Duplex on fiber
- Link Pass Though
- Automatic Link Restoration
- Auto MDI/MDI-X
- Far End Fault (FEF)
- Overload Current Protection
- Reverse Polarity Protection
- No configuration required

Family Portrait

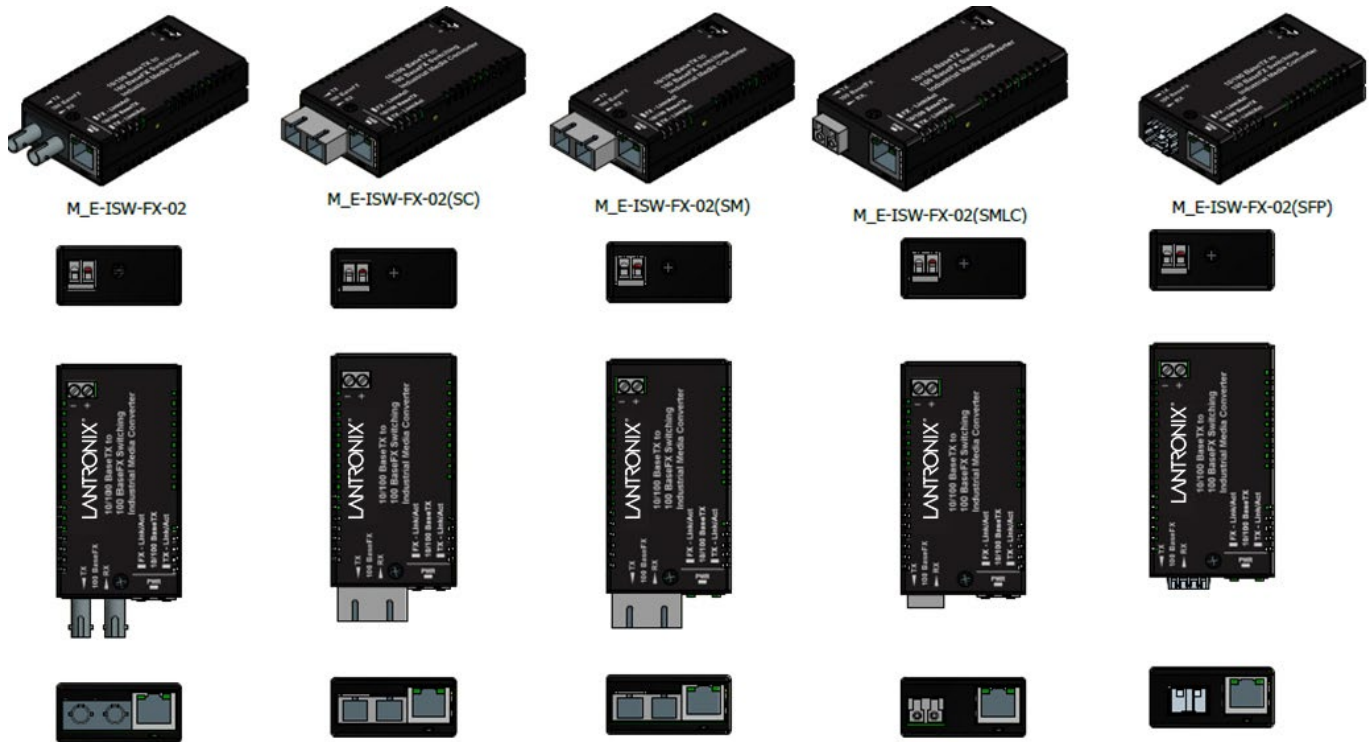

Package Contents

Verify that you have received the items below. Contact your sales representative if any item is missing. Please save the packaging for possible future use.

- One M/E-ISW-FX-02 Series media converter
- One DIN Rail clip
- One Velcro strip
- One Documentation Postcard
- One Barrel Connector Pig-tail Cable
- Four Rubber Feet

Installation

Electrostatic Discharge (ESD)

Observe these ESD precautions when installing or handling the M/E-ISW-FX-02:

- Do not remove the M/E-ISW-FX-02 from its protective packaging until you are ready to install it.
- Wear an ESD wrist grounding strap before handling the M/E-ISW-FX-02 or its component. If you do not have a wrist strap, maintain grounded contact with the unit throughout any procedure requiring ESD protection.

Copper and Fiber Ports

The figure below shows the front panel of the M/E-ISW-FX-02.

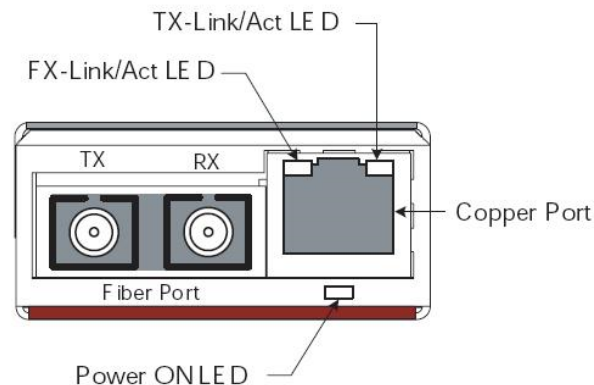

Connect Fiber Cables

Full duplex (always ON) is on the fiber side only, therefore, the 512-Bit Rule does not apply. Cable lengths are constrained by the cable requirement.

1. Use a 100Base-FX or -LX10 fiber cable with male, two-stranded TX to RX connectors at each end.
2. Connect the fiber cable to the M/E-ISW-FX-02 as follows:
 - Connect the male TX cable connector to the female TX port.
 - Connect the male RX cable connector to the female RX port.
3. Connect the fiber cable to the other device (*media converter, hub, etc.*) as follows:
 - Connect the male TX cable connector to the female RX port.
 - Connect the male RX cable connector to the female TX port.

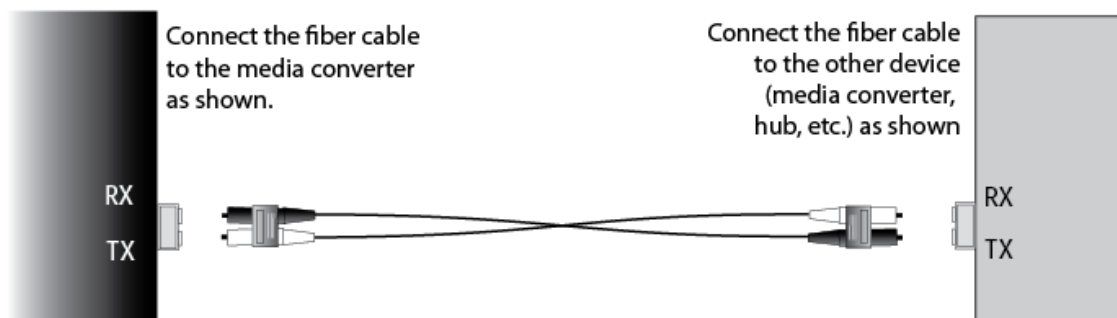

Connect the Twisted-pair Copper Cable

The Auto MDI/MDI-X feature allows either MDI (*straight-through*) or MDI-X (*crossover*) cable connections to be configured automatically, according to network conditions.

- If half-duplex mode is used, refer to the 512-Bit Rule.
- If full-duplex mode is used, the 512-Bit Rule does not apply. The cable lengths are constrained by the cable requirements.

Perform these steps:

1. Locate a 10Base-T or 100Base-TX cable with RJ-45 connectors installed at both ends.
2. Connect the RJ-45 connector at one end of the cable to the RJ-45 port on the M/E-ISW-FX-02.
3. Connect the RJ-45 connector at the other end of the cable to the RJ-45 port on the other device (*switch, workstation, etc.*).

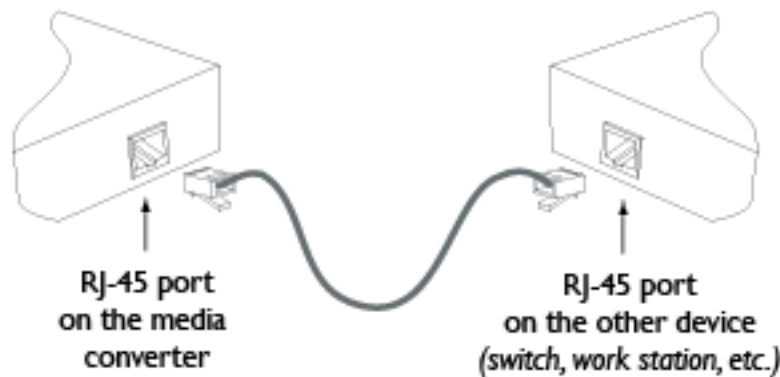

Connecting Power

Connect to DC (12 – 48 VDC) or AC (24 – 36 VAC) power

Note: The Pitch EURO style terminal block accepts 24-14 gauge wire.

1. Turn OFF the main power source.
2. Strip the power wires to the proper strip length.
3. Loosen the two screws in the terminal block.
4. Insert the power wires into the terminal block as shown (note polarity).
5. Tighten the screw for each wire.
6. Connect the other end of the power wires to the main power source (note polarity).
7. Turn main power source ON; the power LED on the front panel should light.

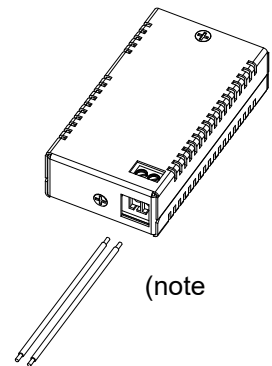

Mains AC Power

The optional SPS-UA12DHT external mains AC power supply, supplying 12 VDC, can be used to power the M/E-ISW-FX-02 via the included barrel connector pig-tail cable. (Power supply sold separately.)

Installing DIN Rail Clip

Parts shown right:

To install the DIN rail onto the media converter:

1. Position the DIN rail clamp to the side of the M/E-ISW-FX-02 as shown below.

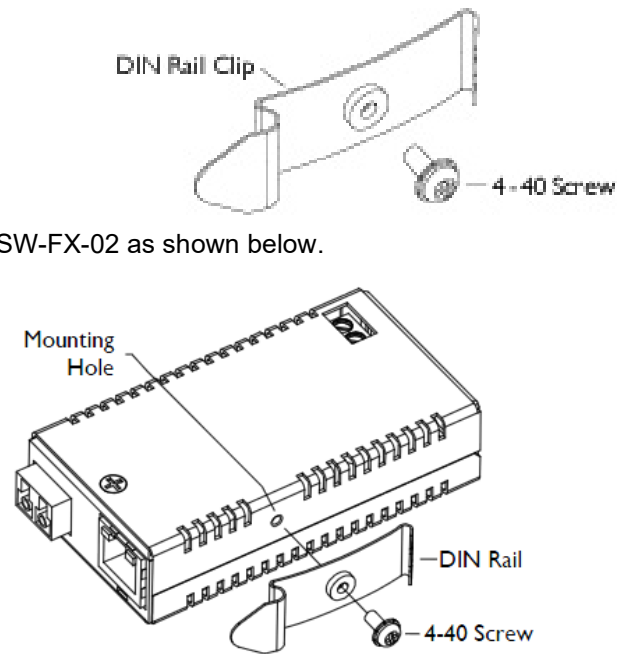
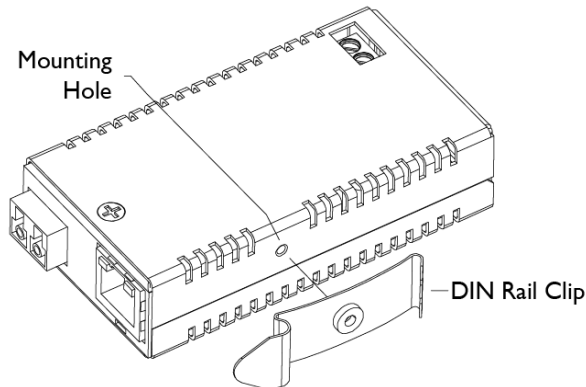

2. Position the 4-40 screw to attach the DIN rail to the M/E-ISW-FX-02 as shown above left.
3. Insert and tighten the 4-40 screw until the DIN rail clip appears as shown above right. When the DIN Rail Clip is attached, there should be no gap between the Clip and the M/E-ISW-FX-02 as shown below.

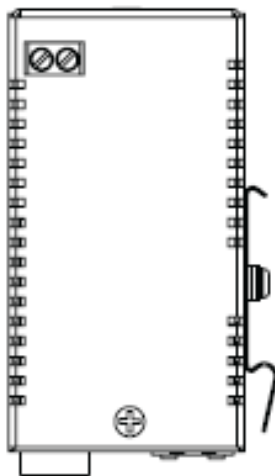

When the DIN Rail *Clip* is attached, there should be no "gap" between the *Clip* and media converter as shown.

Insert and Connecting the SFP

Perform the steps below to install an SFP in the M/E-ISW-FX-02. Refer to the documentation that came with your SFP for specific requirements.

1. Remove the SFP transceiver module from its protective packaging. Note: Do not remove the optical bore dust plugs until directed to do so in a later procedure.
2. Check the slot orientation. Position the SFP device at the desired installation slot, with the label facing correctly.
3. Carefully slide the SFP device into the slot, aligning it with the internal installation guides.
4. Ensure that the SFP device is firmly seated against the internal mating connector.
5. Remove the dust plug from the connector. Save the dust plug for future use.
6. Connect the fiber cable to the fiber port connector of the SFP device. Make sure the SFP release latch is in the up (closed) position when you insert the cable connector into the SFP.
7. Attach the other end of the cable into the other device.

Removing an SFP Module

Caution: Be careful when removing the SFP from a device. Some SFP transceiver module temperatures may exceed 160°F (70°C) and be too hot to touch with bare hands. **Note:** Do not remove and replace the SFP modules more often than necessary; excessive SFP removing and replacing can shorten the SFPs useful life.

1. Attach an ESD-preventive wrist strap to your wrist and to the ESD ground connector or a bare metal surface on your chassis.
2. For future reattachment of fiber-optic cables, note which connector plug is send (TX) and which is receive (RX).
3. Remove the SFP transceiver module:
 - a. If the SFP transceiver module has an actuator button latch, gently press the actuator button on the front of the SFP transceiver module until it clicks, and the latch mechanism releases the SFP transceiver module from the socket connector. Grasp the actuator button between your thumb and index finger, and carefully pull the SFP transceiver module straight out of the module slot.
 - b. If the SFP transceiver module has a bail clasp latch, pull the latch out and down to eject the SFP transceiver module from the socket connector. If the bail clasp latch is obstructed and you cannot use your index finger to open it, use a small, flat-blade screwdriver or other long, narrow instrument to open the bail clasp latch. Grasp the SFP transceiver module between your thumb and index finger, and carefully remove it from the socket.
4. Replace the Dust Plug.
5. Place the removed SFP transceiver module in an antistatic bag or other protective package.

Operation

Status LEDs

Use the status LEDs to monitor the M/E-ISW-FX-02 Series media converter operation in the network. LED descriptions are as follows:

FX-Link/Act LED

Green ON = Link (*fiber*)
Flashing = Activity

TX-Link/Act LED

Green ON = Link
Flashing = Activity

Power LED

Green ON = Connected to power

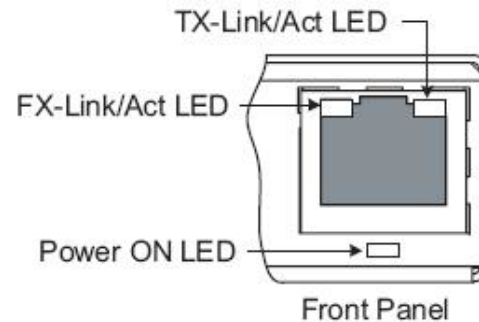

Product Features

The M/E-ISW-FX-02 Series features include Congestion reduction, Auto-Negotiation, Auto MDI/MDI-X, Link Pass-Through (LPT), Automatic Link Pass-Through (ALPT), Automatic link restoration, Full-Duplex flow control, Half-Duplex flow control, Flow control, Distance extension, Rate conversion, and Far-end fault. These features are described below.

Congestion Reduction

The M/E-ISW-FX-02 Series media converters do not forward collision signals or error packets from one collision domain to another, resulting in improvements in baseline network performance. In addition, the media converter filters packets destined for local devices, which reduces network congestion.

Auto-Negotiation

The Auto-Negotiation feature is ON permanently for the M/E-ISW-FX-02 Series media converters. Auto-Negotiation allows the media converter to configure itself automatically to achieve the best possible mode of operation over a link. It broadcasts speed (10 Mb/s or 100 Mb/s) and duplex capabilities (full or half) to the other device and negotiates the best mode of operation. Auto-Negotiation allows quick and easy installation because the optimal link is established automatically.

In a scenario where an auto-negotiation device is linked to a non-negotiating device, the negotiating device via parallel detection recognizes the speed of that second device then establishes the best operating speed (10Mb/s or 100Mb/s) at half duplex.

Auto MDI/MDI-X

The Auto MDI/MDI-X feature allows using either straight-through (MDI) or crossover (MDI-X) copper cables when connecting to 10Base-T or 100Base-TX devices. Auto MDI/MDI-X determines the characteristics of the connection and automatically configures the device to link up, regardless of the copper cable configuration, MDI or MDI-X.

Link Pass-Through (LPT)

The Link Pass-Through feature (see below) allows the media converter to monitor both the fiber and copper RX (receive) ports for loss of signal. In the event of an RX signal loss (1), the media converter will automatically disable the TX (transmit) signal (2), thus “passing through” the link loss (3). The far-end device is automatically notified of the link loss (4), which prevents the loss of valuable data unknowingly transmitted over an invalid link.

Link Pass-Through is a troubleshooting feature that allows the media converter to monitor both the fiber and copper RX ports for loss of signal. With the loss of RX signal on one media port, the converter will automatically disable the TX signal of the other media port, thus “passing through” the link loss.

- End device automatically notified of link loss
- Prevents loss of valuable data unknowingly transmitted over invalid link

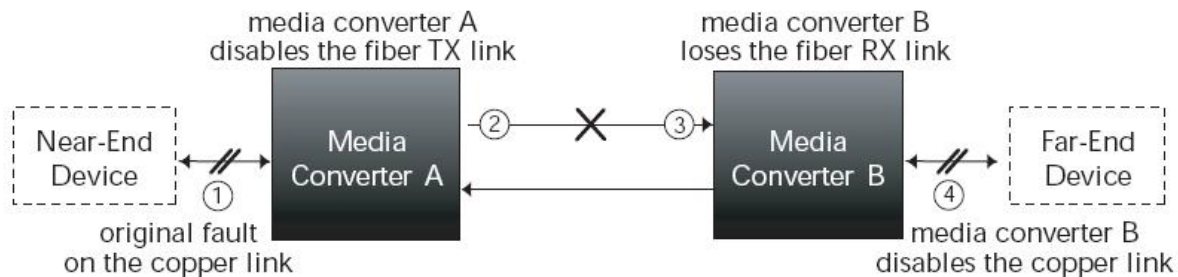

Note: With link pass-through, both copper and fiber cables must be installed before the LEDs will light.

Active Link Pass-Through (ALPT) (only on SFP version)

The SFP version (M/E-ISW-FX-02(SFP)) supports Active Link Pass-Through, which isolates network issues during product installation and troubleshooting (see below). **Active** LPT is a form of LPT that requires the links to become Active before LPT becomes Active.

With Active LPT there are 2 states: **Diagnostic** and **Active**.

The media converter enters the **Diagnostic** state when either of the following conditions is met:

- Upon power-up of the converter.
- Upon removing the converter’s SFP module (if equipped).

In the **Diagnostic** state, the link for each of the media converter’s ports can come up independently of each other, just like a converter that has no LPT functionality, or a converter that has LPT disabled. The Diagnostic state is helpful during first power up, before all links of a circuit are connected, as it allows the installer to see each link turn on as the cables are plugged in. It’s also helpful for finding the location of a fault, if one exists.

The media converter remains in the Diagnostic state until the following condition is met:

- The link status for both media converter’s ports is up, simultaneously.

After that condition is met, ALPT enters the **Active** state. It remains in the Active state until the converter is either powered down, or its SFP module is removed. In the Active state, Active LPT works as shown below (the same as when regular LPT is enabled).

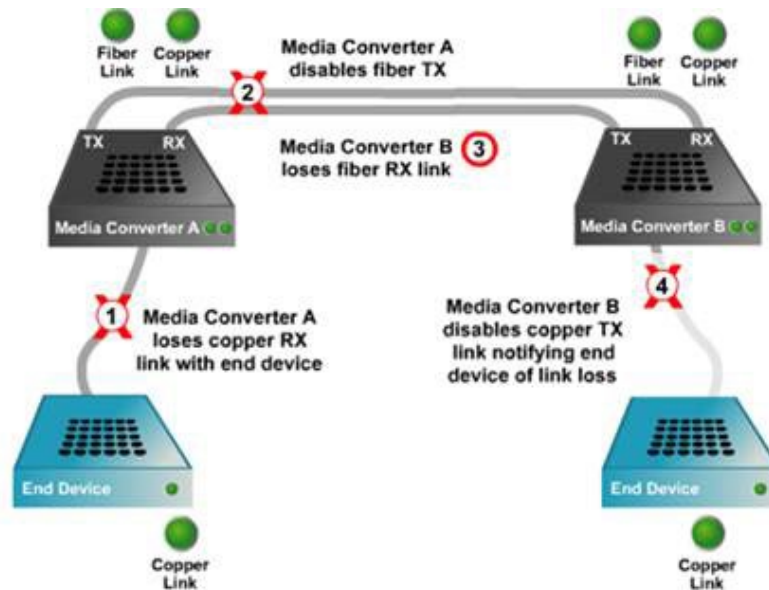

Automatic Link Restoration

The media converter will automatically re-establish the link when connected to switches if the link is lost.

Full-Duplex Flow Control

In a full-duplex network, maximum cable lengths are determined by the type of cables used—see page 1 (front cover) for M/E-ISW-FX-02 Series cable specifications. The 512-Bit Rule does not apply in a full-duplex network. **Note:** Full duplex is ON permanently for the fiber port only.

Half-Duplex Flow Control (512-Bit Rule)

In a half-duplex network, the maximum cable lengths are determined by the roundtrip delay limitations of each Fast Ethernet collision domain. (A collision domain is the longest path between any two terminal devices; e.g., a terminal, switch, or router.) The 512-Bit Rule determines the maximum length of cable permitted by calculating the round-trip delay in bit-times (BT) of a particular collision domain. If the result is less than or equal to 512 BT, the path is good.

Flow Control

The process of adjusting the flow of data from one device to another ensures that the receiving device can handle all the incoming data. This is particularly important where the sending device is capable of transmitting data much faster than the receiving device can accept it.

Rate Conversion

The M/E-ISW-FX-02 Series media converters allow connection of 10Mb/s terminal devices on a 10Base-T legacy Ethernet copper network to 100Mb/s terminal devices on a 100Base-TX Fast Ethernet copper network and/or to 100Mb/s terminal devices on a 100Base-FX or –LX10 Fast Ethernet fiber network.

Distance Extension

The M/E-ISW-FX-02 Series media converters can segment one (1) 10Base-T copper Ethernet and/or 100Base-TX copper Fast Ethernet, and one (1)100Base-FX or –LX10 fiber Fast Ethernet collision domain:

- In a half-duplex Ethernet or Fast Ethernet environment, the M/E-ISW-FX-02 Series media converters extend network distances by segmenting collision domains so that the 512-Bit Rule applies separately to each collision domain.
- In a full-duplex Ethernet or Fast Ethernet environment, the M/E-ISW-FX-02 Series media converters extend network distances to the physical cable limitations imposed by the selected twisted-pair copper fiber cables.

Far-End Fault

When a fault occurs on an incoming fiber link (1), the media converter transmits a Far-End Fault signal on the outgoing fiber link (2). In addition, the Far-End Fault signal also activates the Link Pass-Through, which in turn, disables the link on the copper portion of the network (3) and (4).

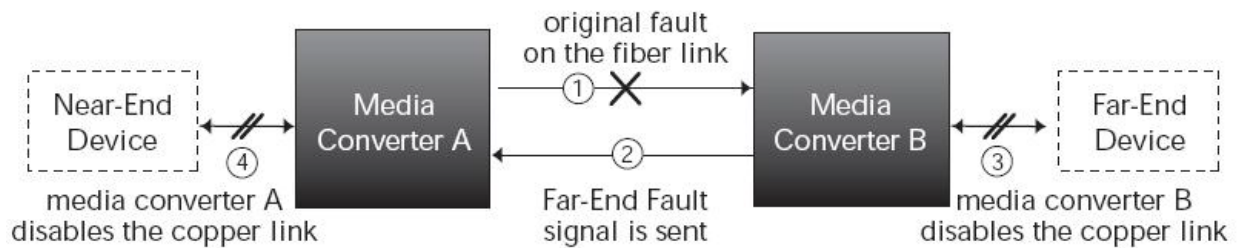

Optic and Cable Specifications

The fiber optic cable physical characteristics must meet or exceed IEEE 802.3ae specification.

Fiber cable

Bit Error Rate:	<10 ⁻⁹
Single mode fiber (<i>recommended</i>):	9 μm
Multimode fiber (<i>recommended</i>):	62.5/125 μm
Multimode fiber (<i>optional</i>):	100/140, 85/140, 50/125 μm

Optics

M/E-ISW-FX-02 Series	1310 nm multimode	
Fiber Optic Transmitter Power:	min: -19.0 dBm	max: -14.0 dBm
Fiber Optic Receiver Sensitivity:	min: -33.0 dBm	max: -12.0 dBm
Link Budget:	14.0 dB	
M/E-ISW-FX-02 Series (MMLC)	1310 nm multimode	
Fiber-optic Transmitter Power:	min: -19.0 dBm	max: -12.0 dBm
Fiber-optic Receiver Sensitivity:	min: -30.0 dBm	max: -8.0 dBm
Link Budget:	11.0 dB	
M/E-ISW-FX-02 Series (SC)	1310 nm multimode	
Fiber-optic Transmitter Power:	min: -19.0 dBm	max: -14.0 dBm
Fiber-optic Receiver Sensitivity:	min: -33.0 dBm	max: -12.0 dBm
Link Budget:	14.0 dB	
M/E-ISW-FX-02 Series (SM)	1310 nm single mode	
Fiber Optic Transmitter Power:	min: -15.0 dBm	max: -8.0 dBm
Fiber Optic Receiver Sensitivity:	min: -34.0 dBm	max: -3.0 dBm
Link Budget:	19.0 dB	

Copper Cable

Category 3: (Minimum requirement for 10 Mb/s operation)

Gauge	24 to 22 AWG
Attenuation	11.5 dB/100m @ 5-10 MHz
Maximum Cable Distance	100 meters

Category 5: (Minimum requirement for 100 Mb/s operation)

Gauge	24 to 22 AWG
Attenuation	22.0 dB /100m @ 100 MHz
Maximum Cable Distance	100 meters

- Straight-through or crossover twisted-pair cable may be used.
- Shielded (STP) or unshielded (UTP) twisted-pair cable may be used.
- Pins 1&2 and 3&6 are the two active pairs in an Ethernet network.
- Use only dedicated wire pairs for the active pins:
(e.g., blue/white & white/blue, orange/white & white/orange, etc.)
- Do not use flat or silver satin wire.

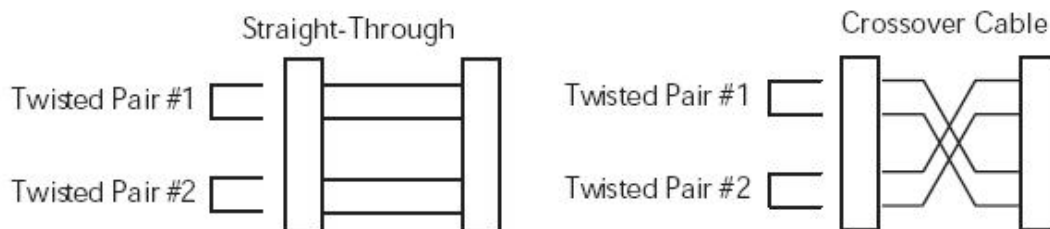

CAUTION: Copper based media ports, e.g., Twisted Pair (TP) Ethernet, USB, RS232, RS422, RS485, DS1, DS3, Video Coax, etc., are intended to be connected to intrabuilding (inside plant) link segments that are not subject to lightening transients or power faults. Copper-based media ports, e.g., Twisted Pair (TP) Ethernet, USB, RS232, RS422, RS485, DS1, DS3, Video Coax, etc., are NOT to be connected to interbuilding (outside plant) link segments that are subject to lightening transients or power faults. Failure to observe this caution could result in damage to equipment.

Technical Specifications

For use with Lantronix Model M/E-ISW-FX-02 Series converters.

Data rate:	10 Mb/s, 100 Mb/s
Dimensions:	1.8"W x 3.3"D x 0.85"H (46 x 85 x 22 mm)
Weight:	2 lbs. (0.90 kg) approximately
Power consumption:	2.5 typical (3.3 watts max)
MTBF*:	Greater than 41,680 hours (MIL-HDBK-217F) Greater than 114,580 hours (Bellcore7 V5.0)
Unicast MAC addresses:	1K
Maximum packet size:	2046 bytes (10,240 bytes on SFP version)
Power sources:	12 - 48 VDC or 24-36 VAC \pm 10%
Operating temp:	-40°C to +75°C (-40°F to +167°F)
Storage temp:	-40°C to +85°C (-40°F to +185°F)
Humidity:	5% to 95%, non-condensing
Warranty:	Lifetime

* MTBF calculation is based on use with a 50,000 hour power supply.

WARNING: Visible and invisible laser radiation when open. Do not stare into the beam or view directly with optical instruments. Failure to observe this warning could result in an eye injury or blindness.

WARNING: Use of controls, adjustments, or the performance of procedures other than those specified herein could result in hazardous radiation exposure.

Application Example

The figure below shows a sample M/E-ISW-FX-02 configuration with a security camera.

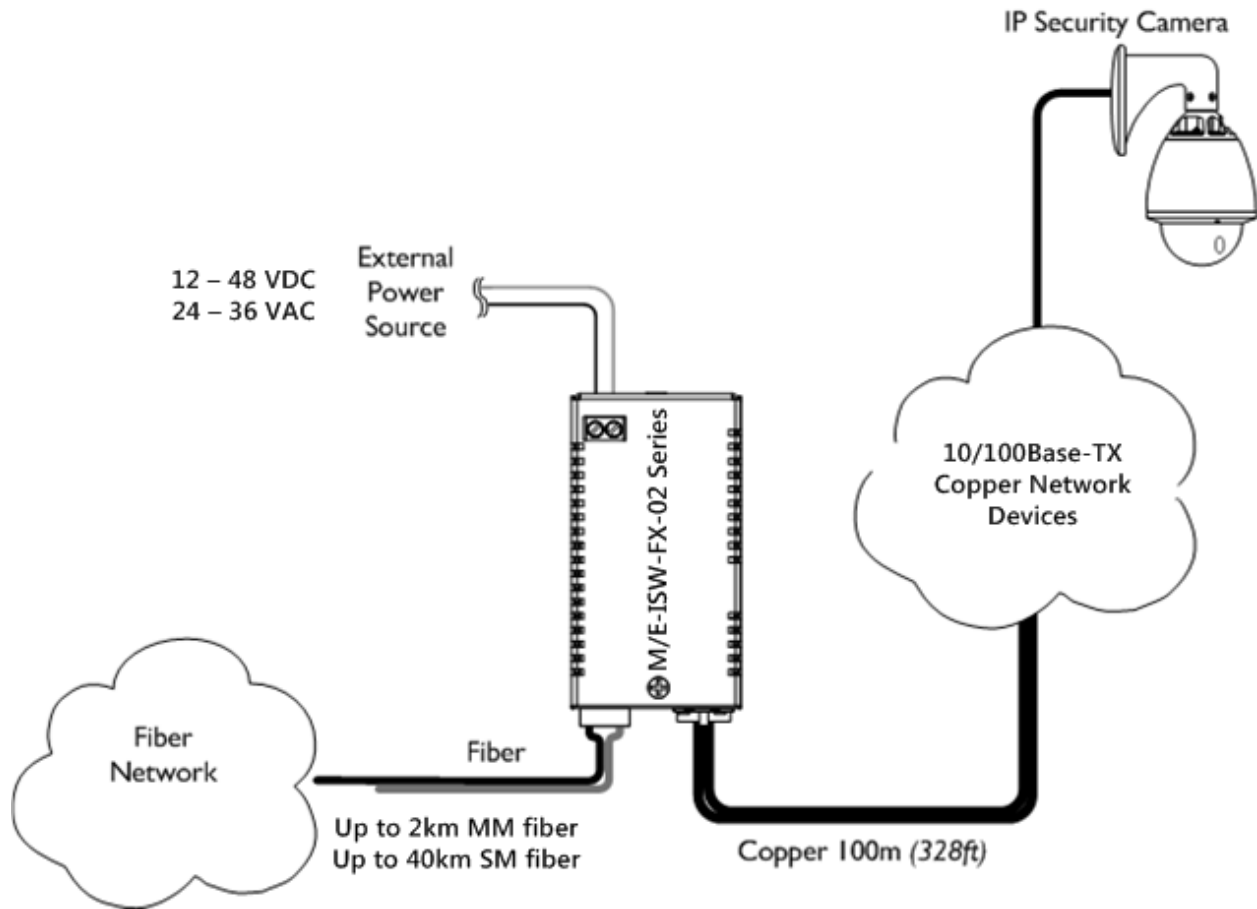

Troubleshooting

If the media converter fails, isolate and correct the fault by answering the following questions and then taking the indicated action:

1. Is the PWR (power) LED lit?
NO
 - Is the power adapter the proper type of voltage and cycle frequency for the AC outlet?
 - Is the power adapter properly installed in the media converter and in the outlet?
 - Contact Tech Support. See [Contact Us](#).YES
 - Proceed to step 2.
2. Is the RXC (copper link) LED lit?
NO
 - Check the twisted-pair copper cables for proper connection.
 - Contact Tech Support. See [Contact Us](#).YES
 - Proceed to step 3.
3. Is the LKF (fiber link) LED lit?
NO
 - Check the fiber cables for proper connection.
 - Verify that the TX and RX cables on the media converter are connected to the RX and TX ports, respectively, on the other device.
 - If the media converter is connected to another M/E-ISW-FX-02 Series using fiber, verify the fiber Auto Negotiate is disabled.
 - Contact Tech Support. See [Contact Us](#).YES
 - Proceed to step 4.
4. Is the RXC (copper receive) LED flashing?
NO
 - If there is activity on the 1000Base-T port, disconnect and reconnect the twisted-pair copper cable to restart the initialization process.
 - Restart the workstation to restart the initialization process.
 - Contact Tech Support. See [Contact Us](#).YES
 - Contact Tech Support. See [Contact Us](#).

Contact Us

- Lantronix website : <https://www.lantronix.com>
- Product Index : <https://www.lantronix.com/resources/product-index/>
- Application Notes : <https://www.lantronix.com/resources/app-notes/>
- Tech Support : Tel: +1 (800) 526-8766 or <https://www.lantronix.com/technical-support/>
- Contact Us : <https://www.lantronix.com/about-us/contact/>

Note that this manual may provide links to third party websites for which Lantronix is not responsible.

Compliance Information

Declaration of Conformity

Manufacture's Name: Lantronics, Inc.

Manufacture's Address: 48 Discovery, Suite 250, Irvine, California 92618 USA

Declares that the products:

M/E-ISW-FX-02(SFP), M/E-ISW-FX-02, M/E-ISW-FX-02(SC),

M/E-ISW-FX-02(SM), M/E-ISW-FX-02(MMLC)

Conform to the following Product Regulations:

Electromagnetic Compatibility (EMC) Directive 2014/30/EU;

Low-Voltage Directive (LVD) 2014/35/EU; EN 55022:2010, EN 55024:2010,

EN 60950-1:2006

With the technical construction on file at the above address, this product carries the CE Mark

I, the undersigned, hereby declare that the equipment specified above conforms to the above Directive(s) and Standard(s).

Place: Irvine, California

Date: April 27, 2022

Signature: *Eric Bass*

Full Name: Eric Bass

Position: Vice President of Engineering

FCC Regulations

This equipment has been tested and found to comply with the limits for a Class A digital device, pursuant to Part 15 of the FCC rules. These limits are designed to provide reasonable protection against harmful interference when the equipment is operated in a commercial environment. This equipment generates, uses and can radiate radio frequency energy and, if not installed and used in accordance with the instruction manual, may cause harmful interference to radio communications.

Operation of this equipment in a residential area is likely to cause harmful interference, in which case the user will be required to correct the interference at the user's own expense.

Canadian Regulations

This digital apparatus does not exceed the Class A limits for radio noise for digital apparatus set out on the radio interference regulations of the Canadian Department of Communications.

Le présent appareil numérique n'émet pas de bruits radioélectriques dépassant les limites applicables aux appareils numériques de la Class A prescrites dans le Règlement sur le brouillage radioélectrique édicté par le ministère des Communications du Canada.

European Regulations

Warning

This is a Class A product. In a domestic environment this product may cause radio interference in which case the user may be required to take adequate measures.

Achtung !

Dieses ist ein Gerät der Funkstörgrenzwertklasse A. In Wohnbereichen können bei Betrieb dieses Gerätes Rundfunkstörungen auftreten. In diesem Fall ist der Benutzer für Gegenmaßnahmen verantwortlich.

Attention !



Ceci est un produit de Classe A. Dans un environnement domestique, ce produit risque de créer des interférences radioélectriques, il appartiendra alors à l'utilisateur de prendre les mesures spécifiques appropriées.

In accordance with European Union Directive 2002/96/EC of the European Parliament and of the Council of 27 January 2003, Lantronix will accept post usage returns of this product for proper disposal. The contact information for this activity can be found in the 'Contact Us' portion of this document.



CAUTION: RJ connectors are NOT INTENDED FOR CONNECTION TO THE PUBLIC TELEPHONE NETWORK. Failure to observe this caution could result in damage to the public telephone network.

Der Anschluss dieses Gerätes an ein öffentliches Telekommunikationsnetz in den EGMitgliedstaaten verstösst gegen die jeweiligen einzelstaatlichen Gesetze zur Anwendung der Richtlinie 91/263/EWG zur Angleichung der Rechtsvorschriften der Mitgliedstaaten über Telekommunikationsendeinrichtungen einschliesslich der gegenseitigen Anerkennung ihrer Konformität.

**Lantronix Corporate Headquarters**

48 Discovery, Suite 250
Irvine, CA 92618, USA
Toll Free: 800-526-8766
Phone: 949-453-3990
Fax: 949-453-3995

Technical Support

<https://www.lantronix.com/technical-support/>

Sales Offices

For a current list of our domestic and international sales offices, go to the Lantronix web site at www.lantronix.com/about/contact.