



TN-QSFP-100G-xxxxx  
Transceiver Modules  
User Guide

**Part Number 33765**  
**Revision C February 2022**

## Intellectual Property

© 2022 Lantronix, Inc. All rights reserved. No part of the contents of this publication may be transmitted or reproduced in any form or by any means without the written permission of Lantronix.

*Lantronix* is a registered trademark of Lantronix, Inc. in the United States and other countries.

All other trademarks and trade names are the property of their respective holders.

Patented: <https://www.lantronix.com/legal/patents/>; additional patents pending.

## Warranty

For details on the Lantronix warranty policy, please go to our web site at

<http://www.lantronix.com/support/warranty>.

## Contacts

### Lantronix Corporate Headquarters

7535 Irvine Center Drive

Suite100

Irvine, CA 92618, USA

Toll Free: 800-526-8766

Phone: 949-453-3990

Fax: 949-453-3995

### Technical Support

Phone: +1.952.358.3601 or 1.800.260.1312

Email: [techsupport@transition.com](mailto:techsupport@transition.com)

### Sales Offices

For a current list of our domestic and international sales offices, go to the Lantronix web site at

[www.lantronix.com/about/contact](http://www.lantronix.com/about/contact).

## Disclaimer

All information contained herein is provided "AS IS." Lantronix undertakes no obligation to update the information in this publication. Lantronix does not make, and specifically disclaims, all warranties of any kind (express, implied or otherwise) regarding title, non-infringement, fitness, quality, accuracy, completeness, usefulness, suitability or performance of the information provided herein. Lantronix shall have no liability whatsoever to any user for any damages, losses and causes of action (whether in contract or in tort or otherwise) in connection with the user's access or usage of any of the information or content contained herein. The information and specifications contained in this document are subject to change without notice.

## Revision History

Date	Rev	Comments
8/30/18	A	Initial release.
4/14/20	B	Update TN-QSFP-100G-LR4 and TN-QSFP-100G-SR4 pull latch, unlocking structure, and packaging.
1/13/22	C	Initial Lantronix re-brand.



## Table of Contents

Product Description .....	4
Ordering Information .....	4
Features .....	4
Specifications .....	4
SFP Dimensions .....	5
Optical Specifications .....	6
Applications: Fiber Connections with SFPs .....	6
SFP Unpacking .....	6
SFP Installation .....	6
Cautions .....	6
Installing the TN-QSFP-100G-xxxxx .....	6
Fiber Cable Physical Characteristics .....	8
Cleaning .....	8
Attaching the Optical Network Cable .....	9
Removing the TN-QSFP-100G-xxxxx .....	9
CLI Command output: “show version” and “show interface transceiver details” .....	10
For More Information .....	12
Compliance Information .....	13

## Product Description

The Lantronix TN-QSFP-100G Series QSFP28 optical transceivers are hot-swappable pluggables that can be installed in any QSFP28 port for 100 Gigabit Ethernet connections. The new generation of 100G transceiver solutions are compliant with the IEEE 802.3bm standard and offer a wide selection of high-density, compact footprint and low-power 100G Ethernet connectivity options.

## Ordering Information

Model	Description
 <b>TN-QSFP-100G-SR4</b>	QSFP28 100GBase-SR4, 850nm multimode (MPO) [100 m/328 ft. on OM4] [70 m/229 ft. on OM3] with DMI. Link Budget: 2.3 dB.
 <b>TN-QSFP-100G-LR4</b>	QSFP28 100GBase-LR4, 1295nm, 1300nm, 1304nm, 1309nm, single mode (LC); [10 km/6.2 mi.] with DMI. Link Budget: 6.3 dB.
 <b>TN-QSFP-100G-CWDM4</b>	QSFP28 100GBase-LR4, 1295nm, 1300nm, 1304nm, 1309nm, single mode (LC); [2 km/1.2 mi.] with DMI. Link Budget: 6.3 dB.

## Features

- Hot-pluggable QSFP28 form factor
- High capacity: up to 103.1 Gbps
- QSFP28 MSA Compliant
- Single 3.3V Power Supply
- Power dissipation < 3.5 Watts
- RoHS Compliant (all models)
- Digital Diagnostic Monitoring (DDM)
- Class 1 Laser International Safety
- Standard IEC 60825 compliant
- 100GBase-SR4: 4 x 25 Gbps, 850nm, Multimode, 100 m over OM4, MPO
- 100GBase-LR4: 4 x 25 Gbps, WDM wavelength, Single Mode, 10 km, Duplex LC
- 100GBase-CWDM4 MSA: 4 x 25Gbps, WDM wavelength, Single Mode, 2 km, Duplex LC

## Specifications

The Lantronix QSFP28 modules fully comply with the Multi-Sourcing Agreement (MSA). This compliance allows our QSFP28 modules to be used in all other MSA compliant QSFP28 platforms. In addition, Lantronix QSFP28 modules are also Compliant with all Cisco QSFP28 based routers and switches, as well as Cisco's IOS software. Lantronix QSFP28 modules ARE NOT Cisco OEM brand modules.

The TN-QSFP-100G-xxxx was designed to meet these standards and specifications:

<b>Standards</b> (TN-QSFP-100G-SR4, TN-QSFP-100G-LR4, and TN-QSFP-100G-PSM4)	IEEE 802.3bm and SFF 8436. ROHS 6 compliant (TN-QSFP-100G-PSM4). ROHS compliant (TN-QSFP-100G-SR4 and TN-QSFP-100G-LR4)
<b>Standards</b> (TN-QSFP-100G-CWDM4)	Compliant with QSFP28 MSA, CWDM4 MSA and portions of IEEE 802.3bm. ROHS 6 compliant.
<b>Compliance</b>	IEC 60825-1, FDA CDRH 21-CFR 1040.10 Class 1
<b>Dimensions</b>	Width: 0.71" [18 mm] x Depth: 2.83" [72 mm] x Height: 0.33" [8.5 mm] (see below)
<b>Power Input</b>	3.3V
<b>Power Consumption</b>	< 3.5 Watts
<b>Operating Temp</b>	0°C to +70°C
<b>Storage Temp</b>	-40°C to +85°C
<b>Warranty</b>	Lifetime

## SFP Dimensions

The TN-QSFP-100G-CWDM4 dimensions are shown below.

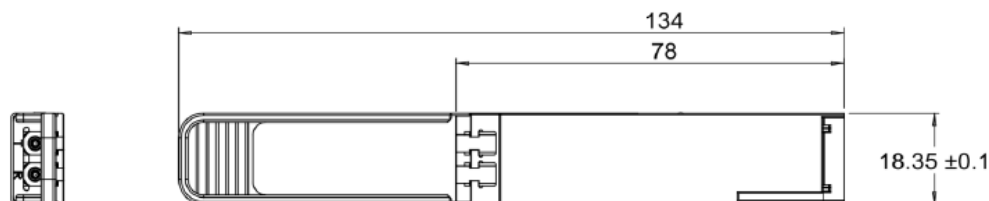

Modified TN-QSFP-100G-LR4 and TN-QSFP-100G-SR4 pull latch and unlocking structure (April 2020):

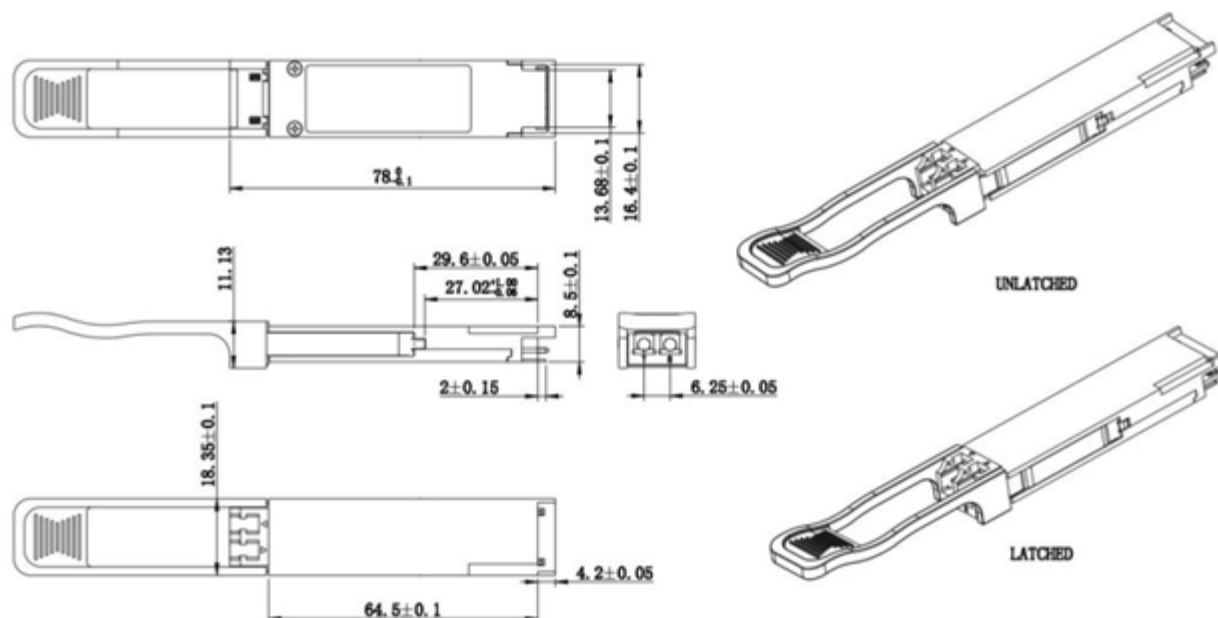

## Optical Specifications

The Optical Spec for all Lantronix SFPs are listed at [www.transition.com/sfp.pdf](http://www.transition.com/sfp.pdf).

## Applications: Fiber Connections with SFPs

SFP applications include 100G Data Center connectivity, 100G Aggregation and Backplane applications, 100Gbase-X Ethernet, etc. The TN-QSFP-100G-CWDM4 can be used in a 100G CWDM4 application with FEC.

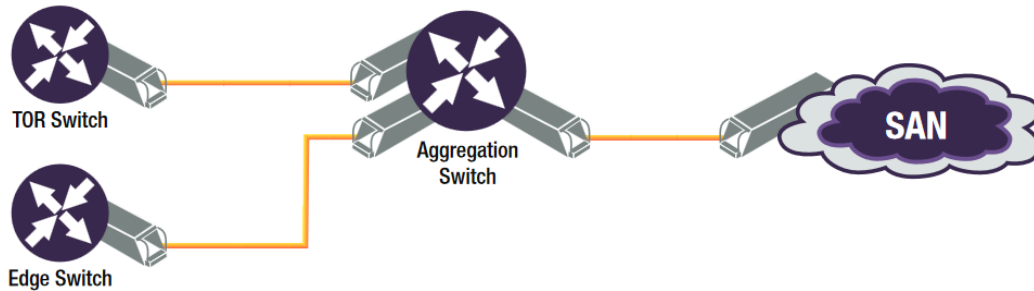

## SFP Unpacking

Before you start installing the TN-QSFP-100G-xxxxx, verify that the package contains these items:

- One TN-QSFP-100G-xxxxx
- One Documentation Postcard

Please notify your sales representative immediately if any of the above items is missing or damaged. Save the packaging for possible future use.

## SFP Installation

### Cautions

- The SFP transceiver module is keyed to only be installed one way. However, if forced the wrong way, damage may occur.
- Avoid getting dust or other contaminants into the fiber bore of the SFP transceiver module, as this will cause the optics to not operate properly.
- Clean the optic surfaces of the optical fiber before you plug them back in to the optical bores of another SFP transceiver module.
- Each port must match the wavelength specifications on the other end of the cable, and the cable must not exceed the specified cable length for reliable communications.

### Installing the TN-QSFP-100G-xxxxx

The TN-QSFP-100G-xxxxx is used primarily in short reach applications in switches, routers, and data center equipment where it provides higher density than SFP+ modules.

**Note:** The multiple-fiber push-on (MPO) connectors and the duplex LC connectors on the TN-QSFP-100G-xxxxx support network interface cables with either Physical Contact (PC) or Ultra-Physical Contact (UPC) flat-polished face types. The MPO connectors and the duplex LC connectors on the TN-QSFP-100G-xxxxx do not support network interface cables with an angle-polished contact (APC) face type.

**Warning:** Invisible laser radiation may be emitted from the aperture of the port when no cable is connected; avoid exposure to laser radiation and do not stare into open apertures.

**Warning:** Ultimate disposal of this product must be handled according to all national laws and regulations.

**Warning:** Use of controls, adjustments, or performing procedures other than those specified may result in hazardous radiation exposure.

## Tools Needed

These tools are needed to install the TN-QSFP-100G-xxxxx:

- Wrist strap or other personal grounding device to prevent ESD occurrences.
- Antistatic mat or antistatic foam to set the TN-QSFP-100G-xxxxx on.
- Fiber-optic end-face cleaning tools and inspection equipment.

## Installation Procedure

**Caution:** The TN-QSFP-100G-xxxxx is a static-sensitive device. Always use an ESD wrist strap or similar individual grounding device when handling or coming into contact with a TN-QSFP-100G-xxxxx.

The TN-QSFP-100G-xxxxx has a bail-clasp latch. To install a TN-QSFP-100G-xxxxx, follow these steps:

1. Attach an ESD wrist strap to yourself and a properly grounded point on the chassis or the rack.
2. Remove the TN-QSFP-100G-xxxxx from its protective packaging.
3. Check the label on the TN-QSFP-100G-xxxxx body to verify that you have the correct model for your network.
4. Remove the optical bore dust plug and set it aside.
5. Keep the bail-clasp aligned in a vertical position.
6. Align the TN-QSFP-100G-xxxxx in front of the module's transceiver socket opening and carefully slide the TN-QSFP-100G-xxxxx into the socket until the TN-QSFP-100G-xxxxx makes contact with the socket electrical connector.
7. Press firmly on the front of the TN-QSFP-100G-xxxxx with your thumb to fully seat the TN-QSFP-100G-xxxxx in the TN-QSFP-100G-xxxxx socket.

**Caution:** If the latch is not fully engaged, you could accidentally disconnect the TN-QSFP-100G-xxxxx.

8. Reinstall the dust plug into the TN-QSFP-100G-xxxxx optical bore until you are ready to attach the network interface cable. Do not remove the dust plug until you are ready to attach the network interface cable.

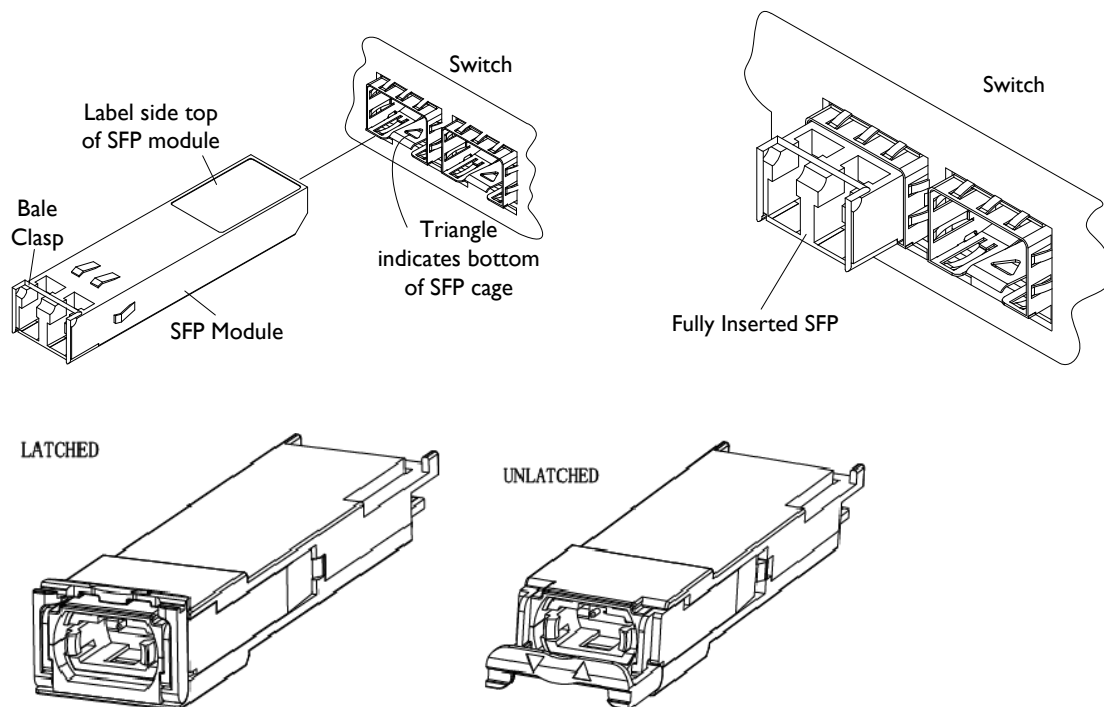

## Fiber Cable Physical Characteristics

The fiber cable physical characteristics must meet or exceed IEEE 802.3bm specifications.

**TN-QSFP-100G-SR4:** OM3 Multimode Fiber (up to 70m on) or OM4 Multimode fiber (up to 100m).

**TN-QSFP-100G-LR4:** 100G QSFP28 Duplex LC connector; up to 10km transmission on SMF, with DOM (Digital Optical Monitoring) function.

**TN-QSFP-100G-PSM4:** designed to operate over single mode fiber systems using 1310nm DFB laser array. An optical fiber ribbon cable with an MPO/MTPMT connector can be plugged into the TN-QSFP-100G-PSM4 module receptacle.

**TN-QSFP-100G-CWDM4:** designed to operate over single mode fiber systems using 1310nm DFB laser array.

**ISO/IEC 11801** (Structured Cabling): International standard ISO/IEC 11801 Information technology — Generic cabling for customer premises specifies general-purpose telecommunication cabling systems (structured cabling) that are suitable for a wide range of applications (analog and ISDN telephony, various data communication standards, building control systems, factory automation). It covers both balanced copper cabling and optical fibre cabling. The standard was designed for use within commercial premises that may consist of either a single building or of multiple buildings on a campus. It was optimized for premises that span up to 3 km, up to 1 km<sup>2</sup> office space, with between 50 and 50,000 persons, but can also be applied for installations outside this range. A major revision, Edition 3, was released in November 2017, unifying requirements for commercial, home and industrial networks.

The standard defines several classes of optical fiber interconnect:

OM1: Multimode fiber type 62.5 µm core; minimum modal bandwidth of 200 MHz·km at 850 nm

OM2: Multimode fiber type 50 µm core; minimum modal bandwidth of 500 MHz·km at 850 nm

OM3: Multimode fiber type 50 µm core; minimum modal bandwidth of 2000 MHz·km at 850 nm

OM4: Multimode fiber type 50 µm core; minimum modal bandwidth of 4700 MHz·km at 850 nm

## Cleaning

It is important that every fiber connector be inspected and cleaned prior to mating. Numerous tools and cleaning products are available for cleaning with a fiber cleaner for the fiber head as well as for cleaning with a ferrule cleaner. Cleaning products can include cartridge and pocket style cleaners, lint-free wipes, lint-free swabs, lint-free wet wipes, lint-free swabs, manual advance cleaners, etc. from a wide array of vendors.

This section is provided as a general guideline and not as a complete process or procedure, as no known cleaning method is 100% effective. Dirt is the single biggest problem with fiber optics. Inspect and clean connectors. Inspect and clean again until they are perfect. Inspect and clean both ends in pairs. Clean the connectors, the mating adapters, and the transceiver ports.

Have a cleaning policy in place including a checklist of items tailored to your specific site requirements. Keep records for future troubleshooting (e.g., where cable is run, splice and termination locations, make and model of components, OTDR data, cleaning performed, etc.).

**Follow industry safety precautions!** **Warning:** Invisible laser radiation might be emitted from disconnected fibers or connectors. Do not stare into beams directly or view with optical instruments. **Always** turn off any laser sources before you inspect fiber connectors, optical components, or bulkheads. **Always** make sure that the cable is disconnected at both ends or that pluggable transceiver is removed from the device. **Always** wear the appropriate safety glasses when required for your area. **Never** look into a fiber with the device lasers on. **Always** follow proper grounding procedures. **Never** connect a fiber to a fiberscope with the device lasers on.

**Warning:** Visible and invisible laser radiation when open. DO NOT stare into laser beam or view directly with optical instruments. Failure to observe this warning could result in damage to your eyes or blindness.



## Attaching the Optical Network Cable

Before removing the dust plugs and making any optical connections, follow these guidelines:

- Keep the protective dust plugs installed in the unplugged fiber-optic cable connectors and in the transceiver optical bores until you are ready to make a connection.
- Inspect and clean the MPO connector or the duplex LC connector end faces just before you make any connections.
- Grasp the MPO or the duplex LC connector only by the connector housing to plug or unplug a fiber-optic cable.

**Note:** The MPO connectors on the TN-QSFP-40G-SR4 are keyed to prevent incorrect insertion.

**Note:** The multiple-fiber push-on (MPO) connectors and the duplex LC connectors on the TN-QSFP-100G-xxxxx support network interface cables with either Physical contact (PC) or Ultra-Physical Contact (UPC) flat-polished face types. The MPO connectors and the duplex LC connectors on the TN-QSFP-100G-xxxxx do not support network interface cables with an angle-polished contact (APC) face type.

1. Remove the dust plugs from the optical network interface cable MPO connectors. Save the dust plugs for future use.
2. Inspect and clean the MPO or duplex LC connector's fiber-optic end faces.
3. Remove the dust plugs from the TN-QSFP-100G-xxxxx optical bores.
4. Immediately attach the network interface cable MPO connector or duplex LC connector to the TN-QSFP-100G-xxxxx.
5. Verify that the optical network cable is fully seated by pulling gently on the cable's MPO or duplex LC connector boot. If the network cable disconnects, reinstall it and make sure that the cable connector is fully seated and that the connector latch engages.

## Removing the TN-QSFP-100G-xxxxx

**Caution:** Be careful when removing the SFP or SFP+ from a device. Some SFP transceiver module temperatures may exceed 160°F (70°C) and be too hot to touch with bare hands. **Note:** Do not remove and replace the SFP modules more often than necessary; excessive SFP removing and replacing can shorten the SFPs useful life.

**Caution:** The TN-QSFP-100G-xxxxx is a static-sensitive device. Always use an ESD wrist strap or similar individual grounding device when handling or coming into contact with a TN-QSFP-100G-xxxxx.

To remove a QSFP+ transceiver, follow these steps:

1. Disconnect the network interface cable from the TN-QSFP-100G-xxxxx.
2. Pivot the bail-clasp down to the horizontal position.
3. Immediately install the dust plug into the transceivers optical bore.
4. Grasp the sides of the QSFP+ transceiver and slide it out of the module socket.
5. Place the TN-QSFP-100G-xxxxx into an antistatic bag.

## CLI Command output: “show version” and “show interface transceiver details”

Cisco Nexus9000 93180YC-EX chassis with TN-QSFP-100G-LR4:

```
[2018-05-24 20:47:49.992] show version
[2018-05-24 20:47:51.368] Cisco Nexus Operating System (NX-OS) Software
[2018-05-24 20:47:51.416] TAC support: http://www.cisco.com/tac
[2018-05-24 20:47:51.447] Copyright (C) 2002-2016, Cisco and/or its affiliates.
[2018-05-24 20:47:51.510] All rights reserved.
[2018-05-24 20:47:51.526] The copyrights to certain works contained in this software are
[2018-05-24 20:47:51.592] owned by other third parties and used and distributed under their own
[2018-05-24 20:47:51.672] licenses, such as open source. This software is provided "as is," and unless
[2018-05-24 20:47:51.751] otherwise stated, there is no warranty, express or implied, including but not
[2018-05-24 20:47:51.831] limited to warranties of merchantability and fitness for a particular purpose.
[2018-05-24 20:47:51.927] Certain components of this software are licensed under
[2018-05-24 20:47:51.975] the GNU General Public License (GPL) version 2.0 or
[2018-05-24 20:47:52.038] GNU General Public License (GPL) version 3.0 or the GNU
[2018-05-24 20:47:52.086] Lesser General Public License (LGPL) Version 2.1 or
[2018-05-24 20:47:52.152] Lesser General Public License (LGPL) Version 2.0.
[2018-05-24 20:47:52.200] A copy of each such license is available at
[2018-05-24 20:47:52.251] http://www.opensource.org/licenses/gpl-2.0.php and
[2018-05-24 20:47:52.311] http://opensource.org/licenses/gpl-3.0.html and
[2018-05-24 20:47:52.358] http://www.opensource.org/licenses/lgpl-2.1.php and
[2018-05-24 20:47:52.409] http://www.gnu.org/licenses/old-licenses/library.txt.
[2018-05-24 20:47:52.470]
[2018-05-24 20:47:52.470] Software
[2018-05-24 20:47:52.491]   BIOS: version 07.45
[2018-05-24 20:47:52.502]   NXOS: version 7.0(3)I4(2)
[2018-05-24 20:47:52.535]   BIOS compile time: 12/04/2015
[2018-05-24 20:47:52.568]   NXOS image file is: bootflash:///nxos.7.0.3.I4.2.bin
[2018-05-24 20:47:52.632]   NXOS compile time: 7/21/2016 8:00:00 [07/21/2016 16:09:32]
[2018-05-24 20:47:52.693]
[2018-05-24 20:47:52.693] Hardware
[2018-05-24 20:47:52.709]   cisco Nexus9000 93180YC-EX chassis
[2018-05-24 20:47:52.747]   Intel(R) Xeon(R) CPU @ 1.80GHz with 24634044 kB of memory.
[2018-05-24 20:47:52.823]   Processor Board ID FD020270CU1
[2018-05-24 20:47:52.857]
[2018-05-24 20:47:52.857]   Device name: switch
[2018-05-24 20:47:52.872]   bootflash: 53298520 kB
[2018-05-24 20:47:52.905] Kernel uptime is 0 day(s), 12 hour(s), 3 minute(s), 10 second(s)
[2018-05-24 20:47:52.986]
[2018-05-24 20:47:52.986] Last reset
[2018-05-24 20:47:52.986]   Reason: Unknown
[2018-05-24 20:47:53.017]   System version: 7.0(3)I4(2)
[2018-05-24 20:47:53.050]   Service:
[2018-05-24 20:47:53.063]
[2018-05-24 20:47:53.063] plugin
[2018-05-24 20:47:53.063]   Core Plugin, Ethernet Plugin
[2018-05-24 20:47:53.095]
[2018-05-24 20:47:53.095] Active Package(s):
[2018-05-24 20:47:53.126] switch# show inventory
[2018-05-24 20:48:01.569] NAME: "Chassis", DESCR: "Nexus9000 93180YC-EX chassis"
[2018-05-24 20:48:01.650] PID: N9K-C93180YC-EX , VID: V01 , SN: FD020270CU1
[2018-05-24 20:48:01.714]
[2018-05-24 20:48:01.714] NAME: "Slot 1", DESCR: "48x10/25G + 6x40/100G Ethernet Module"
[2018-05-24 20:48:01.794] PID: N9K-C93180YC-EX , VID: V01 , SN: FD020270CU1
[2018-05-24 20:48:01.858]
[2018-05-24 20:48:01.858] NAME: "Power Supply 1", DESCR: "Nexus9000 93180YC-EX chassis Power Supply"
[2018-05-24 20:48:01.938] PID: NXA-PAC-650W-PI , VID: V01 , SN: LIT201605A5
[2018-05-24 20:48:02.005]
[2018-05-24 20:48:02.017] NAME: "Power Supply 2", DESCR: "Nexus9000 93180YC-EX chassis Power Supply"
[2018-05-24 20:48:02.097] PID: NXA-PAC-650W-PI , VID: V01 , SN: LIT201605A6
[2018-05-24 20:48:02.162]
[2018-05-24 20:48:02.162] NAME: "Fan 1", DESCR: "Nexus9000 93180YC-EX chassis Fan Module"
```

```

[2018-05-24 20:48:02.226] PID: NXA-FAN-30CFM-B , VID: V01 , SN: N/A
[2018-05-24 20:48:02.306]
[2018-05-24 20:48:02.306] NAME: "Fan 2", DESCR: "Nexus9000 93180YC-EX chassis Fan Module"
[2018-05-24 20:48:02.370] PID: NXA-FAN-30CFM-B , VID: V01 , SN: N/A
[2018-05-24 20:48:02.434]
[2018-05-24 20:48:02.449] NAME: "Fan 3", DESCR: "Nexus9000 93180YC-EX chassis Fan Module"
[2018-05-24 20:48:02.514] PID: NXA-FAN-30CFM-B , VID: V01 , SN: N/A
[2018-05-24 20:48:02.578]
[2018-05-24 20:48:02.578] NAME: "Fan 4", DESCR: "Nexus9000 93180YC-EX chassis Fan Module"
[2018-05-24 20:48:02.658] PID: NXA-FAN-30CFM-B , VID: V01 , SN: N/A
[2018-05-24 20:48:02.722]
[2018-05-24 20:48:02.722] switch# show interface ethernet 1/49 capabilities
[2018-05-24 20:48:12.796] Ethernet1/49
[2018-05-24 20:48:12.813] Model: N9K-C93180YC-EX
[2018-05-24 20:48:12.846] Type (SFP capable): QSFP-100G-LR4
[2018-05-24 20:48:12.893] Speed: 1000,10000,25000,40000,50000,100000
[2018-05-24 20:48:12.957] Duplex: full
[2018-05-24 20:48:12.988] Trunk encap. type: 802.1Q
[2018-05-24 20:48:13.020] Channel: yes
[2018-05-24 20:48:13.052] Broadcast suppression: percentage(0-100)
[2018-05-24 20:48:13.101] Flowcontrol: rx-(off/on),tx-(off/on)
[2018-05-24 20:48:13.149] Rate mode: dedicated
[2018-05-24 20:48:13.197] Port mode: Routed,Switched
[2018-05-24 20:48:13.229] QoS scheduling: rx-(8q2t),tx-(7q)
[2018-05-24 20:48:13.277] CoS rewrite: yes
[2018-05-24 20:48:13.308] ToS rewrite: yes
[2018-05-24 20:48:13.341] SPAN: yes
[2018-05-24 20:48:13.372] UDLD: yes
[2018-05-24 20:48:13.404] MDIX: no
[2018-05-24 20:48:13.436] TDR capable: no
[2018-05-24 20:48:13.469] Link Debounce: yes
[2018-05-24 20:48:13.501] Link Debounce Time: yes
[2018-05-24 20:48:13.533] FEX Fabric: no
[2018-05-24 20:48:13.565] dot1Q-tunnel mode: yes
[2018-05-24 20:48:13.600] Pvlan Trunk capable: no
[2018-05-24 20:48:13.611] Port Group Members: 193
[2018-05-24 20:48:13.644] EEE (efficient-eth): no
[2018-05-24 20:48:13.677] PFC capable: yes
[2018-05-24 20:48:13.710] Buffer Boost capable: no
[2018-05-24 20:48:13.740] Breakout capable: yes
[2018-05-24 20:48:13.772]
[2018-05-24 20:48:13.772] switch# show interface ethernet 1/49 transceiver details
[2018-05-24 20:48:21.080] Ethernet1/49
[2018-05-24 20:48:21.097] transceiver is present
[2018-05-24 20:48:21.129] type is QSFP-100G-LR4
[2018-05-24 20:48:21.145] name is TRANSITION
[2018-05-24 20:48:21.176] part number is TN-QSFP-100G-LR4
[2018-05-24 20:48:21.225] revision is 1A
[2018-05-24 20:48:21.243] serial number is TN02000237
[2018-05-24 20:48:21.288] nominal bitrate is 25500 MBit/sec per channel
[2018-05-24 20:48:21.336] Link length supported for 9/125um fiber is 10 km
[2018-05-24 20:48:21.385] cisco id is 17
[2018-05-24 20:48:21.442] cisco extended id number is 252
[2018-05-24 20:48:21.495]
[2018-05-24 20:48:21.495] Lane Number:1 Network Lane
[2018-05-24 20:48:21.497] SFP Detail Diagnostics Information (internal calibration)
[2018-05-24 20:48:21.563] -----
[2018-05-24 20:48:21.640] Current Alarms Warnings
[2018-05-24 20:48:21.721] Measurement High Low High Low
[2018-05-24 20:48:21.785] -----
[2018-05-24 20:48:21.881] Temperature 36.16 C 75.00 C -5.00 C 70.00 C 0.00 C
[2018-05-24 20:48:21.961] Voltage 3.23 V 3.63 V 2.97 V 3.46 V 3.13 V
[2018-05-24 20:48:22.040] Current 41.13 mA 131.00 mA 15.00 mA 130.00 mA 20.00 mA
[2018-05-24 20:48:22.121] Tx Power 0.81 dBm 7.49 dBm -8.32 dBm 4.49 dBm -4.30 dBm
[2018-05-24 20:48:22.201] Rx Power 2.54 dBm 7.49 dBm -14.68 dBm 4.49 dBm -10.60 dBm
[2018-05-24 20:48:22.281] Transmit Fault Count = 0
[2018-05-24 20:48:22.313] -----
[2018-05-24 20:48:22.392] Note: ++ high-alarm; + high-warning; -- low-alarm; - low-warning

```

```

[2018-05-24 20:48:22.473]
[2018-05-24 20:48:22.473] Lane Number:2 Network Lane
[2018-05-24 20:48:22.504] SFP Detail Diagnostics Information (internal calibration)
[2018-05-24 20:48:22.569] -----
[2018-05-24 20:48:22.664] Current Alarms Warnings
[2018-05-24 20:48:22.728] Measurement High Low High Low
[2018-05-24 20:48:22.808] -----
[2018-05-24 20:48:22.889] Temperature 36.16 C 75.00 C -5.00 C 70.00 C 0.00 C
[2018-05-24 20:48:22.968] Voltage 3.23 V 3.63 V 2.97 V 3.46 V 3.13 V
[2018-05-24 20:48:23.064] Current 40.29 mA 131.00 mA 15.00 mA 130.00 mA 20.00 mA
[2018-05-24 20:48:23.147] Tx Power 0.93 dBm 7.49 dBm -8.32 dBm 4.49 dBm -4.30 dBm
[2018-05-24 20:48:23.226] Rx Power 2.54 dBm 7.49 dBm -14.68 dBm 4.49 dBm -10.60 dBm
[2018-05-24 20:48:23.307] Transmit Fault Count = 0
[2018-05-24 20:48:23.337] -----
[2018-05-24 20:48:23.418] Note: ++ high-alarm; + high-warning; -- low-alarm; - low-warning
[2018-05-24 20:48:23.496]
[2018-05-24 20:48:23.496] Lane Number:3 Network Lane
[2018-05-24 20:48:23.528] SFP Detail Diagnostics Information (internal calibration)
[2018-05-24 20:48:23.593] -----
[2018-05-24 20:48:23.673] Current Alarms Warnings
[2018-05-24 20:48:23.754] Measurement High Low High Low
[2018-05-24 20:48:23.831] -----
[2018-05-24 20:48:23.913] Temperature 36.16 C 75.00 C -5.00 C 70.00 C 0.00 C
[2018-05-24 20:48:23.993] Voltage 3.23 V 3.63 V 2.97 V 3.46 V 3.13 V
[2018-05-24 20:48:24.072] Current 40.22 mA 131.00 mA 15.00 mA 130.00 mA 20.00 mA
[2018-05-24 20:48:24.151] Tx Power 1.15 dBm 7.49 dBm -8.32 dBm 4.49 dBm -4.30 dBm
[2018-05-24 20:48:24.247] Rx Power 2.25 dBm 7.49 dBm -14.68 dBm 4.49 dBm -10.60 dBm
[2018-05-24 20:48:24.326] Transmit Fault Count = 0
[2018-05-24 20:48:24.362] -----
[2018-05-24 20:48:24.442] Note: ++ high-alarm; + high-warning; -- low-alarm; - low-warning
[2018-05-24 20:48:24.522]
[2018-05-24 20:48:24.522] Lane Number:4 Network Lane
[2018-05-24 20:48:24.551] SFP Detail Diagnostics Information (internal calibration)
[2018-05-24 20:48:24.616] -----
[2018-05-24 20:48:24.695] Current Alarms Warnings
[2018-05-24 20:48:24.777] Measurement High Low High Low
[2018-05-24 20:48:24.856] -----
[2018-05-24 20:48:24.935] Temperature 36.16 C 75.00 C -5.00 C 70.00 C 0.00 C
[2018-05-24 20:48:25.021] Voltage 3.23 V 3.63 V 2.97 V 3.46 V 3.13 V
[2018-05-24 20:48:25.095] Current 40.22 mA 131.00 mA 15.00 mA 130.00 mA 20.00 mA
[2018-05-24 20:48:25.184] Tx Power 1.52 dBm 7.49 dBm -8.32 dBm 4.49 dBm -4.30 dBm
[2018-05-24 20:48:25.256] Rx Power 2.25 dBm 7.49 dBm -14.68 dBm 4.49 dBm -10.60 dBm
[2018-05-24 20:48:25.354] Transmit Fault Count = 0
[2018-05-24 20:48:25.369] -----2011 -----
---
[2018-05-24 20:48:25.464] Jul 1 03:02:12 switch Note: ++ high-alarm; + high-warning; -- low-alarm; -
low-warning
[2018-05-24 20:48:25.559] %$ VDC-1 %$ last message repeated 1 time
[2018-05-24 20:48:25.609]
[2018-05-24 20:48:25.609] switch# show interface ethernet 1/49 status
[2018-05-24 20:48:30.276]
[2018-05-24 20:48:30.276] -----
[2018-05-24 20:48:30.356] Port Name Status Vlan Duplex Speed Type
[2018-05-24 20:48:30.438] -----
[2018-05-24 20:48:30.516] Eth1/49 -- connected 2 full 100G QSFP-100G-
LR4
[2018-05-24 20:48:30.612] switch#

```

## For More Information

Technical information in this document is subject to change without notice. For more information see the [SFP Line Card](#) or the [SFP/XFP Landing page](#).

## Compliance Information

The fiber optic transmitters on this device meet Class I Laser safety requirements per IEC-825/CDRH standards and comply with 21 CFR1040.10 and 21CFR1040.11.

**WARNING:** Visible and invisible laser radiation when open. Do not stare into the beam or view the beam directly with optical instruments. Failure to observe this warning could result in an eye injury or blindness.

**IMPORTANT:** Copper based media ports such as Twisted Pair (TP) Ethernet, USB, RS232, RS422, RS485, DS1, DS3, Video Coax, etc., are intended to be connected to intra-building (inside plant) link segments that are not subject to lightning transients or power faults. Copper-based media ports such as Twisted Pair (TP) Ethernet, USB, RS232, RS422, RS485, DS1, DS3, Video Coax, etc., are NOT to be connected to inter-building (outside plant) link segments that are subject to lightning transients or power faults.

### Class I Laser Compliance

This product has been tested and found to comply with the limits for FDA Class I laser for IEC60825, EN60825, and 21CFR1040 specifications.

### Translated Safety Warnings

**Warning** Class I laser product.

**Waarschuwing** Klasse-I laser produkt.

**Varoitus** Luokan I lasertuote.

**Attention** Produit laser de classe I

**Warnung** Laserprodukt der Klasse I.

**Avvertenza** Prodotto laser di Classe I.

**Advarsel** Laserprodukt av klasse I.

**Aviso** Produto laser de classe I.

**¡Advertencia!** Producto láser Clase I.

**Varning!** Laserprodukt av klass I.

**Aviso** Produto a laser de classe I.

**Advarsel** Klasse I laserprodukt.

### FCC Regulations

This equipment has been tested and found to comply with the limits for a Class A digital device, pursuant to Part 15 of the FCC rules. These limits are designed to provide reasonable protection against harmful interference when the equipment is operated in a commercial environment. This equipment generates, uses and can radiate radio frequency energy and, if not installed and used in accordance with the instruction manual, may cause harmful interference to radio communications.

Operation of this equipment in a residential area is likely to cause harmful interference, in which case the user will be required to correct the interference at the user's own expense.

### Canadian Regulations

This digital apparatus does not exceed the Class A limits for radio noise for digital apparatus set out on the radio interference regulations of the Canadian Department of Communications.

Le présent appareil numérique n'émet pas de bruits radioélectriques dépassant les limites applicables aux appareils numériques de la Class A prescrites dans le Règlement sur le brouillage radioélectrique édicté par le ministère des Communications du Canada.

## European Regulations

### Warning

This is a Class A product. In a domestic environment this product may cause radio interference in which case the user may be required to take adequate measures.

### Achtung !

Dieses ist ein Gerät der Funkstörgrenzwertklasse A. In Wohnbereichen können bei Betrieb dieses Gerätes Rundfunkstörungen auftreten. In diesem Fall ist der Benutzer für Gegenmaßnahmen verantwortlich.

### Attention !

Ceci est un produit de Classe A. Dans un environnement domestique, ce produit risque de créer des interférences radioélectriques, il appartiendra alors à l'utilisateur de prendre les mesures spécifiques appropriées.



In accordance with European Union Directive 2002/96/EC of the European Parliament and of the Council of 27 January 2003, Lantronix will accept post usage returns of this product for proper disposal. The contact information for this activity can be found in the 'Contact Us' portion of this document.

Der Anschluss dieses Gerätes an ein öffentliches Telekommunikationsnetz in den EGMitgliedstaaten verstösst gegen die jeweiligen einzelstaatlichen Gesetze zur Anwendung der Richtlinie 91/263/EWG zur Angleichung der Rechtsvorschriften der Mitgliedstaaten über Telekommunikationsendeinrichtungen einschliesslich der gegenseitigen Anerkennung ihrer Konformität.



CAUTION: RJ connectors are NOT INTENDED FOR CONNECTION TO THE PUBLIC TELEPHONE NETWORK. Failure to observe this caution could result in damage to the public telephone network.

Der Anschluss dieses Gerätes an ein öffentliches Telekommunikationsnetz in den EGMitgliedstaaten verstösst gegen die jeweiligen einzelstaatlichen Gesetze zur Anwendung der Richtlinie 91/263/EWG zur Angleichung der Rechtsvorschriften der Mitgliedstaaten über Telekommunikationsendeinrichtungen einschliesslich der gegenseitigen Anerkennung ihrer Konformität.

**Lantronix Corporate Headquarters**

7535 Irvine Center Drive  
Suite100  
Irvine, CA 92618, USA  
Toll Free: 800-526-8766  
Phone: 949-453-3990  
Fax: 949-453-3995

**Technical Support**

Online: <http://www.transition.com/support>.

**Sales Offices**

For a current list of our domestic and international sales offices, go to the Lantronix web site at [www.lantronix.com/about/contact](http://www.lantronix.com/about/contact).