

SISPM1040-582-LRT

Managed Hardened PoE++ Switch (8) 10/100/1000Base-T PoE++ Ports + (2)
100/1000Base-X SFP Slot

Install Guide

Part Number 33755
Revision J November 2023

Intellectual Property

© 2022, 2023 Lantronix, Inc. All rights reserved. No part of the contents of this publication may be transmitted or reproduced in any form or by any means without the written permission of Lantronix.

Lantronix is a registered trademark of Lantronix, Inc. in the United States and other countries.

All other trademarks and trade names are the property of their respective holders.

Patented: <https://www.lantronix.com/legal/patents/>; additional patents pending.

Warranty

For details on the Lantronix warranty policy, go to <http://www.lantronix.com/support/warranty>.

Contacts

Lantronix Corporate Headquarters

48 Discovery, Suite 250

Irvine, CA 92618, USA

Toll Free: 800-526-8766

Phone: 949-453-3990

Fax: 949-453-3995

Technical Support

Online: <https://www.lantronix.com/technical-support/>

Sales Offices

For a current list of our domestic and international sales offices, go to www.lantronix.com/about/contact.

Disclaimer

All information contained herein is provided "AS IS." Lantronix undertakes no obligation to update the information in this publication. Lantronix does not make, and specifically disclaims, all warranties of any kind (express, implied or otherwise) regarding title, non-infringement, fitness, quality, accuracy, completeness, usefulness, suitability or performance of the information provided herein. Lantronix shall have no liability whatsoever to any user for any damages, losses and causes of action (whether in contract or in tort or otherwise) in connection with the user's access or usage of any of the information or content contained herein. The information and specifications contained in this document are subject to change without notice.

Revision History

Date	Rev	Description
2/18/21	G	Update Ordering information and Software Features. Update DC input information. FW vB7.20.0039: support unified API and 802.3bt standard. Change "Non-stop PoE" to "Always-On PoE". Add Auto-logout, SFTP copy commands, and RADIUS Server Attribute 6 Service-Type attribute option.
9/28/22	H	Add certifications; initial Lantronix rebrand. Add IEEE 802.3bt Power Input Ripple and Noise Specification. Update contact information. Add ConsoleFlow and LPM support.
11/7/23	J	FW v B7.20.0191: Change ConsoleFlow to PercepXion. Support API in HTTPS. Add LEVEL Technical Support option. Update SSH. Add UL 2108 and delete UL 2043 Cert. Add PS 25104 UK DoC. Add two public OIDs. Update to Dropbear 2022.82. Update Initial Switch Setup procedures.

Safety Cautions and Warnings

Cautions indicate that there is the possibility of poor equipment performance or potential damage to the equipment. **Warnings** indicate that there is the possibility of injury to person.

Cautions and Warnings appear here and may appear throughout this manual where appropriate. Failure to read and understand the information identified by this symbol could result in poor equipment performance, damage to the equipment, or injury to persons.



Caution: While installing or servicing the power supply module, wear a grounding device and observe all electrostatic discharge precautions. Failure to observe this caution could result in damage to, or failure of the power module.



Warning: Do not connect the power module to an external power source before installing it into the chassis. Failure to observe this warning could result in an electrical shock, even death.

Warning: Equipment grounding is vital to ensure safe operation. The installer must ensure that the power module is properly grounded during and after installation. Failure to observe this warning could result in an electric shock, even death.

Warning: A readily accessible, suitable National Electrical Code (NEC) or local electrical code approved disconnect device and branch-circuit protector must be part of the building's installed wiring to accommodate permanently connected equipment. Failure to observe this warning could result in an electric shock, even death.

Warning: Turn any external power source OFF and ensure that the power module is disconnected from the external power source before performing any maintenance. Failure to observe this warning could result in an electrical shock, even death.

Warning: Ensure that the disconnect device for the external power source is OPEN (*turned OFF*) before disconnecting or connecting the power leads to the power module. Failure to observe this warning could result in an electric shock, even death.

See [Electrical Safety Warnings](#) on page 52 for electrical safety warnings translated into multiple languages.

Contents

1	Introduction	6
	Key Features	6
	Benefits	6
	Specifications	8
	Software Features	10
	Application Example	13
	About This Manual	14
	Related Manuals	14
2	Product Description	15
	Overview	15
	Back Panel	15
	Front Panel	16
	LED Indicators	17
	DIP Switch for Ring Settings	19
	RESET Button	20
3	Installation	21
	Package Contents	21
	Mounting the Switch on a DIN Rail	22
	Mounting the Switch on a Wall (Optional)	23
	Grounding Screw	24
	Installing SFP Modules	25
	Connecting Devices	25
	Connecting Powered Devices (PDs)	26
	Connecting the DI/DO (Digital Input / Digital Output) Relay	26
	Connecting P1 and P2 (54 VDC Power Inputs)	28
	Power Supply Specifications	29
	480W Din Rail Power Supply (25160)	29
	Power Supply Views (25160)	30
	Power Supply Dimensions (25160)	31
	Power Supply Pin Descriptions (25160)	32
	240W Din Rail Power Supply (25104)	33
	Power Supply Features (25104)	33
	Power Supply Specifications (25104)	33
	PS-DC-DUAL-5624 Power Supply	34
4	Initial Switch Setup	35
	Initial Switch Setup via Web Browser	35
	Initial Switch Configuration via CLI	36
5	Troubleshooting, Support, and Compliance	37
	Troubleshooting	37
	General Troubleshooting	37
	LED Troubleshooting	38
	PoE Modes and Compliance	39
	PoE History	39
	PoE Standards Comparison	39
	PoE Types	40
	PoE Classes	41
	PoE Deployment Environments A and B	41
	Mode A vs. Mode B	42
	802.3af/at Standard "compliant" vs "compatible" PDs	42
	Typical PD Power Requirements	42

Calculate PoE Power Budget.....	42
Mixing POE and Non-POE Devices	42
Ethernet and PoE Intra-Building Cabling Warnings	43
Legacy PD Detection / Capacitor Detection.....	43
PoE ++ Connectivity, Arcing, and Temperature Issues	43
PoE/PoE+/PoE++ Comparison Chart	44
Notes from Draft Standard for Ethernet Amendment 2: PoE over 4 Pairs (IEEE 802.3bt).....	44
IEEE 802.3bt Power Input Ripple and Noise Specification	44
Term Definitions	45
General Safety	45
Network Safety	46
Patch Panel Considerations.....	46
Electromagnetic Emissions	46
Temperature and Humidity.....	46
Labeling	46
Product Labeling	47
Recording Device and System Information.....	48
Compliance Information	49
FCC Regulations	49
Canadian Regulations	49
Declaration of Conformity (DoC)	49
Class I, Division 2 / classe I, division 2	50
High Risk Activities Disclaimer.....	50
Safety Statements	50
RoHS, WEEE, and Environmental Programs	50
Cautions and Warnings.....	51
Electrical Safety Warnings	52

1 Introduction

The SISPM1040-582-LRT is a managed PoE++ switch suitable for connecting and powering devices in hardened environments. It has (8) 10/100/1000 PoE++ ports with (2) 100/1000 dual speed SFP slots. The switch can supply up to 90 Watts per port on (4) ports or 60 Watts per port on (8) ports simultaneously. The switch also includes the embedded Device Management System (DMS) software that provides the advanced tools necessary for total management of all IP addressable devices. The unique DMS provides security integrators with lower overall cost, less downtime and easier management of the entire PoE+ network. Lantronix hardened switches are certified to operate reliably in harsh environments such as those found on factory floors, outdoor enclosures, or other challenging environments.

Key Features

- IEEE 802.3bt PoE++, 802.3at PoE+, and 802.3af PoE
- PoE Auto Power Reset, Always on PoE, PoE Configuration, Scheduling, and Power Delay
- DMS (Device Management System) Graphical Monitoring, Traffic Monitoring, Troubleshooting
- Perception and LPM (Lantronix Provisioning Manager) support
- Rapid Ring / Ring to Ring / Rapid Chain
- ITU-T G.8031 Ethernet Linear Protection Switching (EPS)
- ITU-T G.8032 Ethernet Ring Protection Switching (ERPS)
- IEEE 1588v2 PTP
- IEEE 802.3ah OAM
- IEEE 802.1ag CFM (ITU-T Y.1731 Performance monitoring)
- DHCP Server, DHCP Relay, DHCP Snooping, DHCP Per Port
- IEEE 802.3az Energy Efficient Ethernet (EEE) for green Ethernet application
- IPv4/IPv6 L3 static route
- IEC 62439-2 MRP (Media Redundancy Protocol)
- IPv4/IPv6 dual protocols
- Supports Jumbo Frame up to 9K bytes
- NDAA Compliant and TAA Compliant

Benefits

- **Feature-rich Specifications to support various applications:** The switch delivers extensive industrial and carrier grade functionalities, including R-Ring, ITU-T G.8031, ITU-T G.8032, IEEE 1588v2 PTP, OAM, CFM, etc. It also has enhanced L2/L3 features for better manageability and usability. The SISPM1040-582-LRT provides advanced PoE features such as PoE auto-checking, PoE scheduling, PoE Auto Power Reset, and PoE power delay to manage PDs more easily.
- **Exceptional Precision with IEEE 1588v2 PTP:** The switch performs IEEE 1588v2 PTP with transparent clock capability, implementations in hardware, so there is no performance penalty on packet processing. The hardware architecture ensures low latency and high time accuracy, critical for delay-sensitive financial and mobile applications.
- **Superior Reliability with OAM and CFM for Service Assurance:** Service assurance is provided with a rich feature set of operations, administration, and maintenance (OAM) functions. It can simplify and facilitate the management of Carrier network, resulting in diminishing operational costs. The Ethernet access device also offers standards-based fault and performance management in adherence with ITU-T Y.1731 PM (Performance Monitoring) and IEEE 802.1ag connectivity fault management (CFM) standards. These

features contribute to significant reduction in operational expenditures and allows for troubleshooting without expensive truck rolls.

- **Easy to Install, Configure and Troubleshoot with DMS:** the embedded Device Management System (DMS) provides embedded functions to facilitate devices management at anytime and anywhere. Its user-friendly interface helps manage devices intuitively. It supports various IP device types (e.g., PC, IP-phones, PTZ cameras, WAPs) to enhance manageability and save time and cost during installation and maintenance.
- **Lower TCO with Energy-efficient design:** The switch is designed to help companies save power and reduce TCO by Energy Efficient Ethernet (IEEE 802.3az). It can help build a green Ethernet network environment.

Ordering Information

SKU	Description
SISPM1040-582-LRT	Hardened PoE++ Switch. (8) 10/100/1000Base-T PoE++ and (2) 100/1000Base-X SFP slots; 52V - 57 VDC.
Optional Accessories (sold separately)	
PercepXion	Centralized Management Software for Lantronix devices. Cloud-based and On premise support. Sold separately.
SFPs	See Lantronix full line of SFP transceivers on our SFP webpage . Sold separately.
25160	Industrial Power Supply . Input 90-264 VAC, 127-370 VDC. Output: 48 ~ 55 VDC, 10A, 480 Watts; sold separately.
25104	Industrial Power Supply . Input: 85-264 VAC, 124-370 VDC. Output: 48 ~ 55 VDC, 5A, 240 Watts; sold separately.
PS-DC-DUAL-5624T	PS-DC-DUAL Power Supply ; Input: 100-240 VAC; 56VDC + 24V output. Sold separately.
WMBH-01	Wall Mount Bracket; sold separately.
DRBH-01	Din Rail Bracket; sold separately.
EDCA-DIO-01	Enclosure Door Contact Alarm (security device option ; sold separately).
OCA-P181610	18x16x10" Polycarbonate Enclosure ; sold separately.
Level 1 Technical Services	Provides Online Help Service, Help Ticket Portal, Phone Support 24/7, 4-Hour Ticket Response, Software Updates, Configuration Assistance, Limited Lifetime Warranty, and Advanced Hardware Replacement. See the Lantronix LEVEL Technical Services webpage . Sold separately.
Level 2 Technical Services	Provides Level 1 Technical Services plus an Assigned Technical Account Specialist. See the Lantronix LEVEL Technical Services webpage . Sold separately.
Level 3 Technical Services	Provides Level 2 Technical Services plus Custom MSA and SLA Contract. See the Lantronix LEVEL Technical Services webpage . Sold separately.

Specifications

Port Configuration

Total Ports	RJ45 (10M/100M/1G)	Uplinks (100M/1G)	Console	Ring Mgmt.	DI/DO
10	8	2 SFP	RJ45	DIP switch	1/1

Hardware Performance

Forwarding Capacity (Mpps)	Switching Capacity (Gbps)	Mac Table (K)	Jumbo Frames (Bytes)
14.88	20	8	9216

Environmental Range

Operating Temperature		Storage Temperature		Operating Humidity	Altitude	
Fahrenheit	Centigrade	Fahrenheit	Centigrade	5% to 95% non-condensing	Feet	Meters
-40° to +167°	-40° to +75°	-40° to +185°	-40° to +85°		<10000	<3000

Dimensions, Weight, Mounting

Dimensions (WxHxD)		Weight		Mounting Type
Millimeters	Inches	Kilograms	Pounds	
62 x 135 x 130	2.4 x 5.3 x 5.1	0.8	1.7	DIN rail; Wall (Optional)

Voltage and Frequency

Primary Power Supply - DC Input Voltage	
DC Nominal	54 VDC dual inputs
DC Operating Range	48 to 57 VDC. IEE 802.3af:48-57VDC; 802.3at: 52-57VDC; 802.3bt: 54-57VDC.
Power Consumption	13W without PoE

PoE Support: The switch can supply up to 90 Watts per port on four ports simultaneously, or 60 Watts per port on eight ports simultaneously.

Available PoE Power	Number of Ports that support PoE (15.4W), PoE+ (30.0W), PoE++ (60W), PoE++ (90W)
480W	Each of ports 1 - 8 support PoE++ within available PoE Power. Max PoE Budget 480 Watts. 60 Watts for (8) ports simultaneously; up to 90 Watts on (4) ports simultaneously.

MTBF

Hours	Environment
296,997	GB, GC - Ground Benign, Controlled 25°C
82,976	GB, GC - Ground Benign, Controlled 75°C

Certifications

Compliance	
EMS	EN61000-4-2 ESD, EN61000-4-3 RS, EN61000-4-4 EFT, EN61000-4-5 (for RJ45 Port, Surge 6KV), EN61000-4-6 CS, EN61000-4-8 PFMF
EMI	FCC Part 15 Class A
Safety	CE, EN62368-1, IEC62368-1 UL 2108, 2nd Edition, Revision Date 2019-12-06
Transportation	NEMA TS2 (traffic signaling equipment)
Ingress Protection	IP30
Mechanical Stability	
Vibration	IEC 60068-2-6
Shock	IEC 60068-2-27
Freefall	IEC 60068-2-32
Compliant	
Substation	IEC 61850-3, IEEE 1613, UL, Class I Div 2
Traffic signaling equipment	NEMA TS 2-2016: 2.2.7 Transients, Temperature and Humidity 2.2.8 Vibration test 2.2.9 Shock test

Software Features

Ring Management	
ITU-T G.8031	Supports ITU-T G.8031 Ethernet Linear Protection Switching (EPS)
ITU-T G.8032	Supports ITU-T G.8032 Ethernet Ring Protection Switching (ERPS)
Rapid Ring	Enables self-recovery time in less than 20ms; configurable via DIP switch, CLI or Web UI: Single Ring, Ring to Ring, Dual Ring, and Rapid Chain
MRP (Media Redundancy Protocol)	The MRP data network protocol, standardized by IEC 62439-2, allows rings of Ethernet switches to overcome a single failure with recovery time much faster than with Spanning Tree Protocol
Device Management System (DMS)	
Graphical Monitoring	<ul style="list-style-type: none"> • Topology view: Intuitive way to configure and manage switches and devices visually • Floor view: Easily drag and drop PoE devices to help you build a smart workforce • Map view: Effectively drag and drop devices and monitor operation on Google Maps
Find my Switch	Search for and locate a specific switch quickly
Traffic Monitoring	Display visual chart of network traffic of all devices and monitor every port at any time from switches
Troubleshooting	<ul style="list-style-type: none"> • Network diagnostic between master switch and devices • Support protection mechanism, such as rate-limiting to protect your devices from brute-force downloading • Support performance management and link management through IEEE 802.3ah and IEEE 802.1ag (Y.1731)
Google Map API Key	<ul style="list-style-type: none"> • Set up Google Maps API Key to use DMS Map View for enterprise applications
Ethernet OAM	
IEEE 802.3ah OAM	Supports Operations, Administration & Management
IEEE 802.1ag & ITU-T Y.1731 Flow OAM	<ul style="list-style-type: none"> • Supports IEEE 802.1ag Ethernet CFM (Connectivity Fault Management) • Supports ITU-T Y.1731 Performance Monitoring
Layer 2 Switching	
Spanning Tree Protocol (STP)	<ul style="list-style-type: none"> • Standard Spanning Tree 802.1d • Rapid Spanning Tree (RSTP) 802.1w • Multiple Spanning Tree (MSTP) 802.1s
Trunking	<ul style="list-style-type: none"> • Link Aggregation Control Protocol (LACP) IEEE 802.3ad • Up to 6 groups and up to 4 ports per group
VLAN	<ul style="list-style-type: none"> • Port-based VLAN • 802.1Q tag-based VLAN • MAC-based VLAN • Management VLAN • Private VLAN Edge (PVE) • Q-in-Q (double tag) VLAN • Voice VLAN • GARP VLAN Registration Protocol (GVRP)
DHCP Relay	<ul style="list-style-type: none"> • Relay of DHCP traffic to DHCP server in different VLAN. • Works with DHCP Option 82

IGMP v1/v2/v3 Snooping	IGMP limits bandwidth-intensive multicast traffic to only the requesters. Supports 1024 multicast groups
IGMP Querier	IGMP querier is used to support a Layer 2 multicast domain of snooping switches in the absence of a multicast router
IGMP Proxy	IGMP snooping with proxy reporting or report suppression actively filters IGMP packets in order to reduce load on the multicast router
MLD v1/v2 Snooping	Delivers IPv6 multicast packets only to the required receivers
Multicast VLAN Registration (MVR)	It uses a dedicated manually configured VLAN, called the multicast VLAN, to forward multicast traffic over Layer 2 network in conjunction with IGMP snooping.
Layer 3 Switching	
IPv4 Static Routing	IPv4 Unicast: Static routing
IPv6 Static Routing	IPv6 Unicast: Static routing
Security	
Secure Shell (SSH)	SSH secures Telnet traffic in or out of the switch; SSH v1 and v2 are supported
Secure Sockets Layer (SSL)	SSL encrypts the http traffic, allowing advanced secure access to the browser-based management GUI in the switch
IEEE 802.1X	<ul style="list-style-type: none"> • IEEE802.1X: RADIUS authentication, authorization and accounting, MD5 hash, guest VLAN, single/multiple host mode and single/multiple sessions • Supports IGMP-RADIUS based 802.1X • Dynamic VLAN assignment
Layer 2 Isolation Private VLAN Edge	PVE (aka protected ports) provides L2 isolation between clients in the same VLAN. Supports multiple uplinks.
Port Security	Locks MAC addresses to ports and limits the number of learned MAC address
IP Source Guard	Prevents illegal IP address from accessing to specific port in the switch
RADIUS/ TACACS+	Supports RADIUS and TACACS+ authentication. Switch as a client
Storm Control	Prevents traffic on a LAN from being disrupted by a broadcast, multicast, or unicast storm on a port
DHCP Snooping	Feature acts as a firewall between untrusted hosts and trusted DHCP servers
ACLs	Supports up to 256 entries. Drop or rate limitation based on: <ul style="list-style-type: none"> • Source and destination MAC, VLAN ID or IP address, protocol, port, • Differentiated services code point (DSCP) / IP precedence • TCP/ UDP source and destination ports • 802.1p priority • Ethernet type • Internet Control Message Protocol (ICMP) packets • TCP flag
Loop Protection	To prevent unknown unicast, broadcast, and multicast loops in Layer 2 switching configurations
Quality of Service	
Hardware Queues	Supports 8 hardware queues
Scheduling	<ul style="list-style-type: none"> • Strict priority and weighted round-robin (WRR) • Queue assignment based on DSCP and class of service
Classification	<ul style="list-style-type: none"> • Port based • 802.1p VLAN priority based

	<ul style="list-style-type: none"> • IPv4/IPv6 precedence / DSCP based • Differentiated Services (DiffServ) • Classification and re-marking ACLs
Rate Limiting	<ul style="list-style-type: none"> • Ingress policer • Egress shaping and rate control • Per port
Management	
HW Monitoring	Temperature Detection and Alarm
HW Watchdog	Supported to resume operation after CPU hang up.
IEEE 1588v2 PTP	Support IEEE 1588 v2 PTP (Precision Time Protocol)
DHCP Server	Support DHCP server to assign IP to DHCP clients
Remote Monitoring (RMON)	Embedded RMON agent supports RMON groups 1,2,3,9 (history, statistics, alarms, and events) for enhanced traffic management, monitoring and analysis
Port Mirroring	Traffic on a port can be mirrored to another port for analysis with a network analyzer or RMON probe. Up to N-1 (N is Switch's Ports) ports can be mirrored to a single destination port. A single session is supported.
UPnP	The Universal Plug and Play Forum was formed to standardize discovery and control of networked devices. See the Open Connectivity Foundation webpage .
s-Flow	The industry standard for monitoring high speed switched networks. It gives complete visibility into the use of networks enabling performance optimization, accounting/billing for usage, and defense against security threats
IEEE 802.1ab (LLDP)	<ul style="list-style-type: none"> • Used by network devices for advertising their identities, capabilities, and neighbors on an IEEE 802ab local area network • Support LLDP-MED extensions
Web GUI Interface	Built-in switch configuration utility for browser-based device configuration
CLI	To configure/manage switches in command line modes
Dual Image	Independent primary and secondary images for backup while upgrading
SNMP	SNMP version1, 2c and 3 with support for traps, and SNMP version 3 user-based security model (USM)
Firmware Upgrade	<ul style="list-style-type: none"> • Web browser upgrade via HTTP/ HTTPS and TFTP • Upgrade via Console port / CLI
NTP	Network Time Protocol (NTP) for clock synchronization between computer systems over packet-switched
Other Management	<ul style="list-style-type: none"> • HTTP/HTTPS; SSH • DHCP Client/ DHCPv6 Client • Cable Diagnostics • Ping • Syslog • IPv6 Management

Power over Ethernet (PoE)	
Port Configuration	Supports per port PoE configuration function
PoE Scheduling	Supports per port PoE scheduling to turn on/off the PoE devices (PDs)
Auto Power Reset (Auto-checking)	Checks the link status of PDs and reboot PDs if there are no responses
Power Delay	The switch provides power to the PDs based on a delay time when PoE switch boots up, to protect switch from misuse of the PDs. When rebooting, the PoE port will start to provide power to the PD after a configurable delay time.

Perception and LPM	
Perception	<ul style="list-style-type: none"> • Auto-discovery of devices connected to the switch interfaces • Perform on-demand backup and restore of device configuration • Perform secure remote device firmware upgrades • Lantronix-hosted public cloud and On-premise support
LPM	Lantronix Provisioning Manager allows easy administration of Lantronix devices. LPM lets you quickly update firmware, update configuration, and provision one or more devices simultaneously.

Application Example

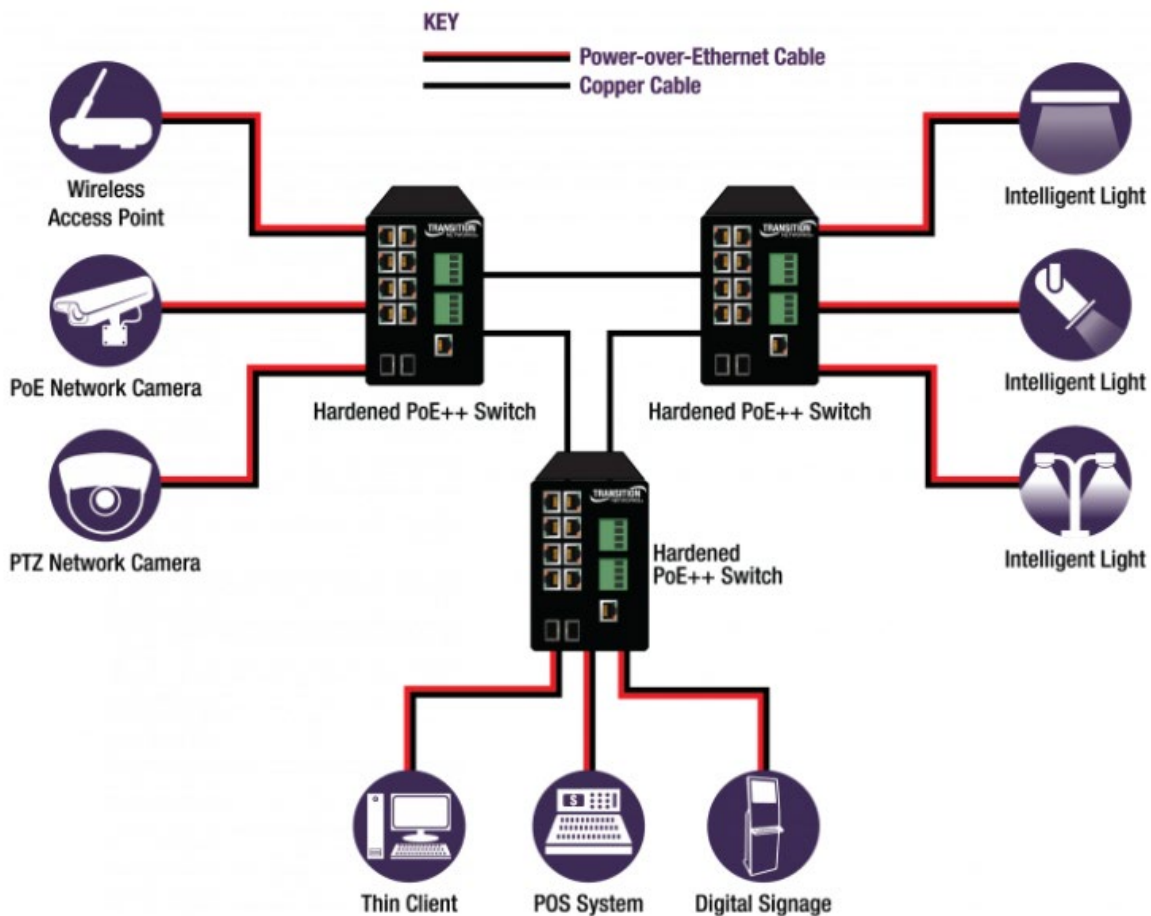

About This Manual

This manual describes how to install, initially configure, and troubleshoot the SISPM1040-582-LRT Switch, including:

- Install the switch,
- check the switch LED status,
- reset the switch or restore the switch to factory defaults, and
- troubleshoot the switch.

Related Manuals

- SISPM1040-582-LRT Quick Start Guide, 33754
- SISPM1040-582-LRT Install Guide, 33755 (this manual)
- SISPM1040-582-LRT Web User Guide, 33756
- SISPM1040-582-LRT CLI Reference, 33757
- SISGM1040-284-LRT API User Guide, 33827
- Release Notes (version specific)

For Lantronix Documentation, Firmware, App Notes, etc. go to <https://www.lantronix.com/technical-support/>. Note that this manual provides links to third party web sites for which Lantronix is not responsible.

2 Product Description

Overview

This section describes the SISPM1040-582-LRT switch, including descriptions of:

- Front and Back Panels
- LEDs
- RESET button
- DIP Switch
- Grounding Screw
- D1 Digital Input / Digital Output (relay)
- P1 and P2 (DC Power Inputs)

Back Panel

The SISPM1040-582-LRT back panel provides for mounting the switch on a wall or in a 19-inch rack.

See [Mounting the Switch on a DIN Rail](#) on page 22 or [Mounting the Switch on a Wall \(Optional\)](#) on page 23.



Front Panel

The SISPM1040-582-LRT front panel ports, LEDs, Power Input terminal block, DI/DO terminal block, CONSOLE port, DIP Switch, RESET button, and Ground screw are shown and described below.

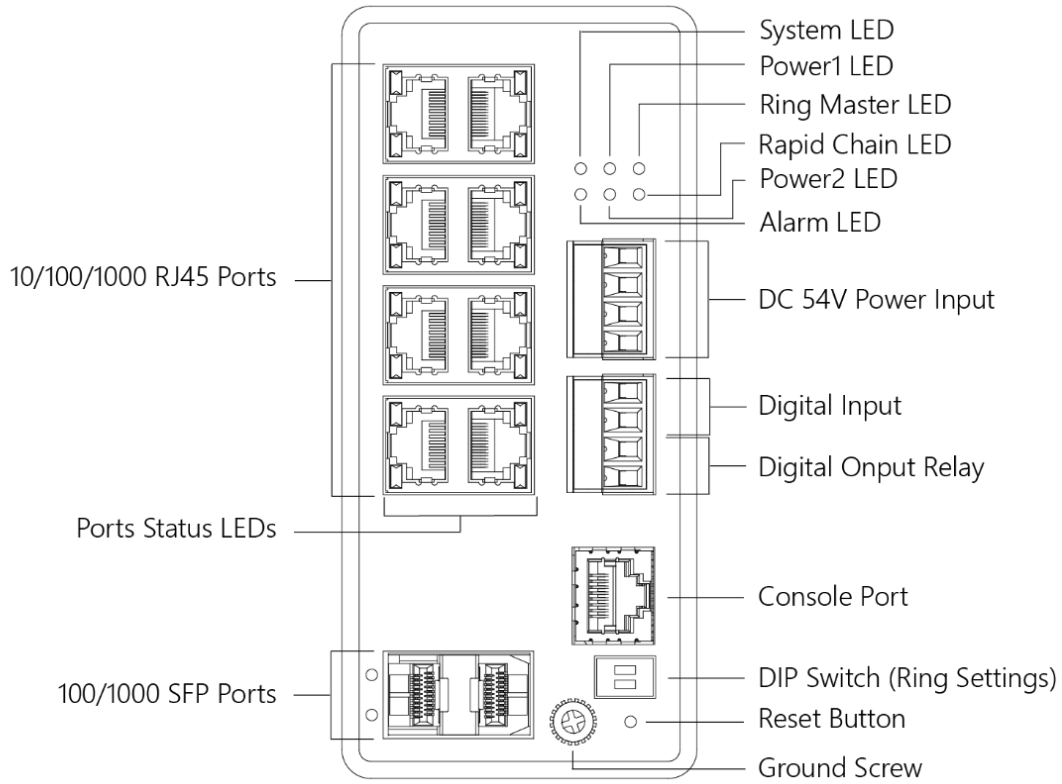

LED Indicators

The front panel LEDs provide for switch status monitoring. The types of LEDs include:

Power LEDs: indicate if the switch is powered up correctly or not.

System LED: indicates if the system is ready or not ready.

Alarm LED: indicates if the system is normal or not.

Ring Master LED and Rapid Chain LED: indicate if the Rapid Ring is ready or not ready.

Port Status LEDs: indicates the current status of each port. Users can check these LEDs to understand the port status.



The following tables detail the various LED functions.

Table 1: Power LEDs

LED	Color	State	Description
P1 (Power 1)	Green	On	The switch is powered ON correctly.
		Off	The switch is not receiving power from power 1.
P2 (Power 2)	Green	On	The switch is powered ON correctly.
		Off	The switch is not receiving power from power 2.

Table 2: System LED

LED	Color	State	Description
SYS (System)	Green	On	The switch is ready.
		Off	The switch is not ready.

Table 3: Alarm LED

LED	Color	State	Description
ALM (Alarm)	Red	On	An abnormal state, such as temperature, voltage or DC power1/2, has been detected in the switch.
		Off	The system state is normal.

You can check the port status by reading the LED behaviors per the table below.

Table 4: Port Status LEDs

LED	Color	State	Description
RJ45 Ports UP	Green	On	The port is enabled and established a link to connected device, and the connection speed is 1000Mbps.
	Green	Blinking	The port is transmitting/receiving packets, and the connection speed is 1000Mbps.
	Amber	On	The port is enabled and established a link to connected device, and the connection speed is 10/100Mbps.
	Amber	Blinking	The port is transmitting/receiving packets, and the connection speed is 10/100Mbps.
	--	Off	The port has no active network cable connected, or it is not established a link to connected device. Otherwise, the port may have been disabled through the switch user interface.
RJ45 Ports Down	Green	On	The port is enabled and supplying power to connected device.
	Amber	On	An abnormal state, such as overload status, has been detected in the switch.
	--	Off	The port has no active network cable connected, or it is not connected a PoE PD device. Otherwise, the port may have been disabled through the switch user interface.
SFP Ports	Green	On	The port is enabled and has established a link to the connected device, and the connection speed is 1000Mbps.
	Green	Blinking	The port is transmitting/receiving packets, and the connection speed is 1000Mbps.
	Amber	On	The port is enabled and established a link to connected device, and the connection speed is 100Mbps.
	Amber	Blinking	The port is transmitting/receiving packets, and the connection speed is 100Mbps.
	--	Off	The port has no active network cable connected, or it is not established a link to connected device. Otherwise, the port may have been disabled through the switch user interface.

Table 5: Ring Master and Rapid Chain LEDs

LED	Color	State	Description
RM (Ring Master)	Green	On	Ring Master has been detected in the switch.
	Amber	On	Ring Member has been detected in the switch.
	--	Off	Disable
RC (Rapid Chain)	Green	On	Rapid Chain has been detected in the switch (Active path).
	Amber	On	Rapid Chain has been detected in the switch (Backup path).
		Blinking	Error: There is no corresponding Rapid Chain switch found.
	--	Off	Disable

DIP Switch for Ring Settings

ERPS (Ethernet Ring Protection Switching) is defined in ITU/T G.8032. It provides fast protection and recovery switching for Ethernet traffic in a ring topology while also ensuring that the Ethernet layer remains loop-free.

The two-position DIP switch is labeled **RC** (1) (Rapid Chain) and **RM** (2) (Ring Master).

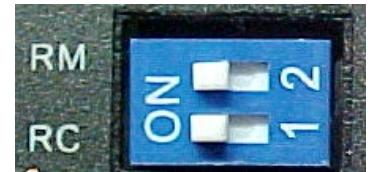

The DIP switch lets you manually set ring settings and not have to access the Web UI or the CLI to configure a ring. The table below shows DIP switch settings for Ring Master and Rapid Chain setup via the DIP switch.

Table 5: Ring Master and Rapid Chain Configuration

RM	RC	Rapid Ring Setting	Ring Port 1	Ring Port 2	RM (Ring Master) LED	RC (Rapid- Chain) LED
Off	Off	Rapid Ring Slave	The maximum odd Port number	The maximum even Port number	Lit Amber	Off
ON	Off	Rapid Ring Master	The maximum odd Port number	The maximum even Port number	Lit Green	Off
Off	ON	Rapid-Chain	The maximum odd Port number	The maximum even Port number	Off	Lit Green (Active Path) Lit Amber (Backup Path)
ON	ON	Rapid Ring settings by Software	--	--	--	--

RESET Button

By pressing the **RESET** button for certain period, you can perform the following tasks.

Reset the Switch to reboot and get the switch back to the previously saved configuration settings.

Restore the Switch to Factory Defaults: to restore the original factory default settings back to the switch.



Note: Use the table below to determine which task is being performed by reading LED status while pressing the **RESET** button. Once the LED behaviors are correctly displayed, just release the **RESET** button.

Table 6: RESET Button Operation

Task	Press RESET button for	SYS LED Behavior	Port Status LED Behavior
Reset the Switch	2 ~ 7 seconds	Blinking Green	ALL LEDs are OFF
Restore to Defaults	7 ~ 12 seconds	Blinking Green	ALL LEDs stay ON

3 Installation

Package Contents

Carefully unpack the package contents in their final location. Verify that you have received the items below.

- One Switch with Terminal Block attached
- One DB-9 to RJ-45 Cable
- Four adhesive rubber feet
- One Printed Quick Start Guide
- One DIN Rail mounting kit



Contact your sales representative if any parts are missing or damaged. Please save the packaging for possible future use.

Caution: The switch is an indoor device. If it is to be used with outdoor devices such as outdoor IP cameras or outdoor Wi-Fi APs, then you are strongly suggested to install a surge protector or surge suppressor to protect the switch.

Compliant with 802.3at in Environment A when using an isolated power supply. For 802.3at Environment B applications, i.e., building to building, copper to copper endpoint connections: 1) use an Ethernet network isolator module (PoE disabled), or 2) use mid-span injector(s) between this switch’s PSE port and link partner PD port.

Warning: Safety First: Turn the power off before connecting or disconnecting modules or wires. The correct power supply voltage is listed on the product label. Check the voltage of your power source to make sure that you are using the correct voltage. Do NOT use a voltage greater than what is specified on the product label.



WARNING
HOT SURFACE
DO NOT TOUCH

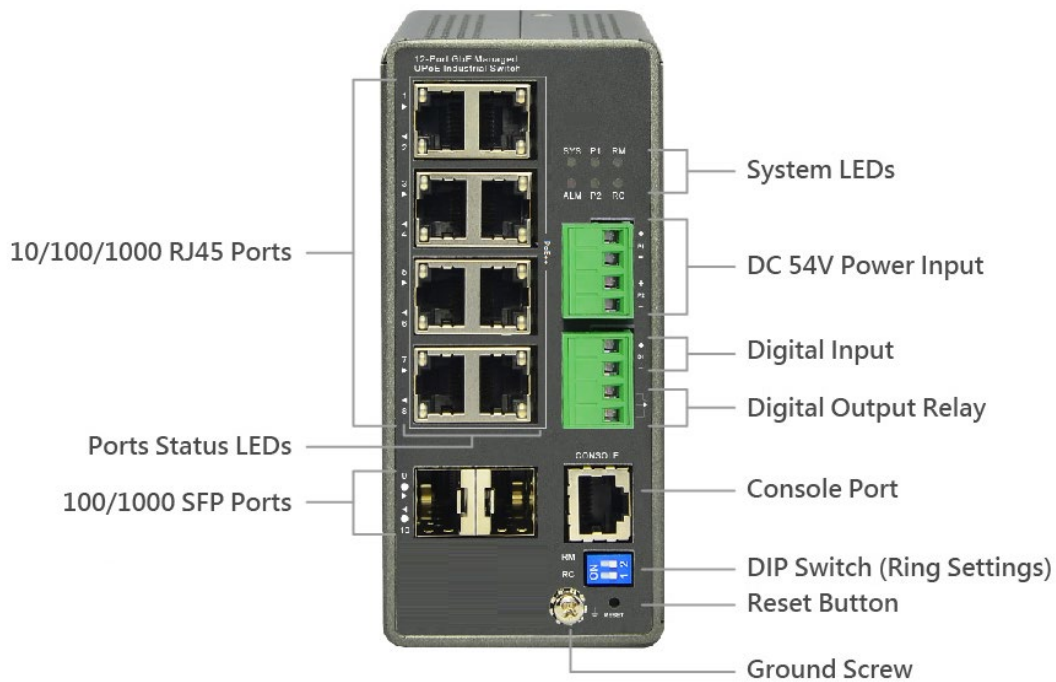

Mounting the Switch on a DIN Rail

1. Attach the DIN Rail mounting kit to the rear panel of the chassis. Insert screws and tighten them with a screwdriver to secure the kit.

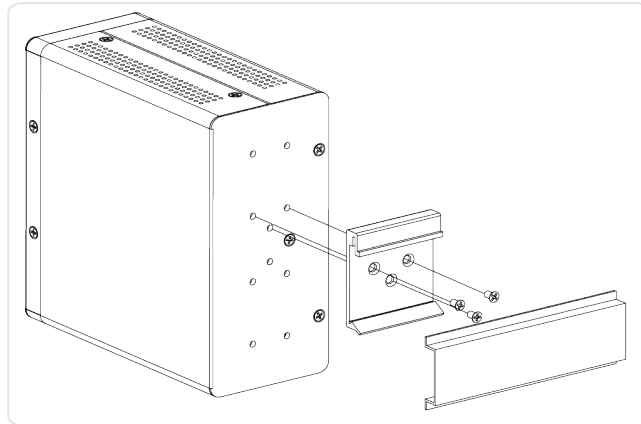

2. Insert the upper lip of the DIN rail into the DIN-rail mounting kit and press the switch towards the DIN rail until it snaps into place.

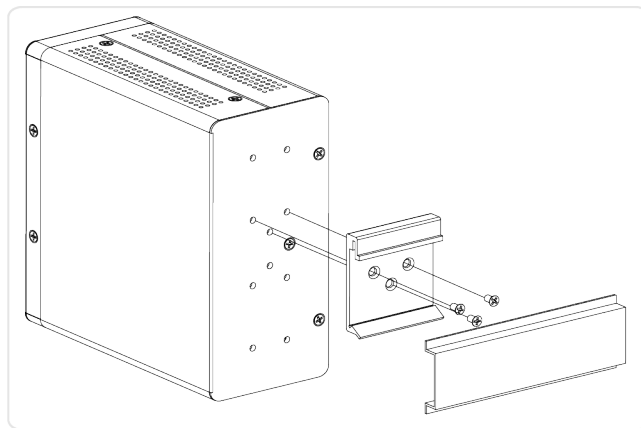

3. Make sure that the switch is attached securely to DIN Rail.

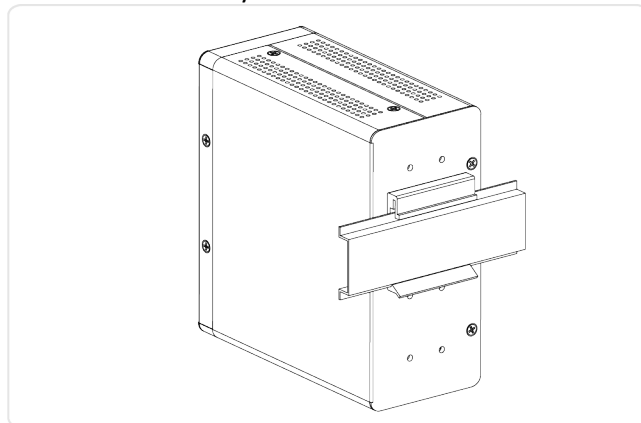

Mounting the Switch on a Wall (Optional)

1. Attach the wall mounting plates to rear panel of the chassis. Insert screws and tighten them with a screwdriver to secure the plates.

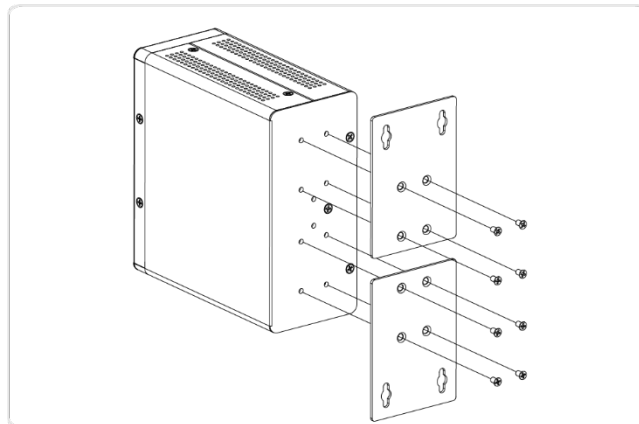

2. Install user-supplied screws on the appropriate location on the wall.

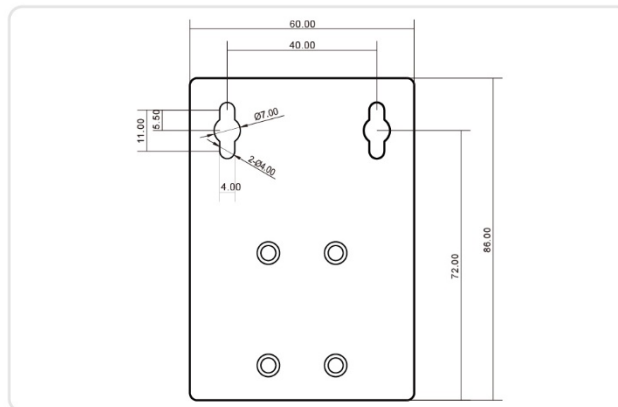

3. Make sure that the switch is attached securely to the wall.

Grounding Screw

ATTENTION: This case must be earth grounded. No DC input may be earth grounded. Use Isolated Power Supply.

Grounding the Switch helps limit the effects of noise due to electromagnetic interference (EMI) via proper grounding. Always run the ground connection from the ground screw to a grounding surface before connecting the Switch to a power source.

Wiring considerations: consider the following wiring recommendations:

- Signal lines must not be directly connected to outdoor wiring.
- Use separate paths or conduits to route wiring for power and device data cables. To avoid interference, wires with different signal characteristics route separately. If power wiring and device data cables must cross, make sure that the wires are perpendicular at the intersection point.
- Use the type of signal transmitted through a wire to determine which wires should be kept separate. The rule of thumb is wiring that shares similar electrical characteristics can be bundled together.
- Keep input and output wiring separated.

CAUTION: The Switch is intended to be grounded to a well-grounded mounting surface such as a metal plate. Install the grounding wire prior to connecting any other device to the Switch.

CAUTION: Be sure to disconnect the Switch from the power source before installing and wiring the device.



Installing SFP Modules

You can install or remove a mini-GBIC SFP module from an SFP port without having to power off the switch.

Note: The SFP ports should use UL Listed Optional Transceiver product, Rated 3.3Vdc, Laser Class 1.

See the SFP manual for important information.

See the [Fiber Optic Association](#) for fiber optics standards and certification.

1. Note the proper orientation and insert the module into the SFP port.
2. Press firmly to ensure that the module seats into the connector.

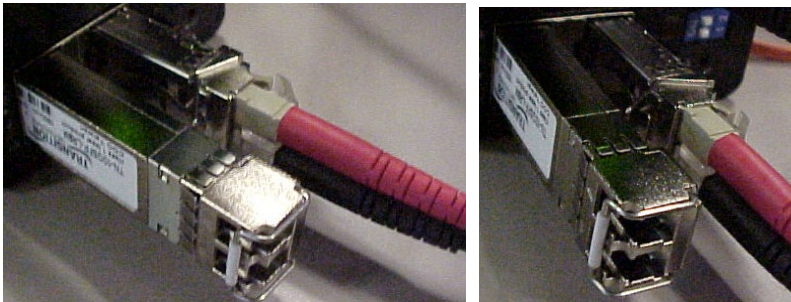
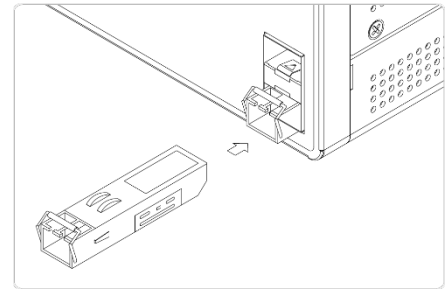

Connecting Devices



All



CONSOLE



RJ-45

Connecting Powered Devices (PDs)

Note that this device does not comply with IEEE 802.3at at 48-51.4 VDC, or with IEEE 802.3bt at 48-53.4 VDC. The old device label states 48-57 VDC. The latest device label indicates:

- 802.3af: 48-57VDC
- 802.3at: 52-57VDC
- 802.3bt: 54-57VDC

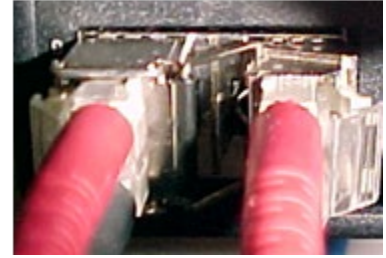

This device drops ~1.3V from V_{in} to PSEout. IEEE requires PSEout voltages at the PSE output into the cable:

- 802.3af: 44VDC
- 802.3at: 50VDC
- 802.3bt: 52VDC

Not meeting this PSEout requirement may cause power up failures or power cycling with devices drawing the maximum power with maximum cable loss.

Connecting the DI/DO (Digital Input / Digital Output) Relay

1. Insert the negative (ground)/positive DI/DO Relay wires into the + and - terminals, respectively.
2. To keep the DI/DO Relay wires from pulling loose, use a small flat-blade screwdriver to tighten the wire-clamp screws on the front of the Terminal Block connector.
3. Insert the Terminal Block connector prongs into the Terminal Block receptor.

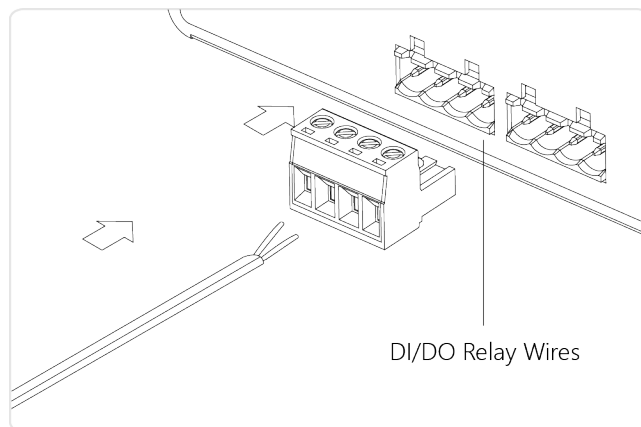

Note:

Digital output (relay): 24VDC/1A

Digital input: level 0 (Low) -> 0V to 6V, level 1 (High) -> 10V to 24V

FAULT: The two contacts of the terminal block connector are used to detect user-configured events. The two wires attached to the fault contacts form an open circuit when a user-configured event is triggered. If a user-configured event does not occur, the fault circuit remains closed.

Digital Input and Digital Output Use Case

The switch supports Digital Input and Digital Output. The Digital Input enables the switch to detect and log external device status (such as door intrusion detector). The Digital Output could be used to tell administrators if the switch port shows link down, link up or power failure. **Note:**

Digital Output (relay): 24VDC/1A

Digital Input:

- Level 0 (Low): 0V to 6V
- Level 1 (High): 10V to 24V

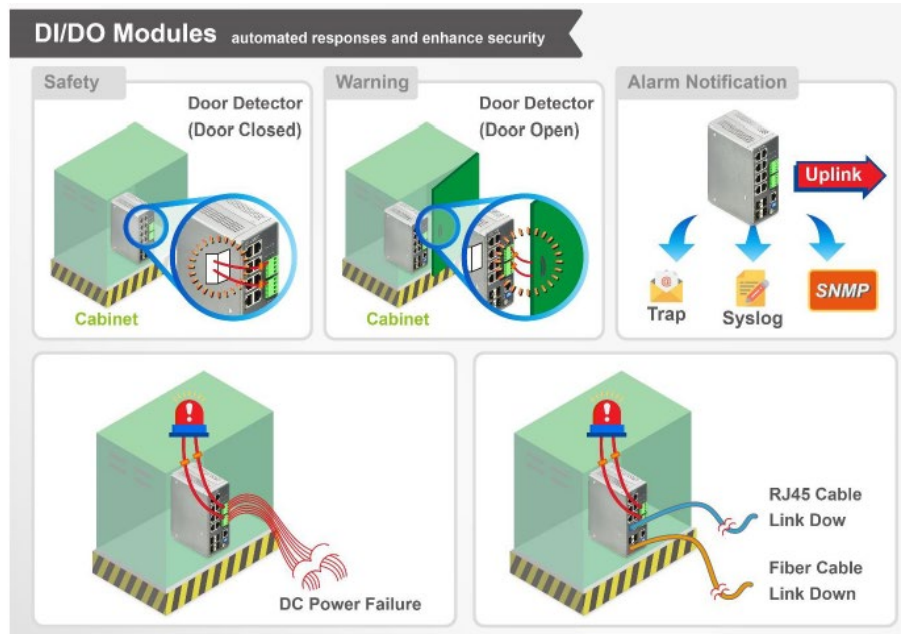

DI: Use for receiving external signal and trigger DO. You may set the voltage input as high or low as DI normal, when DI stays in normal (assume it's set as low), then DO will not response. But the voltage input change to high, DI will show high/ abnormal and at the same time, DO will automatically switch to "abnormal" and send a signal to connected devices, switch will have system recorded.

For example, a water level application:

Setting: low water level: DI normal. High water level: DI abnormal, DIO connected to external alarm notification.

DI will show "normal" when the water level is low. DI will not send signal to DO.

DI will show "abnormal" when sensor senses high water level and will send signal to DO at the same time. DO will turn to abnormal and send signal to external alarm notification to trigger the alarm LED.

DI is used for connecting external alarm devices and once it is triggered the switch can send the trap. An external alarm device (for example: power supply, IP camera) can activate this input pin.

Level 0 (Low): 0V to 6V

Level 1 (High): 10V to 24V

For DO, it's similar but the switch is the alarm device; when the switch has temperature or voltage alarm, it will trigger the digital output (24V/1A) to the external device such as a contact relay.

Connecting P1 and P2 (54 VDC Power Inputs)

Power Connection Warning: Connect the power supply to the switch first, and then connect the power supply to power. Otherwise catastrophic product failure may occur.

1. Verify that power is off to the DC circuit that you are going to attach to the switch PoE DC-input connector. This can be either of the two power supplies (AC-input or DC-input) or site source DC.
2. As an added precaution, place an appropriate safety flag and lockout device at the source power circuit breaker, or place a piece of adhesive tape over the circuit breaker handle to prevent accidental power restoration while you are working on the circuit.

PoE++ Note: The Meanwell 25160 (and other) power supplies may be shipped set to 48VDC. If you unbox the PS, plug it into the SISPM1040-582-LRT and then connect 60W cameras to the switch, the cameras will not power up by POE. The SISPM1040-582-LRT needs 52-57VDC to power all 8 ports. You must use a small Phillips screwdriver to turn up the PS potentiometer to get the VDC up to 52-57VDC. **Note:** Meanwell 25160 power supplies shipped after Sept. 2019 have the default setting changed from 48vdc to 54vdc to provide for additional power required in POE++ environments.

1. Insert the negative/positive DC wires into the **V-** and **V+** terminals, respectively.
2. To keep the DC wires from pulling loose, use a small flat-blade screwdriver to tighten the wire-clamp screws on the front of the Terminal Block connector.
3. Insert the Terminal Block connector prongs into the terminal block receptor.
4. Check the **SYS** LED. If it is ON, the power connection is correct.

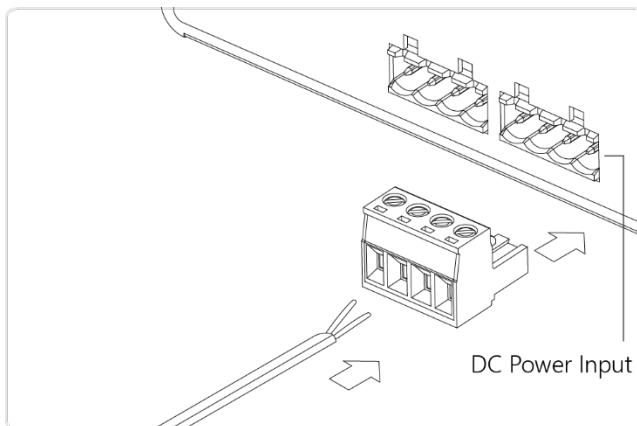

Power Disconnection: To disconnect power from the switch after a successful boot:

1. Turn off power to the switch.
2. Disconnect the cables.

Power Supply Specifications

Note that Power Supplies are sold and packaged separately.

480W Din Rail Power Supply (25160)

Part number: 25160; see the [25160 webpage](#) for product details.

Rated Power: 480W

Input 90 – 264VAC or 127 – 370VDC

Output 48 – 55V

Operating temp. – 25 - +70°C

Description : AC-DC Industrial DIN rail power supply;

Output 48Vdc at 10A; Metal casing; Ultra slim width 85.5mm

Net weight (grams) : 1820

Format : DIN rail

Application : Installation UL 508; ITE EN/UL/IEC 60950

Output Power (W) : 480

Output Voltage (V) : 48

Output Current (A) : 10

Input Voltage (V) : 90-264V; Universal Input 110/230V

IP Rating : No IP

Format : DIN rail

Control Signals : DC OK

Dimming Technology : No Dimming

DC OK Relay Contact

Contact Closed : PSU turns on / DC OK.

Contact Open : PSU turns off / DC Fail.

Contact Ratings (max.) 30V/1A resistive load.

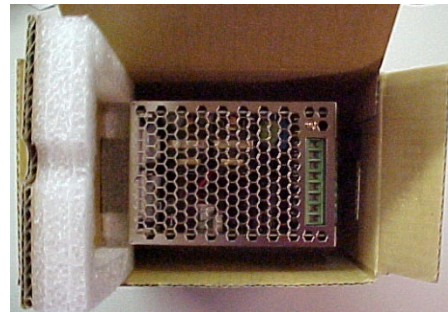

Power Supply Views (25160)



Front:



Back:

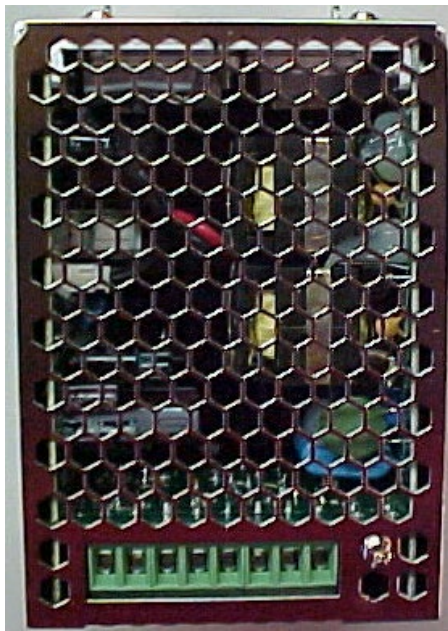

Top:



Bottom:

Power Supply Dimensions (25160)

Width : 85.5 mm (3.36 in.)
Height : 125.2 mm (4.92 in.)
Depth : 128.5 mm (5.05 in.)

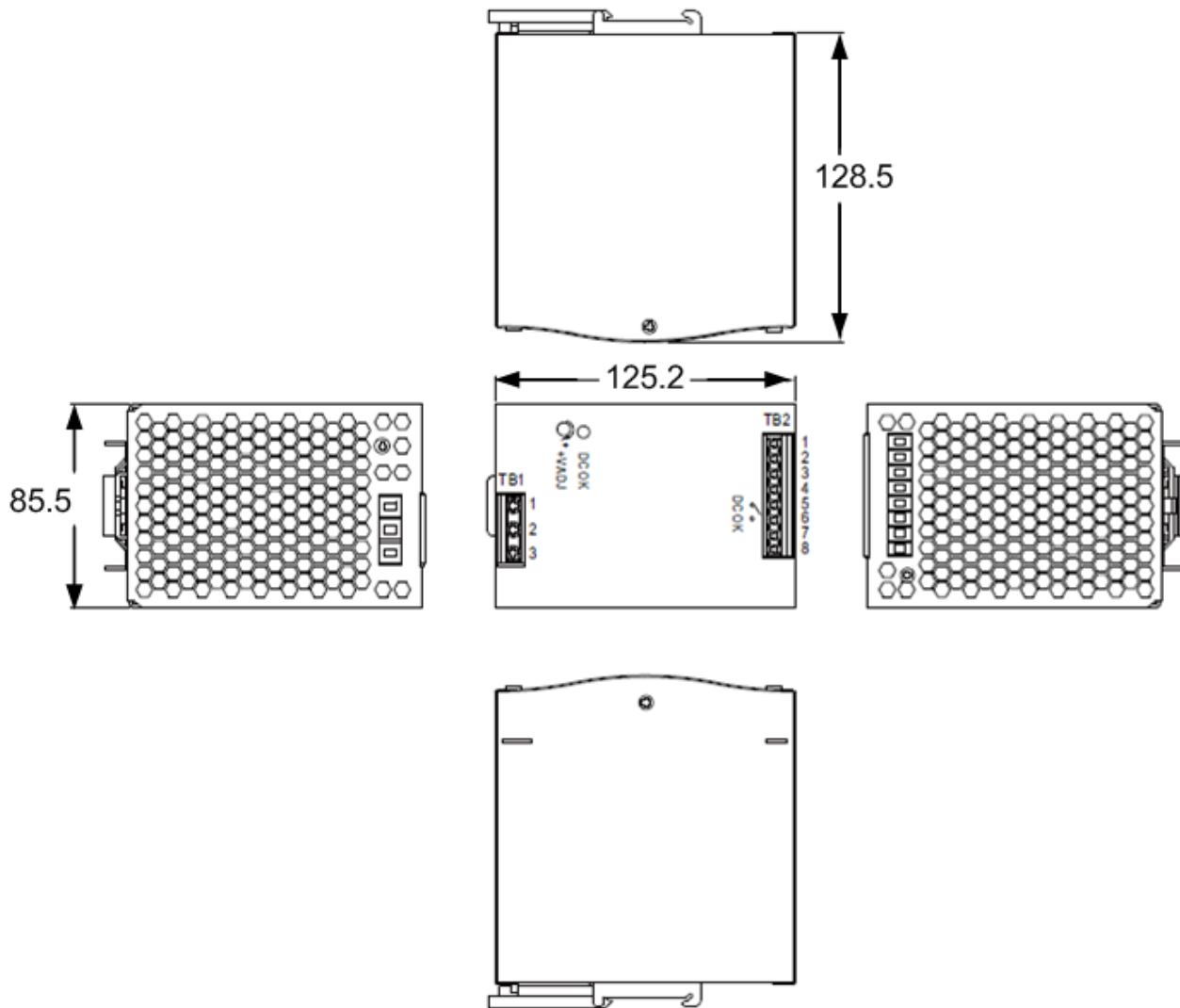

ADMISSIBLE DIN-RAIL: TS35/7.5 OR TS35/15

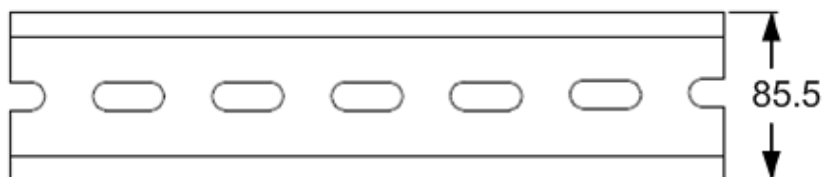

Power Supply Pin Descriptions (25160)

Terminal Pin No. Assignment (TB1)

Pin No.	Assignment
1	FG 
2	AC/N
3	AC/L

Terminal Pin No. Assignment (TB2)

Pin No.	Assignment
1,2	DC OUTPUT +V
3,4	DC OUTPUT -V
5,6	Relay Contact
7,8	NC

DC OK Relay Contact

Contact Close	PSU turns on / DC OK.
Contact Open	PSU turns off / DC Fail.
Contact Ratings (max.)	30V/1A resistive load.

240W Din Rail Power Supply (25104)

Part number: 25104. See the [25104 webpage](#) for product details.

Input: 85-264 VAC, 124-370 VDC

Output: 48 ~ 55 VDC, 5A, 240 Watts

Power Supply Features (25104)

94% High Efficiency

150% Peak Load

Protected against: Short Circuit, Overload, Over Voltage, and Overheating.

Convection air cooling

DIN rail mountable

UL 508 approved

Full load burn in test

RoHS compliant

MTBF 169.3 Khrs

Power Supply Specifications (25104)

Power Output:

Output Voltage 48VDC

Current Rating 5A

Power Rating 240 Watts

Ripple & Noise Max 120mVp-p

Voltage Range 48~55VDC

Voltage Tolerance $\pm 1.0\%$

Line Regulation $\pm 0.5\%$

Load Regulation $\pm 1.0\%$

Setup, Rise Time 300ms, 60ms

Hold Up Time 20ms

Protection:

Overload 105~160%

Overvoltage 56~65V

Dimensions:

Width: 2.48" [63 mm]

Depth: 5.26" [113.5 mm]

Height: 4.93" [125.2 mm]

Environment:

Operating Temp: -25°C to +60°C

Storage Temp: -40°C to +85°C

Humidity: 20% to 95% (non-condensing)

Power Input:

Voltage Range Switch Selectable

88~132VAC

124~370VDC

Frequency Range 47~63Hz

Efficiency 94%

AC Current (Typical) 2.6A@115VAC

1.3A@230VAC

Inrush Current (Cold) 33A@115VAC

65A@230VAC

Weight:

2.27 lbs. [1.03 kg]

Compliance:

Safety: UL508, TUV EN60950-1, IEC60068-2-6

(Vibration) EMC Emission: EN55022, CISPR22 Class

B, EN61000-3-2, EN61000-3-3; EMC Immunity:

EN61000-4-2, EN61000-4-3, EN61000-4-4, EN61000-

4-5, EN61000-4-6, EN61000-4-8, EN61000-4-11,

EN55024, EN61000-6-2, EN50082-2, EN61204-3,

SEMI F47, GL Approved, UKCA

Warranty

Lifetime



PS-DC-DUAL-5624 Power Supply

Stand-alone power supply designed to offer dual DC power output in extended temperature environments. It has a compact form factor and can be DIN rail mounted.

Ordering Information

[PS-DC-DUAL-5624T](#): 345 Watt Power Supply with 56VDC & 24VDC dual output.

Features

- Compact Stand-Alone or DIN Rail form factor
- Wide 100-240VAC power input with externally accessible fuse
- Dual Output: 315W at 56VDC and 30W at 24VDC or 12VDC, Terminal Block Connectors
- Maximum output: 345 Watts
- Full compliance with IEEE 2250VDC PoE isolation requirements
- Active fan speed control based on temperature
- Front panel LED to indicate the status of power supply, fan faults and temperature
- 2-Pin alarm DC relay output with 5 event monitoring:
 - Fan tachometer monitoring for low speed or lock conditions
 - Over or under temperature
 - 12/24V output out of spec

Output 1	Voltage	56V (terminal block)
	Regulation	+/- 2%
	Current Rating	5.7A
	Power Rating	315W
Output 2	Voltage	24V (terminal block) (5624T), 12V (terminal block) (5612T)
	Regulation	+/- 5%
	Current Rating	1.25A
	Power Rating	30W
Input Voltage Range	100-240VAC	
Input Frequency Range	47 - 63 HZ	
Power Consumption	4A at 120 VAC (typical)	
Dimensions	Width: 6.25" [159 mm] x Depth: 6.45" [164 mm] x Height: 1.75" [44 mm]	
Weight	1.8 lbs. [0.82 kg]	
MTBF	623,377 hrs	
Operating Temp.	-20°C to +70°C (restricted); -20°C to +50°C (unrestricted)	
Storage Temp.	-30°C to +70°C	
Operating Humidity	5% to 95% (non-condensing)	
Certifications	EMI: EN55032 Class A, EN55024. Safety: EN60950, UL 60950	
Warranty	5 Years	

Power Cord Included: To order the corresponding country-specific power cord, add the extension to the end of the SKU: PS-DC-DUAL-5624T-NA= North America, AL = North America locking right angle, LA = Latin America, EU = Europe, UK = United Kingdom, SA = South Africa, JP = Japan, OZ = Australia, BR = Brazil.



4 Initial Switch Setup

Initial Switch Setup via Web Browser

For the initial configuration stage, you must reconfigure your PC's IP address and subnet mask so as to make sure the PC can communicate with the switch. After changing PC's IP address (for example, 192.168.1.250), then you can access the Web interface of the switch using the switch's default IP address as shown below.

The initial switch setup via web browser procedure is as follows:

Note: The switch's factory default IP address is **192.168.1.77** and the factory default Subnet Mask is **255.255.255.0**.

1. Power up the PC that you will use for the initial configuration. Make sure the PC has an Ethernet RJ45 connector to be connected to the switch via standard Ethernet LAN cable.
2. Reconfigure the PC's IP address and Subnet Mask as below, so that it can communicate with the switch.:
3. Power up the switch to be initially configured and wait until it has finished its start-up processes.
4. Connect the PC to any port on the switch using a standard Ethernet cable, and check the port LED on the switch to make sure the link status of the PC is OK.
5. Run a Web browser on the PC; enter the factory default IP address, to access the switch Web UI.

If your PC is configured correctly, you will see the login page of the switch as shown below.



Web Interface Login page

If you do not see the above login page, perform these steps:

- Refresh the web page.
 - Check to see if there is an IP conflict issue.
 - Clean browser cookies and temporary internet files.
 - Check your PC settings again and repeat step 2.
6. Enter the factory default username (**admin**) and password (**admin**) in login page.
 7. Click "Login" to log into the switch. See the *SISPM1040-582-LRT Web User Guide* for more information.

Initial Switch Configuration via CLI

The CLI (Command Line Interface) can be accessed via telnet or SSH. A brief description of the network connection is provided below. The RJ-45 cable is used for connecting a terminal or terminal emulator to the Switch's RJ-45 port to access the CLI.

1. Attach the RJ-45 serial port on the switch's front panel which used to connect to the switch for console configuration.
2. Attach the other end of the DB-9 cable to an ASCII terminal emulator or PC Com-1, 2 port (e.g., a PC running Microsoft Windows HyperTerminal), [HyperTerminal](#) for Windows 10, [HyperACCESS](#) (successor to HyperTerminal), or [PuTTY](#) (requires a PC COM port).
3. At the "Com Port Properties" Menu, configure the parameters Baud rate=115200, Stop bits=1, Data bits=8, Parity=N, Flow control=none.

For managing other switch features, see the *SISPM1040-582-LRT CLI Reference* for details.

5 Troubleshooting, Support, and Compliance

Troubleshooting

This section provides steps to troubleshoot problems by taking actions based on the suggested solutions.

General Troubleshooting

Most problems are caused by the following situations. Check for these items first when starting troubleshooting:

1. Make sure your switch model supports the feature or function attempted; see [Key Features](#) on page 6.
2. Verify the install process; see chapter 3. [Installation](#) on page 18.
3. Troubleshoot connected network devices to pinpoint the problem to the switch.
4. Connecting to devices that have a fixed full- duplex configuration. Make sure all devices connected to the Switch devices are configured to auto negotiate or are configured to connect at half duplex.
5. Faulty or loose cables. Look for loose or obviously faulty connections. If they appear to be OK, make sure the connections are snug. If that does not correct the problem, try a different cable.
6. Non-standard cables. Non-standard and miswired cables may cause network collisions and other network problems and can seriously impair network performance. Use a new correctly wired cable. A cable tester is a recommended tool for every Ethernet network installation.
7. Improper Network Topologies. Make sure you have a valid network topology. If you no longer experience the problems, the new topology is probably at fault. Also, make sure your network topology contains no data path loops.
8. Check the port configuration. A port on your Switch may not be operating as you expect because it has been put into a “blocking” state by Spanning Tree, GVRP (automatic VLANs), or LACP (automatic trunking). Note that the normal operation of the Spanning Tree, GVRP, and LACP features may put the port in a blocking state. Make sure the port was not configured as disabled via software.
9. SYS LED is Off. Check connections between the switch, the power cord and the wall outlet. Contact Tech Support for assistance. See [LED Troubleshooting](#) below.
10. Link LED is Off. Verify that the switch and attached device are powered on. Be sure the cable is plugged into the switch and corresponding device. If the switch is installed in a rack, check the connections to the punch-down block and patch panel. Verify that the proper cable type is used, and its length does not exceed specified limits. Check the adapter on the attached device and cable connections for possible defects. Replace the defective adapter or cable if necessary.
11. For PD power up failures or power cycling, verify that the power supply is set to Vout of 57 VDS. See [Connecting Powered Devices \(PDs\)](#) on page 26.
12. Check the Release Notes for known issues; check the SISPM1040-582-LRT [product page](#) for newer firmware to update to.
13. Contact Tech Support for assistance.

LED Troubleshooting

The following table provides information for users to easily troubleshoot problems by taking actions based on the suggested solutions within.

Table 7: Troubleshooting

Symptom	Possible Cause	Suggested Solutions
SYSTEM LED is Off	The switch is not receiving power.	<ol style="list-style-type: none"> 1. Check if correct power cord is connected firmly to the switch and to the DC outlet socket. 2. Perform power cycling the switch by unplugging and plugging the power cord back into the switch. 3. If the LED is still off, try to plug power cord into different DC outlet socket to make sure correct DC source is supplied.
Port Up Status LED is Off	The port is not connected or the connection is not working.	<ol style="list-style-type: none"> 1. Check if the cable connector plug is firmly inserted and locked into the port at both the switch and the connected device. 2. Make sure the connected device is up and running correctly. 3. If the symptom still exists, try a different cable or different port, in order to identify if it is related to the cable or specific port. 4. Check if the port is disabled in the configuration settings via Web user interface.
Port Down Status LED is Off	The port is not supplying power	<ol style="list-style-type: none"> 1. Check if the cable connector plug is firmly inserted and locked into the port at both the switch and the connected device. 2. Make sure the correct Ethernet cables are used. 3. If the symptom still exists, try a different cable or different port, in order to identify if it is related to the cable or specific port. 4. Check if the port is disabled in the configuration settings via Web user interface.

PoE Modes and Compliance

PoE History

PoE first emerged to solve the problem of powering Voice over Internet Protocol (VoIP) phones. PoE gained momentum in 2001 and 2002, when WAP makers, and other manufacturers took advantage of the technique. IEEE 802.3af can use a single standard RJ45 connector and CAT 5 (or even CAT 3) cable.

PoE+ (PoE Plus) provides extended support for new end devices with higher power requirements. The IEE 802.3at standard provides up to 30 W of power to include newer end devices such as IEEE 802.11n wireless access points, surveillance cameras, etc.

PoE++ (IEEE 802.3bt): As manufacturers continued to advance the use of PoE, another option became available for PoE with greater output. PoE++ delivers up to 60 watts of power using the 802.3bt standard. PoE++ is delivered using the simultaneous transmission of Mode A and Mode B. PoE++ is ideal for IP surveillance cameras that require more throughput or a various other equipment such as LCD displays, computer workstations, and biomedical equipment. Min. cable type Cat5e; recommend Cat 6A cabling.

PoE Standards Comparison

PoE Type 1 / PoE+ Type 2 / 802.3bt Type 3 / 802.3bt Type 4

Property	802.3af PoE (Type 1)	802.3at PoE+ (Type 2)	802.3bt Type 3	802.3bt Type 4
Power Available at PD	12.95 W	25.50 W	51 W	71 W
Max. Power from PSE	15.40 W	30.0 W	60 W	100 W
Voltage Range (at PSE)	44.0 – 57.0 V	50.0 – 57.0 V	50.0 – 57.0 V	52.5 – 57.0 V
Voltage Range (at PD)	37.0 – 57.0 V	42.5 – 57.0 V	42.5 – 57.0 V	41.1 – 57.0 V
Max. current	350 mA	600 mA per mode	1200 mA	1371 mA
Max. cable resistance	20 ohms (Cat 3)	12.5 ohms (Cat 5)	6.25 ohms	6.25 ohms
Power management	3 power class levels negotiated by signature	4 power class levels negotiated by signature or 0.1 W steps negotiated by LLDP	3 power class levels negotiated by signature or 0.1 W steps negotiated by LLDP	0.1 W steps negotiated by LLDP
Supported cabling	Cat 3 and Cat 5	Cat 5	Cat 5	Cat5e or Cat 6; Cat 6A recommended
Supported modes	Mode A (endspan), Mode B (midspan)	Mode A, Mode B	Mode A, Mode B, 4-pair mode	4-pair mode

PoE Types

See below for PoE type, PD power, cabling, and classes.

PD Type	PD Power	Cable Category	Classes
Type 1	up to 12.95	Cat 3 and Cat 5	2 pairs class 1-2
Type 2	up to 25.5W	Cat 5	2 pairs class 3-4
Type 3	40 – 51 W	Cat5e	4 pairs class 5-6
Type 4	62 – 71 W	Cat5e	4 pairs class 7-8

Type 1 : Also known as PoE, 2-pair PoE. Related standard: IEEE 802.3af. Maximum power to port: 15.4W. PoE Type 1 utilizes two pairs to connect many types of lower-powered devices to the network. Based on the initial IEEE 802.3af-2003 standard, it provides up to 15.4W of DC power to each PoE port (up to 12.95W of power for each device). PoE Type 1 can support devices such as VoIP phones, sensors/meters, wireless access points with two antennas and simple, static surveillance cameras (no pan, tilt or zoom).

Type 2 : Also known as PoE+, PoE Plus. Related standard: IEEE 802.3at. Maximum power to port: 30W. Higher-powered devices are connected to the network using PoE Type 2, based on the IEEE 802.3at-2009 standard. It is backward compatible (supports PoE Type 1 devices) and provides 30W of DC power to each PoE port (up to 25.5W of power for each device). PoE Type 2 can support devices such as more complex surveillance cameras that pan, tilt or zoom, as well as wireless access points with six antennas, LCD displays, biometric sensors, and tablets.

Type 3 : Also known as 4-pair PoE, 4P PoE, PoE++, UPOE. Related standard: IEEE 802.3bt. Maximum power to port: 60W. PoE Type 3 uses all four pairs in a copper cable. Currently in development with IEEE 802.3bt Type 3 Work Group, it is projected to be ratified in early 2017. It provides 60W of DC power to each PoE port (up to 51W of power for each device). PoE Type 3 can support devices such as videoconferencing system components and building management devices.

Type 4: Also known as higher-power PoE. Related standard: IEEE 802.3bt. Maximum power to port: 100W. Growing power requirements of network devices are pushing the need for higher power delivered through network cabling – which is where PoE Type 4 comes into play. It provides up to 100W of DC power to each PoE port (up to 71W of power for each device). PoE Type 4 can support devices such as laptops and TVs.

PoE Classes

PoE Classification is where the PSE detects the PD's power requirements by using Physical Layer Classification or LLDP. The IEEE 802.3bt draft standard specifies mutual identification to address four-pair operation. Additional clauses were added, defining the following:

Class	PSE Output Power[W]	PD Input Power[W]	PD Type	Standard
0	15.4	12.95	1	IEEE 802.3af
1	4	3.84	1	
2	7	6.49	1	
3	15.4	12.95	1	
4	30	25.5	2	IEEE 802.3at
5	45	40	3	IEEE 802.3bt
6	60	51	3	
7	75	62	4	
8	90	73	4	

PoE Deployment Environments A and B

IEEE802.3at-2009 defines two deployment environments in section 33.4.1:

Environment A: when both PSE and PD are located indoors, inside the same building. In this environment, there has to be electrical isolation between the PoE circuitry and the data circuitry inside a PSE. Multi-port PSE's can all share the same ground isolation. Environment A is therefore an *indoor PSE – indoor PD* environment (a.k.a. *indoor/indoor*).

Environment B: when the PSE and PD are not located in the same building. In this environment there needs to be electrical isolation between PoE and data, as well as between every port in a multi-port PSE. This isolation between ports requirement de facto determines a completely separate power supply per port, which makes multi-port PSE's for outdoor PD deployment impractical. Environment B is therefore an *indoor PSE - outdoor PD* (a.k.a. *indoor/outdoor*) or outdoor PSE-outdoor PD (a.k.a. *outdoor/outdoor*) environment.

This means only single-port PSE's should normally be used when PD's are deployed outdoors. In summary, the PD-PSE environment is one of these three combinations:

1. PoE Source is indoor, PD is indoor (Env. A)
2. PoE Source is indoor, PD is outdoor (Env. B)
3. PoE Source is outdoor, PD is outdoor (Env. B)

Option 3 is the most challenging environment since both the PD and PSE are installed outdoors. **Caution:** The switch is an indoor device. If it is to be used with outdoor devices such as outdoor IP cameras or outdoor Wi-Fi APs, then you are strongly suggested to install a surge protector or surge suppressor in order to protect the switch. The switch is compliant with 802.3at in Environment A when using an isolated power supply. For 802.3at Environment B applications, i.e. building to building, copper to copper endpoint connections: 1) use an Ethernet network isolator module (PoE disabled), or 2) use mid-span injector(s) between this switch's PSE port and link partner PD port.

Mode A vs. Mode B

Alternative A, also known as Mode A, uses the data pairs of an Ethernet link to deliver power. Data Pairs include pins 1,2 and 3,6. PSEs using Mode A supply a positive voltage to pins 1 and 2. Alternative B, also known as Mode B, uses the spare pairs to deliver power. Spare Pairs include pins 4,5 and 7,8.

802.3af/at Standard "compliant" vs "compatible" PDs

Knowing the difference between PoE "compliant" devices and "compatible" devices can help avoid interoperability and connectivity issues. Compliant and compatible PoE devices are not held to the same 802.3af/at standard:

- 802.3af/at "compliant" PDs fulfill the IEEE strict requirement to support both Mode A and Mode B power modes.
- 802.3af/at "compatible" PDs typically can provide power using only Mode B.

Typical PD Power Requirements

- 1.8 Watts: Lantronix M/GE-ISW-SFP-01-PD (Class 1 Powered Device (0.44 Watts - 3.84 Watts)).
- 13W: IP Camera, VoIP Phone, Wireless Access Point, Networked Audio.
- 30W: IP Telephone, WiMAX Access Point, PTZ Camera, Remote Computer Terminal.
- 60W : Door Access System, Video Phone, Thin Client.
- 100W: Digital Signage Display, Point-of-Sale System, LCD TV, Computer Monitor.
- 200W: Larger TV, Larger Display, Larger Monitor, Laptop.

After eliminating basic network factors, ask your PD vendor for the PD's power supply mode and polarities supported and exact power consumption.

Calculate PoE Power Budget

To calculate how many 802.3at devices the unit supports, divide the Total PoE Budget (130 Watts) by 30 Watts. To calculate the maximum number of 802.3af devices, divide the Total PoE Budget (130 Watts) by 15.4 Watts.

Mixing POE and Non-POE Devices

You can mix POE and non-POE devices on the same POE switch (i.e., you can put PCs on the same POE switch as a SIP phone or a VOIP phone). The PSE (your switch) will only send power if requested by the PD.

Ethernet and PoE Intra-Building Cabling Warnings

1. Ethernet cables are intended for intrabuilding use only. Connecting your switch directly to Ethernet cables that run outside the building in which the switch is housed will void the user's warranty and could create a fire or shock hazard.
2. PoE cables are intended for intrabuilding use only. Connecting your switch directly to PoE cables that run outside the building in which the switch is housed will void the user's warranty and could create a fire or shock hazard.
3. For outdoor PoE applications, we recommend using Lantronix SI-IES-1200-LRT Unmanaged Hardened PoE+ Injector or SI-IES-111D-LRT Unmanaged Hardened PoE+ Injector/Converter Use of any other PoE injector will void the user's warranty and could create a fire or shock hazard.

Legacy PD Detection / Capacitor Detection

Legacy PDs refers to powered devices manufactured before the IEEE standard was finalized and do not have the expected PD signature required by the PSE's detection signal. Such PDs usually feature large capacitance as the detection signature that does not completely comply with the 802.3af specs. By enabling this option, the switch will probe for legacy PDs and if a legacy PD is detected, the switch will provide power to the PD.

PoE ++ Connectivity, Arcing, and Temperature Issues

- PoE is not live until powered device (PD) and powered sourcing equipment (PSE) handshake.
- When unplugging live PoE, an arc (or spark) occurs between plug and jack contacts.
- Arcing occurs with ALL mated PoE connections.
- Ensure jack meets IEC 60512-99-001 for compliance.
- Ambient jack temperature must be 5 deg. C below maximum jack operating temperature. To operate in 60 deg. C ambient, you need a 65 deg. C rated jack.

See the BICSI webpage for your particular type of PoE (e.g., for [PoE++](#)). See the [ANSI/NECA/BICSI 568-2006 Standard](#) for Installing Commercial Building Telecommunications Cabling. ANSI/NECA/BICSI 568 describes minimum requirements and procedures for installing the infrastructure for telecoms, including balanced twisted-pair copper cabling and optical fiber cabling that transport telecommunications signals (e.g., voice, data, and video). The 2008 NEC standard is a safety code widely adopted in the USA as minimum required safety rules for the electrical industry. The 2008 NEC points to the ANSI/NECA/BICSI 568 standard as a best practices source document.

PoE/PoE+/PoE++ Comparison Chart

The table below compares the three types of PoE supported.

Type	Standards	Max. Current	Twisted pairs used	Power at Source	Power at Device	Max. Data Rate	Standard Ratified
PoE	IEEE 802.3af (802.3at Type 1)	350 mA	2 pairs	15.4 W	13 W	1000Base-T	2003
PoE+	802.3at Type 2	600 mA	2 pairs	30 W	25.5 W	1000Base-T	2009
PoE++	Proposed IEEE 802.3bt Type 3 / Proposed IEEE 802.3bt Type 4	600 mA / 900 mA	4 pairs	60 W / 90 W	51 W / 71.3 W	10GBase-T	Coming in 2018

Notes from Draft Standard for Ethernet Amendment 2: PoE over 4 Pairs (IEEE 802.3bt)

See IEEE 802.3, Clause 145. IEEE Draft and approved standards are copyrighted by IEEE under U.S. and international copyright laws.

Amendment 2 – This amendment includes changes to IEEE Std. 802.3-2018 and adds Clause 145, Annex 145A, and Annex 145B. This amendment adds power delivery using all four pairs in the structured wiring plan, resulting in greater power being available to end devices and adds a mechanism to better manage the available power budget.

1.4.491a Type 3 PD: A single-signature PD that requests Class 1 to Class 6, or a dual-signature PD that requests Class 1 to Class 4 on both Modes, during Physical Layer classification. Additionally, the PD implements Multiple-Event classification, and accepts power on both Modes simultaneously.

1.4.491b Type 3 PSE: A PSE that supports up to Class 6 power levels, supports short MPs, and may support 4-pair power.

1.4.491c Type 4 PD: A single-signature PD that requests Class 7 or Class 8, or dual-signature PD that requests Class 5 on at least one Mode, during Physical Layer classification. Additionally, the PD implements Multiple-Event classification, is capable of Data Link Layer classification, and accepts power on both Modes simultaneously.

1.4.491d Type 4 PSE: A PSE that supports at least Class 7 power levels, in addition to lower PD Classes, short MPs, and 4-pair power.

IEEE 802.3bt Power Input Ripple and Noise Specification

$f < 500$ Hz	V_{Noise}	V_{pp}	0.5
500 Hz to 150 kHz			0.2
150 kHz to 500 kHz			0.15
500 kHz to 1 MHz			0.1

Term Definitions

From Draft Standard for Ethernet Amendment 2: Power over Ethernet over 4 Pairs (IEEE 802.3bt) (See IEEE 802.3, Clause 145.)

Ampacity: the maximum current, in ampere, that a conductor can carry continuously under the conditions of use without exceeding its temperature rating.

Dual-signature PD: A PD that has independent detection signatures, class signatures, and maintains power signatures on each pairset.

Link section: the portion of the link between the PSE Power Interface (PI) and the PD PI.

Pairset: Either of two valid 4-conductor connections, Alternative A or Alternative B, as listed in IEEE 802.3, 145.2.4. The PSE Alternative A and Alternative B connections are referred to as Mode A and Mode B, respectively, at the PD.

Power Sourcing Equipment (PSE): A DTE or midspan device that provides power to a single link section which may also carry data.

Single-signature PD: A PD that simultaneously shares the same detection signature, class signature, and maintains power signature between both pairsets.

Type 1 PD: A PD that requests Class 0 to Class 3 during Physical Layer classification and that is not a PoDL PD.

Type 1 PSE: A PSE that supports Class 0 to Class 3 power levels and provides power over 2 pairs.

Type 2 PD: A PD that requests Class 4 during Physical Layer classification, supports 2-Event Classification, and supports Data Link Layer classification.

Type 2 PSE: A PSE that supports Class 0 to Class 4 power levels and provides power over 2 pairs.

Type 3 PD: A single-signature PD that requests Class 1 to Class 6, or a dual-signature PD that requests Class 1 to Class 4 on both Modes, during Physical Layer classification. Additionally, the PD implements Multiple-Event classification, and accepts power on both Modes simultaneously.

Type 3 PSE: A PSE that supports up to Class 6 power levels, supports short MPs, and may support 4-pair power.

Type 4 PD: A single-signature PD that requests Class 7 or Class 8, or a dual-signature PD that requests Class 5 on at least one Mode during Physical Layer classification. Additionally, the PD implements Multiple-Event classification, is capable of Data Link Layer classification, and accepts power on both Modes simultaneously.

Type 4 PSE: A PSE that supports at least Class 7 power levels, in addition to lower PD Classes, short MPS, and 4-pair power.

General Safety

All equipment subject to this clause shall conform to IEC 60950-1 or IEC 62368-1. In particular, the PSE shall be classified as a Limited Power Source in accordance with IEC 60950-1 or IEC 62368-1 Annex Q.

Equipment shall comply with all applicable local and national codes related to safety.

Network Safety

This subclause sets forth a number of recommendations and guidelines related to safety concerns. The list is neither complete nor does it address all possible safety issues. The designer is urged to consult the relevant local, national, and international safety regulations to verify compliance with the appropriate requirements. LAN cabling systems described in this clause are subject to at least four direct electrical safety hazards during their installation and use. These hazards are as follows:

- a) Direct contact between LAN components and power, lighting, or communications circuits.
- b) Static charge buildup on LAN cabling and components.
- c) High-energy transients coupled onto the LAN cabling system.
- d) Voltage potential differences between safety grounds to which various LAN components are connected.

Such safety hazards should be avoided or appropriately protected against for proper network installation and performance. In addition to provisions for proper handling of these conditions in an operational system, special measures should be taken to verify that the intended safety features are not negated during installation of a new network or during modification of an existing network.

Patch Panel Considerations

It is possible that the current carrying capability of a cabling cross-connect may be exceeded by a PSE. The designer should consult the manufacturer's specifications to verify compliance with the appropriate requirements.

Electromagnetic Emissions

The PD and PSE powered cabling link shall comply with applicable local and national codes for the limitation of electromagnetic interference.

Temperature and Humidity

The PD and PSE powered cabling link segment is expected to operate over a reasonable range of environmental conditions related to temperature, humidity, and physical handling. Specific requirements and values for these parameters are beyond the scope of the standard.

Labeling

From Approved Draft Standard for Ethernet Amendment 2: Power over Ethernet over 4 Pairs (**IEEE 802.3bt**):

It is recommended that the PSE or PD (and supporting documentation) be labeled in a manner visible to the user with at least the following parameters:

- a) Power classification and power level in terms of maximum current drain over the operating voltage range, 36 V to 57 V, *applies for PD only*.
- b) Port type (e.g., 100BASE-TX, TIA Category, or ISO Class).
- c) Any applicable safety warnings.
- d) "PSE" or "PD" as appropriate.
- e) Indicate "single-signature PD" or "dual--signature PD" as appropriate.
- f) Type (e.g., "Type 3" or "Type 4").

Product Labeling

The packaging label and the product label have important information to record that will be helpful when contacting Technical Support.



Box Label

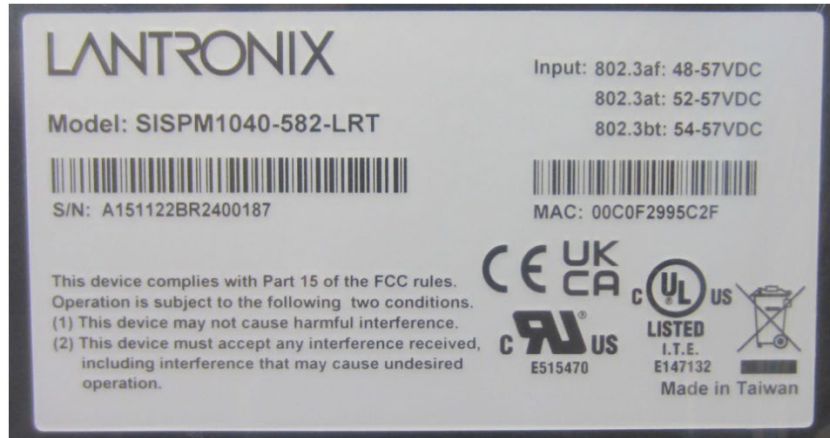

Device Label

Recording Device and System Information

After performing the troubleshooting procedures, and before calling or emailing Technical Support, please record as much information as possible to help the Tech Support Engineer.

1. Select the Configuration > System > Information menu path. From the CLI, use the show commands to gather the information below or as requested by the Tech Support Engineer.

2. Model Name: _____ Serial Number (S/N): _____
Hardware Version: _____ Mechanical Version: _____
Firmware Version: _____ System Date: _____

3. LED Status: _____

4. Provide additional information to your Tech Support Engineer. See the "Troubleshooting" section above.

Your Lantronix service contract number: _____

Describe the failure: _____

A description of any action(s) already taken to resolve the problem (e.g., changing mode, rebooting, etc.):

The model #, serial # and rev of all involved Lantronix products in the network: _____

A description of your network environment (PDs, cable type, etc.): _____

The device history (i.e., have you returned the device before, is this a recurring problem, etc.): _____

Any previous Return Material Authorization (RMA) numbers: _____

Attach any screen captures, config files, diagnostic results, server reports, etc. _____

For Lantronix Warranty Policy & Procedure information go to <https://www.lantronix.com/technical-support/warranty/>.

Compliance Information

FCC Regulations

This equipment has been tested and found to comply with the limits for a Class A digital device, pursuant to part 15 of the FCC rules. These limits are designed to provide reasonable protection against harmful interference when the equipment is operated in a commercial environment. This equipment generates, uses, and can radiate radio frequency energy and, if not installed and used in accordance with the instruction manual, may cause harmful interference to radio communications.

Operation of this equipment in a residential area is likely to cause harmful interference, in which case the user will be required to correct the interference at the user's own expense.

This device complies with part 15 of the FCC Rules. Operation is subject to the following two conditions: (1) This device may not cause harmful interference, and (2) this device must accept any interference received, including interference that may cause undesired operation.

Canadian Regulations

This digital apparatus does not exceed the Class A limits for radio noise for digital apparatus set out on the radio interference regulations of the Canadian Department of Communications.

Le présent appareil numérique n'émet pas de bruits radioélectriques dépassant les limites applicables aux appareils numériques de la Class A prescrites dans le Règlement sur le brouillage radioélectrique édicté par le ministère des Communications du Canada.

Declaration of Conformity (DoC)

Manufacture's Name: Lantronix, Inc.

Manufacture's Address: 48 Discovery, Suite 250, Irvine, California 92618

Declares that the product: SISPM1040-582-LRT

Conforms to the following Product Regulations:

EN55032:2015 +AC:2016, Class A; CISPR 32:2015 +Cor 1:2016, Class A

AS/NZS CISPR 32:2015, Class A; EN 55024:2010

EN 61000-4-2:2009 / IEC 61000-4-2:2008 ED. 2.0

EN 61000-4-3:2006 +A1:2008 +A2:2010 / IEC 61000-4-3:2010 ED. 3.2

EN 61000-4-4:2012 / IEC 61000-4-4:2012 ED. 3.0

EN 61000-4-5:2006 / IEC 61000-4-5:2005 ED. 2.0

EN 61000-4-6:2014 / IEC 61000-4-6:2013 ED. 4.0

EN 61000-4-8:2010 / IEC 61000-4-8:2009 ED. 2.0

47 CFR FCC Part 15, Subpart B, Class A; ICES-003:2016 Issue 6, Class A; ANSI C63.4:2014

EN 62368-1:2014+A11:2017

With the technical construction on file at the above address, this product carries the CE Mark

I, the undersigned, hereby declare that the equipment specified above conforms to the above Directive(s) and Standards(s).

Place: Irvine, California

Date: April 27, 2023

Signature: *Eric Bass*

Full Name: Eric Bass

Position: Vice President of Engineering

Class I, Division 2 / classe I, division 2

Warning and Caution - Proper Installation and Operation (English)

These devices are open-type devices that are to be installed in an enclosure only accessible with the use of a tool, suitable for the environment. This equipment is suitable for use in Class I, Division 2, Groups A, B, C, and D or non-hazardous locations only. WARNING – EXPLOSION HAZARD. DO NOT DISCONNECT WHILE THE CIRCUIT IS LIVE OR UNLESS THE AREA IS FREE OF IGNITIBLE CONCENTRATIONS.

Avertissement et mise en garde - Installation et fonctionnement corrects (français)

Ces périphériques sont des périphériques de type ouvert qui doivent être installés dans un enceinte uniquement accessible à l'aide d'un outil, adapté à environnement. Cet équipement peut être utilisé dans la classe I, division 2, groupes A, B, C, et D ou des emplacements non dangereux seulement. AVERTISSEMENT - RISQUE D'EXPLOSION. NE PAS SE DÉCONNECTER LORSQUE LE CIRCUIT EST VIVANT OU À MOINS QUE LA ZONE NE SOIT LIBRE DE CONCENTRATIONS IGNIFIABLES.

High Risk Activities Disclaimer

Components, units, or third-party products used in the product described herein are NOT fault-tolerant and are NOT designed, manufactured, or intended for use as on-line control equipment in the following hazardous environments requiring fail-safe controls: the operation of Nuclear Facilities, Aircraft Navigation or Aircraft Communication Systems, Air Traffic Control, Life Support, or Weapons Systems ("High Risk Activities"). Lantronix and its supplier(s) specifically disclaim any expressed or implied warranty of fitness for such High Risk Activities.

Safety Statements

CAUTION: Circuit devices are sensitive to static electricity, which can damage the delicate electronics. Dry weather conditions or walking across a carpeted floor may cause you to acquire a static electrical charge.

To protect your device:

1. Touch the metal chassis of your computer to ground the static electrical charge before you pick up the circuit device.
2. Pick up the device by holding it on the left and right edges only.
3. If you need to use an outdoor device connected to this device with cable, then you must use an arrester on the cable between the outdoor device and this device.

Note: This switch is an indoor device; if it will be used in an outdoor environment or to connect with an outdoor device, then it must use a lightning arrester to protect the switch.

WARNING:

- Self-demolition of this product is strictly prohibited. Damage caused by self-demolition will be charged for repairing fees. See the [US EPA Electronics Donation and Recycling](https://www.epa.gov/electronics) website.
- Do not place product outdoors.
- Before installation, make sure input power supply and product specifications are compatible.
- To reduce the risk of electric shock, disconnect all AC or DC power cord and PS cables to completely remove power from the unit.
- Before importing / exporting a configuration verify the firmware version.
- After a firmware upgrade, the switch will automatically set the configuration to the latest version.

RoHS, WEEE, and Environmental Programs

See <https://www.lantronix.com/legal/rohs/>

Cautions and Warnings

Definitions

Cautions indicate that there is the possibility of poor equipment performance or potential damage to the equipment. **Warnings** indicate that there is the possibility of injury to person.

Cautions and Warnings appear here and may appear throughout this manual where appropriate. Failure to read and understand the information identified by this symbol could result in poor equipment performance, damage to the equipment, or injury to persons.

Cautions

While installing or servicing the power module, wear a grounding device and observe all electrostatic discharge precautions. Failure to observe this caution could result in damage to, or failure of the power module.

Warnings

Warning: Do not connect the power module to an external power source before installing it into the chassis. Failure to observe this warning could result in an electrical shock, even death.

WARNING: The power module has a provision for grounding. Equipment grounding is vital to ensure safe operation. The installer must ensure that the power module is properly grounded during and after installation. Failure to observe this warning could result in an electric shock, even death.

WARNING: A readily accessible, suitable National Electrical Code (NEC) or local electrical code approved disconnect device and branch-circuit protector must be part of the building's installed wiring to accommodate permanently connected equipment. Failure to observe this warning could result in an electric shock, even death.

WARNING: Turn the external power source OFF and ensure that the power module is disconnected from the external power source before performing any maintenance. Failure to observe this warning could result in an electrical shock, even death.

WARNING: Ensure that the disconnect device for the external power source is OPEN (*turned OFF*) before disconnecting or connecting the power leads to the power module. Failure to observe this warning could result in an electric shock, even death.

WARNING HOT SURFACE DO NOT TOUCH



See Electrical Safety Warnings below for Electrical Safety Warnings translated into multiple languages.

Electrical Safety Warnings

Electrical Safety

IMPORTANT: This equipment must be installed in accordance with safety precautions.

Elektrische Sicherheit

WICHTIG: Für die Installation dieses Gerätes ist die Einhaltung von Sicherheitsvorkehrungen erforderlich.

Elektrisk sikkerhed

VIGTIGT: Dette udstyr skal installeres i overensstemmelse med sikkerhedsadvarslerne.

Elektrische veiligheid

BELANGRIJK: Dit apparaat moet in overeenstemming met de veiligheidsvoorschriften worden geïnstalleerd.

Sécurité électrique

IMPORTANT: Cet équipement doit être utilisé conformément aux instructions de sécurité.

Sähköturvallisuus

TÄRKEÄÄ: Tämä laite on asennettava turvaohjeiden mukaisesti.

Sicurezza elettrica

IMPORTANTE: questa apparecchiatura deve essere installata rispettando le norme di sicurezza.

Elektrisk sikkerhet

VIKTIG: Dette utstyret skal installeres i samsvar med sikkerhetsregler.

Segurança eléctrica

IMPORTANTE: Este equipamento tem que ser instalado segundo as medidas de precaução de segurança.

Seguridad eléctrica

IMPORTANTE: La instalación de este equipo deberá llevarse a cabo cumpliendo con las precauciones de seguridad.

Elsäkerhet

OBS! Alla nödvändiga försiktighetsåtgärder måste vidtas när denna utrustning används.

**Lantronix Corporate Headquarters**

48 Discovery, Suite 250

Irvine, CA 92618, USA

Toll Free: 800-526-8766

Phone: 949-453-3990

Fax: 949-453-3995

Technical Support

Online: <https://www.lantronix.com/technical-support/>

Sales Offices

For a current list of our domestic and international sales offices, go to the Lantronix web site at www.lantronix.com/about/contact.