

# SISPM1040-582-LRT

**Managed Hardened PoE++ Switch (8) 10/100/1000Base-T PoE++ Ports + (2) 100/1000Base-X SFP Slot**

## Quick Start Guide

See the *Install Guide* for important **Cautions** and **Warnings**, Features, Specs, Back and Front Panel, LEDs, DIP Switch Settings, RESET button, Installation, Mounting, Installing SFPs, Connecting Devices, DI/DO Relay, Grounding, Connecting P1 and P2, Power Supply, Initial Config, Troubleshooting, Warranty, PoE Modes, Compliance, and Tech Support.

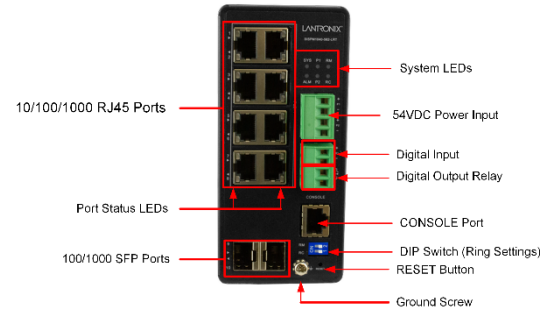

**Warning and Caution - Proper Installation and Operation (English):** These devices are open-type devices that are to be installed in an enclosure only accessible with the use of a tool, suitable for the environment. This equipment is suitable for use in Class I, Division 2, Groups A, B, C, and D or non-hazardous locations only. **WARNING – EXPLOSION HAZARD. DO NOT DISCONNECT WHILE THE CIRCUIT IS LIVE OR UNLESS THE AREA IS FREE OF IGNITIBLE CONCENTRATIONS.**

**Avertissement et mise en garde - Installation et fonctionnement corrects (français):** Ces périphériques sont des périphériques de type ouvert qui doivent être installés dans un enceinte uniquement accessible à l'aide d'un outil, adapté à environnement.

Cet équipement peut être utilisé dans la classe I, division 2, groupes A, B, C, et D ou des emplacements non dangereux seulement.

**AVERTISSEMENT - RISQUE D'EXPLOSION. NE PAS SE DÉCONNECTER LORSQUE LE CIRCUIT EST VIVANT OU À MOINS QUE LA ZONE NE SOIT LIBRE DE CONCENTRATIONS IGNIFIABLES.**

**Package Contents:** Verify you received one Switch with a Terminal Block attached, one DB-9 to RJ-45 Cable, four adhesive rubber feet, this document, and one DIN Rack mount kit.

**Front Panel:** The front panel provides the ports, LEDs, Power Input terminal block, DI/DO terminal block, CONSOLE port, DIP Switch, RESET button, and Ground screw.

**LED Indicators:** The front panel LEDs provide switch and Ring status. **Power LEDs** indicate if the switch is powered up correctly. **System LED:** indicates if the system is ready or not ready. **Alarm LED** indicates if the system is normal or not. **Ring Master LED** and **Rapid Chain LED** indicate if the Rapid Ring is ready. **Port Status LEDs** indicate the current status of each port. See the *Install Guide* for details.

**DIP Switch for Ring Settings:** The two-position DIP switch is labeled **RC** (1) (Rapid Chain) and **RM** (2) (Ring Master). The DIP switch lets you avoid having to access the Web UI or CLI to configure a ring. See the *Install Guide* for DIP switch setting details.



**RESET Button:** To reset the switch press RESET for 2~7 seconds; the SYS LED blinks green; Port status LEDs are Off. To restore to defaults, press RESET for 7~12 seconds; the SYS LED blinks green; Port status LEDs are all ON.



**Installation: Caution:** The switch is an indoor device. If used with outdoor devices such as outdoor IP cameras or outdoor Wi-Fi APs, then it is strongly suggested to install a surge protector or surge suppressor to protect the switch. Compliant with 802.3at in Environment A when using an isolated power supply. For other apps, see the *Install Guide*.

These devices are open-type devices that are to be installed in an enclosure only accessible with the use of a tool, suitable for the environment. This equipment is suitable for use in Class I, Division 2, Groups A, B, C, and D or non-hazardous locations only. **“WARNING – EXPLOSION HAZARD. DO NOT DISCONNECT WHILE THE CIRCUIT IS LIVE OR UNLESS THE AREA IS FREE OF IGNITIBLE CONCENTRATIONS. Temperature code (T-Code) – T4.**

**Grounding Screw: CAUTION:** Be sure to disconnect the Switch from the power source before installing and wiring the device. **ATTENTION:** This case must be earth grounded. No DC input may be earth grounded. Use Isolated Power Supply. **Caution:** The switch is intended to be grounded to a well-grounded mounting surface such as a metal plate. Install the grounding wire prior to connecting any other device to the Switch.

**Warning:** Turn the power off before connecting or disconnecting modules or wires. The correct power supply voltage is listed on the product label. Check the voltage of your power source to make sure that you are using the correct voltage. **Do NOT** use a voltage greater than what is specified on the product label.

**PoE++ Power Note:** The Meanwell 25160 (and other) power supplies are shipped set to 48VDC. If you unbox the PS, plug it into the Switch and then connect 60W cameras to the switch, the cameras may not power up by POE. The SISPM1040-582-LRT needs 52-57VDC to power all 8 ports. Use a small Phillips screwdriver to turn the PS +V ADJUST up to 52-57VDC.

**Caution:** PoE device components may fail due to transient voltage spikes on the PoE line. It is strongly suggested that surge suppressors be used on each PoE port, especially in areas with frequent lightning and other types of interference.

**Caution:** using PoE 'Force' mode to force the switch to send PoE to non-PoE devices can physically damage those devices.

**Installing SFP Modules:** The SFP ports should use UL Listed Optional Transceiver product, Rated 3.3Vdc, Laser Class 1. Note the proper orientation and insert the module into the SFP port.

**Connecting the DI/DO Relay:** Insert the negative (ground)/positive DI/DO Relay wires into the + and - terminals, respectively. See the *Install Guide* for more details.

**Power Connection: Warning:** Connect the power supply to the switch first, and then connect the power supply to power. Otherwise product failure may occur. **1.** Verify that power is off to the DC circuit to be attached to the switch PoE DC-input connector. This can be either AC-input or DC-input or site source DC. **2.** Place an appropriate safety flag and lockout device at the source power circuit breaker, or place a piece of adhesive tape over the circuit breaker handle to prevent accidental power restoration while you are working on the circuit. **Warning:** Hot Surface; Do Not Touch.

**Disconnection:** To disconnect switch power: **1.** Turn off power to the switch. **2.** Disconnect the cables.

**Connecting P1 and P2 Power Inputs:** Insert the negative/positive DC wires into the V- and V+ terminals, respectively. Use a small flat-blade screwdriver to tighten the wire-clamp screws on the front of the Terminal Block connector. Insert the Terminal Block connector prongs into the terminal block receptor. If the **SYS** LED is ON, the power connection is correct. See the *Install Guide* for more details.



**Initial Switch Setup via Web Browser:** For the initial setup, change your PC's IP address and subnet mask so the PC can communicate with the switch. After changing PC's IP address, you can access the switch Web UI using the switch defaults (IP = 192.168.1.77, Subnet Mask = 255.255.255.0, Gateway = 192.168.1.254, Username = admin, and Password = admin). **1.** Power up the PC that you will use for the initial configuration. **2.** Reconfigure the PC's IP address and Subnet Mask so that it can communicate with the switch. **3.** Power up the switch. **4.** Connect the PC to a port on the switch using a standard Ethernet cable. **5.** On your PC's Web browser enter the factory default IP address. The switch Login page displays. **6.** Enter the factory default username (admin) and password (admin) on the Login page. **7.** Click "Login" to log into the switch. See the *Web User Guide* for more details.

**Initial Switch Setup via CLI:** The CLI can be accessed via telnet or SSH. **1.** Attach one end of the provided DB-9 to RJ-45 Cable to the switch front panel CONSOLE port. **2.** Attach the other end of the DB-9 to RJ-45 Cable to an ASCII terminal emulator or PC COM port. **3.** At the "Com Port Properties" Menu, set Baud rate=115200, Stop bits=1, Data bits=8, Parity=N, Flow control=none. See the *CLI Reference* for more details.

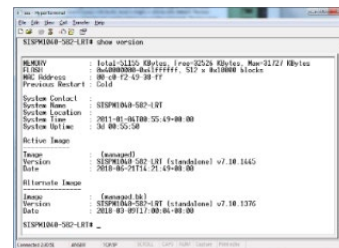

Scan for product information  
<https://www.lantronix.com/mylantronix/>

**Contact Us:** Toll Free: 800-526-8766 |  
 Phone: 949-453-3990 | Fax: 949-453-3995 |  
[Technical Support](#) | [Sales Offices](#)