



# SISPM1040-384-LRT-C and SISPM1040-362-LRT

## Managed Hardened PoE+ Switches



SISPM1040-384-LRT-C



SISPM1040-362-LRT

## Install Guide

33727 Rev. H

## Safety Warnings and Cautions

These products are not intended for use in life support products where failure of a product could reasonably be expected to result in death or personal injury. Anyone using this product in such an application without express written consent of an officer of Transition Networks does so at their own risk and agrees to fully indemnify Transition Networks for any damages that may result from such use or sale.



**Attention:** this product, like all electronic products, uses semiconductors that can be damaged by ESD (electrostatic discharge).



Always observe appropriate precautions when handling. **NOTE:** Emphasizes important information or calls your attention to

related features or instructions.  **WARNING:** Alerts you to a potential hazard that could cause personal injury.



**CAUTION:** Alerts you to a potential hazard that could cause loss of data or damage the system or equipment.

### SISPM1040-384-LRT-C and SISPM1040-362-LRT Install Guide, 33727 Rev. H

#### Record of Revisions

Rev	Date	Description of Changes
G	5/27/21	FW v7.20.0063: add API commands Set SSL Key and Get SSL Key Status. Add ping, traceroute, and activate_config API commands. Add API commands for Auto Power Reset, SNMP trap config, Show syslog, Clear syslog, and SFP port details. Fix Traceroute, SNMP Write community, and set ACL via API issues. Modify API response structure for getting firmware upgrade, active config, Ping, Traceroute, set SSL key, and login and logout status. Fix Traceroute and SNMP Trap Destination Port value issues. Add API command /api/get_config_action_status.
H	7/16/21	Replace IEC60950-1 with IEC62368-1/EN62368-1.

**Trademark notice:** All trademarks and registered trademarks are the property of their respective owners. All other products or service names used in this publication are for identification purposes only and may be trademarks or registered trademarks of their respective companies. All other trademarks or registered trademarks mentioned herein are the property of their respective holders.

**Copyright restrictions:** © 2017-2021 Transition Networks, Inc. All rights reserved. No part of this work may be reproduced or used in any form or by any means (graphic, electronic, or mechanical) without written permission from Transition Networks. Address comments on this product or manual to: **Transition Networks Inc.** 10900 Red Circle Drive, Minnetonka, MN 55343 tel: +1.952.941.7600 | toll free: 1.800.526.9267 | fax: 952.941.2322 | [sales@transition.com](mailto:sales@transition.com) | [techsupport@transition.com](mailto:techsupport@transition.com) | [customerservice@transition.com](mailto:customerservice@transition.com)

# Contents

- Safety Warnings and Cautions .....2**
- 1. Introduction.....5**
  - Product Descriptions ..... 5
  - Ordering Information ..... 5
  - Manual Overview ..... 6
  - Front Panel ..... 6
  - LED Descriptions..... 7
  - Front Panel 2-Position DIP Switch ..... 10
  - Rings Support ..... 11
  - RESET Button ..... 12
  - Front Panel Ground Screw..... 12
- 2. Installing the Switch .....13**
  - Package Contents ..... 13
  - Unpacking..... 13
  - Desktop Mounting..... 13
  - DIN Rail Mounting ..... 14
  - Wall Mounting (Optional)..... 15
  - Connecting Copper Ports..... 16
  - Installing SFP Modules..... 16
  - Connecting the DI/DO Relay Wires..... 17
  - Connecting to DC Power..... 19
    - Power Connection ..... 20
    - Power Disconnection ..... 20
- 3. Initial Switch Configuration .....21**
  - Initial Switch Configuration via Web Browser ..... 21
    - Initial Switch Configuration Procedure ..... 21
  - Connect the Switch to a Windows 10 PC ..... 22
  - Initial Switch Configuration via CLI ..... 23
- 4. Troubleshooting.....24**
  - Basic Troubleshooting ..... 24
  - Troubleshooting LED Indications ..... 25
  - LED Summary..... 26
  - PoE Modes and Compliance ..... 27

- Troubleshooting PoE Problems..... 29
- Related Manuals ..... 31
- Device Label and Packaging Label ..... 31
- Record Device and System Information ..... 32
- 5. Features and Specifications ..... 33**
  - Key Features ..... 33
  - Software Features..... 35
  - MTBF Specifications ..... 38
  - Shared Features..... 39
  - Shared Certifications and Compliance ..... 40
  - Cable Specifications..... 40
  - Power Supply Features and Specifications ..... 40
  - Industrial Power Supply 25105..... 41
  - Industrial Power Supply 25104..... 42
    - Power Supply Built-in DC OK Relay Contact..... 43
    - Power Supply Voltage Adjustment ..... 43
- 6. Regulatory and Safety Information ..... 45**
  - Compliance and Safety Statements..... 45
  - Declaration of Conformity ..... 45
  - High Risk Activities Disclaimer ..... 46
  - Cautions and Warnings..... 46
  - Electrical Safety Warnings ..... 46
  - Class I Division 2 ..... 48
- 7. Service, Warranty & Tech Support ..... 49**
  - Warranty..... 49
  - Contact Us ..... 50

# 1. Introduction

## Product Descriptions

Transition Networks [SISPM1040-384-LRT-C](#) is a fully managed PoE+ switch suitable for connecting and powering devices in hardened environments. It can supply up to 30 Watts per port on all eight ports simultaneously.

Transition Networks [SISPM1040-362-LRT](#) is a fully managed PoE+ switch suitable for connecting and powering devices in hardened environments. It can supply up to 30 Watts per port on all four PoE ports simultaneously.

The SISPM1040-362-LRT and SISPM1040-384-LRT-C differ mainly in port count as noted in this manual.

These switches include embedded Device Management System (DMS) software that provides the advanced tools necessary for total management of all IP addressable devices. The unique DMS provides security integrators with lower overall cost, less downtime and easier management of the entire PoE+ network.

These switches are hardened switches certified to operate reliably in harsh environments such as factory floors, outdoor enclosures, or other challenging environments. These switches are appropriate for use in Hazardous locations, Railway, Marine, Transportation, and Substation environments.

## Ordering Information

#	Description
<b>SISPM1040-362-LRT</b>	Managed Hardened PoE+ Switch; provides (4) 10/100/1000Base-T PoE+ ports + (2) 10/100/1000Base-T ports + (2) 100/1000Base-X SFP slots and one RJ45 Console port.
<b>SISPM1040-384-LRT-C</b>	Managed Hardened PoE+ Switch; provides (8) 10/100/1000Base-T PoE+ RJ45 ports + (4) 1000/1000Base-X SFP ports and one RJ45 Console port.
<b>Optional Accessories</b>	(sold separately)
25104	Optional Industrial Power Supply: Input: 85-264 VAC, 124-370 VDC. Output: 48~55 VDC, 5.0A, 240 Watts. Sold separately.
25105	Optional Industrial Power Supply: Input: 85-264 VAC, 124-370 VDC. Output: 48~55 VDC, 2.5A, 120 Watts. Sold separately.
PS-DC-DUAL Series	Optional Supply: Input: 100-240 VAC, Dual 56VDC + 12 or 24V output. Sold separately.
WMBH-01	Wall Mount Bracket for SISPM1040-384-LRT-C and SISPM1040-362-LRT. Sold separately.
DRBH-01	Din Rail Bracket. Sold separately.
SFP Modules	Transition Networks offers a full line of small form factor pluggable (SFP) transceivers. For more information, see the TN <a href="#">SFP webpage</a> . Sold separately.
EDCA-DIO-01	Enclosure Door Contact Alarm. Sold separately.
OCA-P181610	18x16x10" Polycarbonate Enclosure. Sold separately.

## Manual Overview

This manual describes how to install, configure, and troubleshoot the PoE+ Switches, including how to:

- Install the switch
- Check switch status by reading the LED indicators
- Reset the switch to restore the switch to factory defaults
- Use a Web browser to initially configure the switch
- Troubleshoot the switch

## Front Panel

The switch front panel provides the ports, LEDs, DIP switch, RESET button, etc. as shown below.

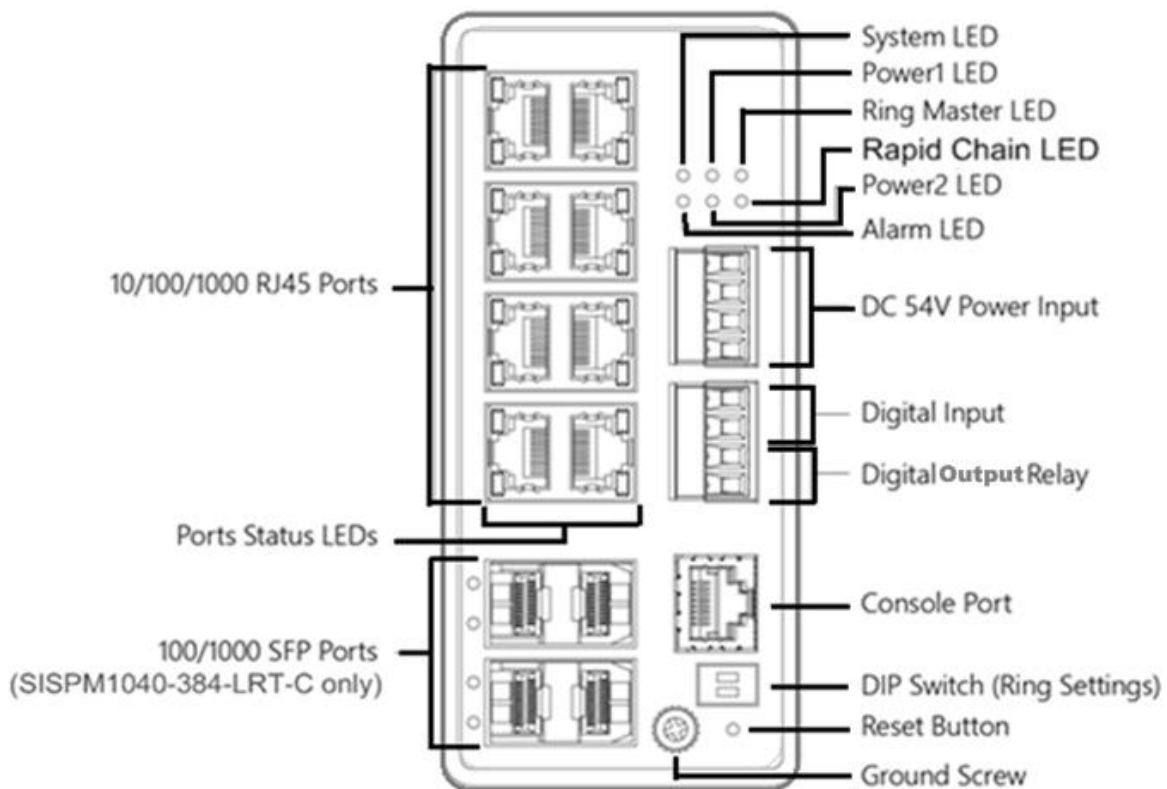

Figure 1: Front Panel

## LED Descriptions

The front panel LEDs provide switch status as follows:

**SYS (System) LED:** indicates if the system is ready or not.

**P1 and P2 (Power LEDs):** indicate whether the switch is powered up correctly.

**ALM (Alarm) LED:** indicates if the system is operating normally.

**RM (Ring Master) LED:** indicates if Ring Master(s) or Slave is enabled.

**RC (Rapid Chain) LED:** indicates the status of the Rapid-Chain.

**Port Status LEDs:** indicate the current status of each port. Check these LEDs to determine the port status.



The following tables detail the functions and descriptions of these LED indicators.

**Table 1: Power LEDs**

LED	Color	State	Description
P1 (Power1)	Green	On	The switch is powered ON correctly.
		Off	The switch is not receiving power from power1.
P2 (Power2)	Green	On	The switch is powered ON correctly.
		Off	The switch is not receiving power from power2.

**Table 2: System LED**

LED	Color	State	Description
SYS (System)	Green	On	The switch is ready.
		Off	The switch is not ready.

**Table 3: Alarm LED**

LED	Color	State	Description
ALM (Alarm)	Red	On	An abnormal state, such as temperature, voltage, or DC power1/2 was detected in the switch.
		Off	The system is normal.

## ALM (Alarm) LED

The **ALM** (Alarm) LED lights if the monitored temperature or internal voltages are exceeded.

Issue critical stage for High / Low **Voltage** alarm (Power A or B Voltage)

Lit Alarm LED in RED Color if Test-point (max) < Volts or if Test-point (min) < Volts.

V1 (PHY, TTL, LED, SFP): (max: 3.465V, min: 3.135V) (+- 5%)

V2 (MAC): (max: 2.625V, min: 2.375V) (+- 5%)

V3 (MAC, DDR): (max: 1.575V, min: 1.425V) (+- 5%)

V4 (MAC): (max: 1.05V, min: 0.95V) (+- 5%)

Issue critical stage for High **Temperature** alarm: Lit Alarm LED in RED Color if Test-point (max) < temperature max: 100°C.

You can view temperature and voltage settings at **Monitor > Port > SFP Detail Info**.

You can view and configure current trap event severity parameters via the Web Interface at **Configuration > System > Alarm Notification > Trap Event Severity**. See the *Web User Guide* for more information.





Check the port status by reading the LED behaviors per the table below.

**Table 4: Port Status LEDs**

LED	Color	State	Description
RJ45 Ports UP *	Green	On	The port is enabled and has established a link to the connected device, and the connection speed is 1000Mbps.
	Green	Blinking	The port is transmitting/receiving packets, and the connection speed is 1000Mbps.
	Amber	On	The port is enabled and has established a link to the connected device, and the connection speed is 10/100Mbps.
	Amber	Blinking	The port is transmitting/receiving packets, and the connection speed is 10/100Mbps.
	--	Off	The port has no active network cable connected, or it has not established a link to a connected device. Otherwise, the port may have been disabled via the switch user interface.
RJ45 Ports Down *	Green	On	The port is enabled and supplying power to the connected device.
	Amber	On	An abnormal state, such as overload status, has been detected in the switch.
	--	Off	The port has no active network cable connected, or it is not connected to a PoE PD device. Otherwise, the port may have been disabled via the switch user interface.
SFP Ports	Green	On	The port is enabled and has established a link to a connected device, and the connection speed is 1000Mbps.
	Green	Blinking	The port is transmitting/receiving packets, and the connection speed is 1000Mbps.
	Amber	On	The port is enabled, has established a link to the connected device, and the connection speed is 100Mbps.
	Amber	Blinking	The port is transmitting/receiving packets, and the connection speed is 100Mbps.
	--	Off	The port has no active network cable connected, or it has not established a link to a connected device. Otherwise, the port may have been disabled via the switch user interface.

\* With a non-PD device connected to the port: RJ-45 Up LED on, RJ-45 down LED off. With a PD device connected to the port: RJ-45 Up LED on, RJ-45 down LED on. With PD connected on the switch and both the Green LED and Amber LED lit, Green=PoE and Amber=speed.

**Table 5: RM (Ring Master) and RC (Rapid-Chain) LEDs**

LED	RM (Ring Master)	RC (Rapid-Chain)
Off	disable	disable
Green	Ring Master is Enabled	Rapid-Chain (Active path)
Amber	Ring Slave is Enabled	Rapid-Chain (Backup path)
Blink Amber	Error: More than one Master in this ring.	Error: Rapid-Chain Switch did not find the other Rapid-Chain Switch partner (active and backup).

### Front Panel 2-Position DIP Switch

The DIP switches are used for Single Ring and Ring Failover quick settings as described below. See the *Web User Guide* or the *CLI Reference* for more information on Ring configuration and setup.



**Table 6: DIP Switch Descriptions**

RM	RC	R-Ring Settings	Ring Port 1	Ring Port 2	RM (Ring Master) LED	RC (Rapid-Chain) LED
Off	Off	R-Ring Slave	Maximum Even Port Number	Maximum Even Port Number	Lit Amber	Off
ON	Off	R-Ring Master	Maximum Odd Port Number	Maximum Even Port Number	Lit Green	Off
Off	ON	R-Ring Failover	Maximum odd Port Number	Maximum Even Port Number	Off	Lit Green (Active Path) Lit Amber (Backup Path)
ON	ON	R-Ring Settings by Software (default)	--	--	--	--

1. The default DIP switch settings are both ON, meaning that Rings are configurable via the Web, telnet, and Console.

## Rings Support

The switches support several Ring configurations:

1. Multiple Rapid Ring
2. Single Rapid Ring
3. Ring-to-Ring
4. Dual-Ring Configuration
5. Rapid Chain (Rapid Backup)
6. EPS (Ethernet Protection Switching) per ITU-T G.8031.
7. ERPS (Ethernet Ring Protection Switching) per ITU-T G.8032.

The DIP switches are used for Single Ring and Ring Failover quick settings (see DIP switch description above).

See the Web User Guide or the CLI Reference for more information.

Note that Spanning Tree must be disabled for Rapid Ring operation.

EPS and ERPS are standard protocols that can be used between various vendor switches.

Rapid Rings protocols are only for Transition Networks switches that support Rapid Ring protocols.

### Notes:

1. The DIP Switches are only for Single Ring and Ring Failover.
2. DIP Switch settings have higher priority than software configuration.
3. Any Port can be configured as a Ring Connecting port.
4. The DIP switch can only set Single Ring and Rapid-Chain preferences.
5. Multiple Ring, Dual Ring, and Ring-to-Ring can only be set by software.
6. When the DIP Switch is not set to SW Mode, set DIP switch to Priority, By-pass SW.

### RESET Button

By pressing the **RESET** button for a specific amount of time, you can:

**Reset the Switch:** to reboot and get the switch back to the previous configuration settings saved.

**Restore the Switch to Factory Defaults:** to restore the original factory default settings back to the switch.



Use the table below to determine which task is being performed by reading the LED behaviors while pressing the **RESET** button. When the LED behaviors are correctly displayed, release the **RESET** button.

**Table 7: RESET Button Description**

Task to perform	Press RESET for	SYS LED Behavior	Port Status LED Behavior
Reset the Switch	2 ~ 7 seconds	Blinking Green	ALL LEDs are Off.
Restore to Defaults	7 ~ 12 seconds	Blinking Green	ALL LEDs stay lit.

After you release the **RESET** button, wait a few moments for LED activity to stop.

### Front Panel Ground Screw

The front panel grounding screw () can be used for grounding.

Grounding and wire routing help limit the effects of noise due to electromagnetic interference (EMI). Run the ground connection from the ground screws to the grounding surface prior to connecting devices.

**Note:** Both the switch and Power Supply 25104 / 25105 must have their ground terminals connected to earth ground.



**ATTENTION:**

- This case must be earth grounded.
- No DC input may be earth grounded.
- Use Isolated Power Supply.

**ATTENTION**

This case must be earth grounded.  
 No DC input may be earth grounded  
 Use Isolated Power Supply

## 2. Installing the Switch

### Package Contents

Verify that you have received the items below. Contact your sales representative if any item is missing.

Please save the packaging for possible future use.

- One Switch
- One Terminal Block (Euro Block)
- One printed Quick Start Guide
- One DIN Rail mounting bracket and two screws
- One DB-9 to RJ-45 Console Cable
- Power Supply (one or two; optional)



### Unpacking

Unpack and verify the contents in their install location, and continue with one of the mounting procedures below (Desktop, DIN Rail, or Wall mounting).

### Desktop Mounting

1. Make sure the cables can reach the switch.
2. Make sure that the switch and mounting surface are stable.

## DIN Rail Mounting

1. Attach the DIN Rail mounting kit to chassis back panel. Insert screws and tighten with a screwdriver.

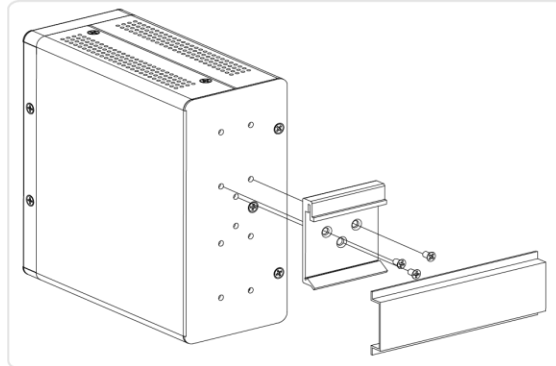

**Figure 2: Attaching DIN Rail Kit to the Switch**

2. Insert the upper lip of the DIN rail into the DIN-rail mounting kit. Press the switch towards the DIN rail until it snaps into place.

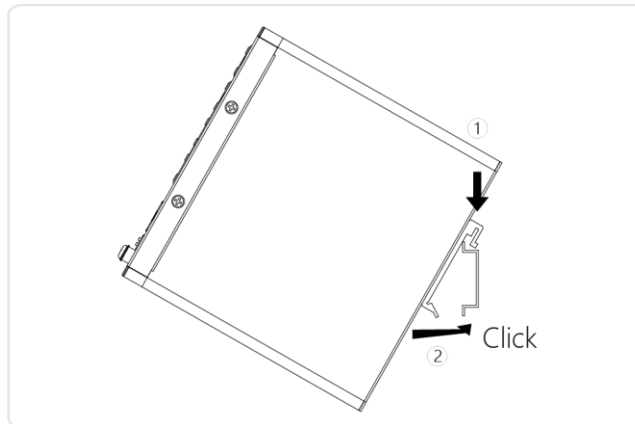

**Figure 3: Insert switch to the DIN Rail**

3. Make sure that the switch is attached securely to DIN Rail.

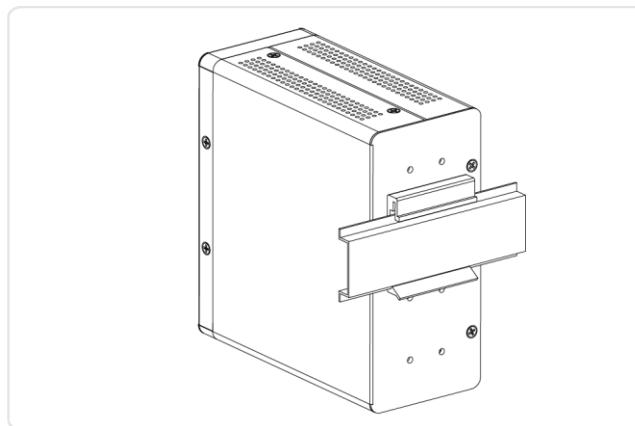
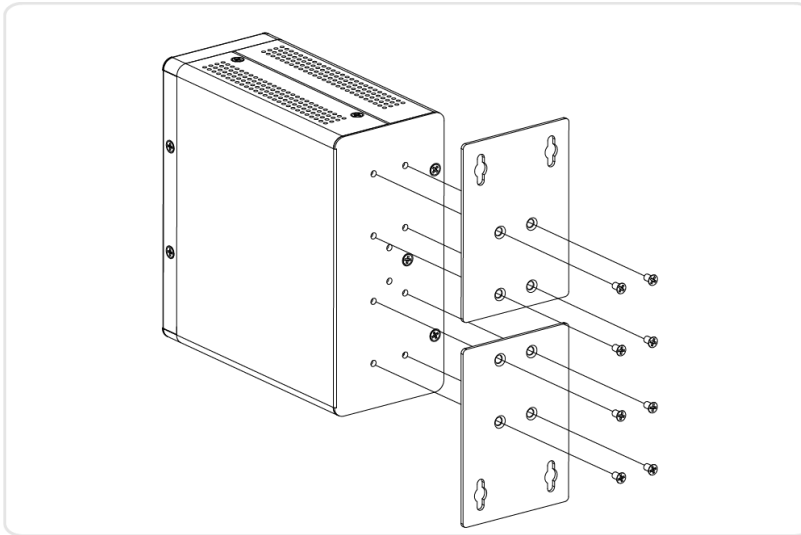

**Figure 4: The switch attached to DIN Rail**

### Wall Mounting (Optional)

See the WMBH-01 manual for more details.

1. Attach the wall mounting plates to rear panel of the chassis. Insert screws and tighten then with a screwdriver to secure the plates.



**Figure 5: Attaching Wall Mounting Plates to the Switch**

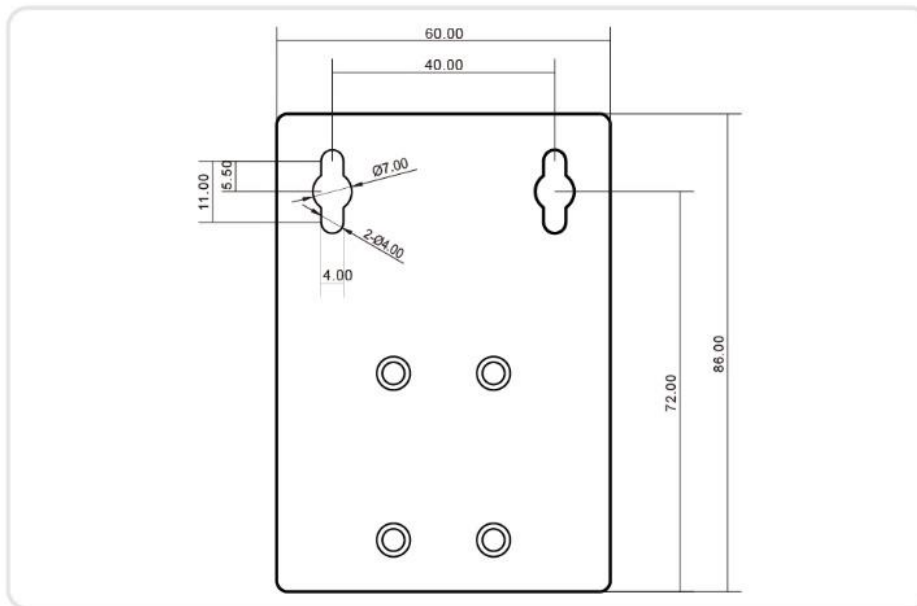

**Figure 6: Wall Mounting Plate Dimensions**

2. Install user-supplied screws on the appropriate location on the wall.
3. Make sure the switch is attached securely to wall.

## Connecting Copper Ports

1. Connect the provided DB-9 to RJ-45 Console Cable to a PC or Terminal.
2. Connect the Ethernet RJ45 Ports to the Ethernet cables/far end devices. Only connect PDs which support power input in 48~56V range to prevent damage to PDs.

## Installing SFP Modules

On the SISPM1040-384-LRT-C, you can install or remove an SFP module from a SFP port without having to power off the switch.

**Note:** Use UL Listed Transceiver SFPs rated 3.3Vdc, Laser Class 1. See the SFP manual for cautions and warnings.

1. Insert the module into the SFP port.
2. Press firmly to ensure that the module seats into the connector.

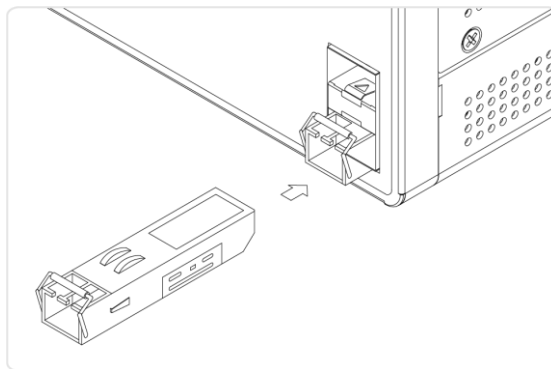
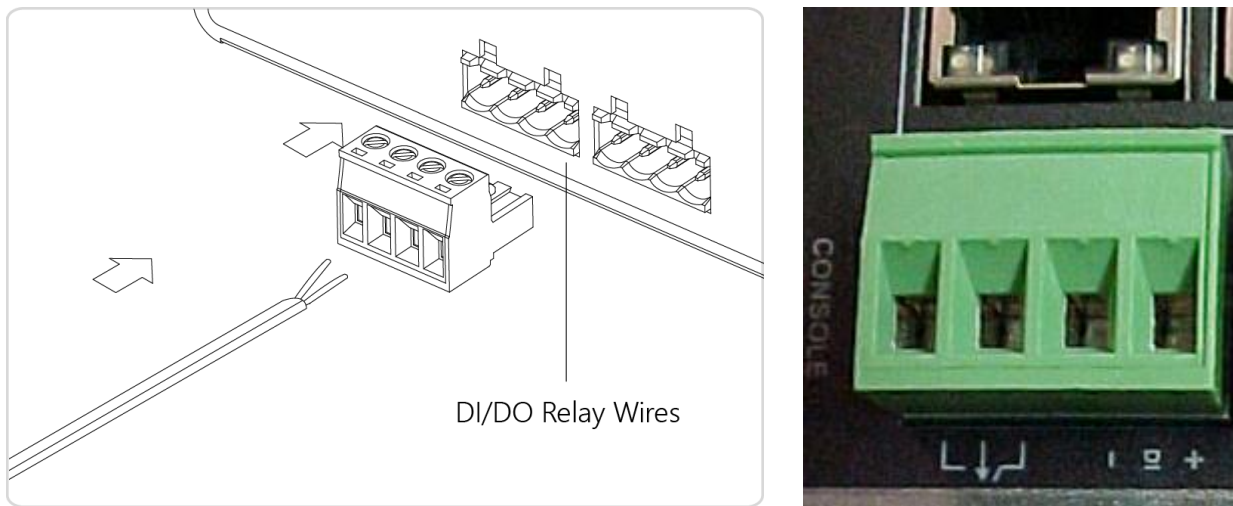

**Figure 7: Installing an SFP Module into an SFP Port**



## Connecting the DI/DO Relay Wires

The lower Euro Block (Terminal Block) provides connection of the optional DI/DO Relay wires.



**Figure 9: Connecting DI/DO Relay Wires**

1. Insert the negative (ground)/positive DI/DO Relay wires into the + and - terminals, respectively.
2. To keep the DI/DO Relay wires from pulling loose, use a small flat-blade screwdriver to tighten the wire-clamp screws on the front of the terminal block connector.
3. Insert the terminal block connector prongs into the terminal block receptor.

### **Notes:**

**Digital Output** (relay): 24VDC/1A.

**Digital Input:** level 0 (Low) -> 0V to 6V, level 1 (High) -> 10V to 24V.

You can configure the normal modes of digital input/output (DI/DO) via the Web UI at the **Home > Configuration > System > Digital I/O** page. See the Web User Guide.

## Digital Input and Digital Output Use Case

The switch supports Digital Input and Digital Output. The Digital Input enables the switch to detect and log external device status (such as door intrusion detector). The Digital Output could be used to tell administrators if the switch port shows link down, link up or power failure. **Note:**

Digital output (relay): 24VDC/1A

Digital input: level 0(Low) -> 0V to 6V, level 1 (High) -> 10V to 24V

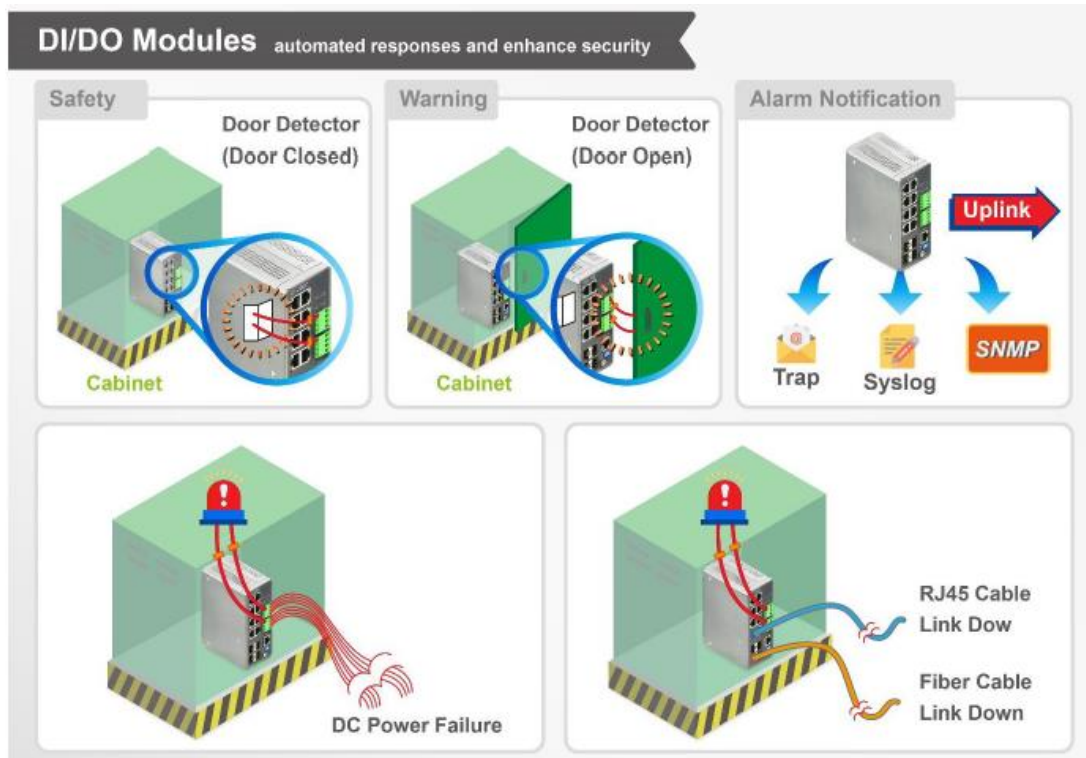

DI: Use for receiving external signal and trigger DO. You may set the voltage input as high or low as DI normal, when DI stays in normal (assume it's set as low), then DO will not response. But the voltage input change to high, DI will show high/ abnormal and at the same time, DO will automatically switch to "abnormal" and send a signal to connected devices, switch will have system recorded.

For example, a water level application:

Setting: low water level: DI normal. High water level: DI abnormal, DIO connected to external alarm notification.

DI will show "normal" when the water level is low. DI will not send signal to DO.

DI will show "abnormal" when sensor senses high water level and will send signal to DO at the same time.

DO will turn to abnormal and send signal to external alarm notification to trigger the alarm LED.

DI is used for connecting external alarm devices and once it is triggered, the switch can send the trap.

An external alarm device (e.g., power supply or IP camera) can activate this input pin.

Level 0 (Low): 0V to 6V

Level 1 (High): 10V to 24V

For DO, it's similar but the switch is the alarm device, when the switch has temperature or voltage alarm, it will trigger the digital output (24V/1A) to the external device such as a contact relay.

See the Web User Guide for DI/DO install information.

### Connecting to DC Power

The upper Euro Block (Terminal Block) provides DC Power Inputs P1 and P2. See [Power Supply Features and Specifications](#) on page 40. **Note:** Both the switch and Power Supply 25105 / 25104 must have their ground terminals connected to earth ground.

**Caution:** Tying the output connection of the DC power supply to earth ground to create an earth referenced voltage power supply will violate the power supply isolation to earth ground requirements of IEEE 802.3af/at/bt. If an earth grounded power supply is utilized, all connected equipment to this power source must then be tied to same local earth ground as the power supply source. Failure to maintain a common earth ground potential for all nodes on the power distribution network can cause equipment damage due to high voltage ground differences between the connected equipment. It is recommended that the power supply connections for PoE networks not be tied to earth ground.

## Power Connection

**ATTENTION:** This case must be earth grounded. No DC input may be earth grounded. Use Isolated Power Supply. Negative DC voltage is not supported.



**Recommended Best Practice:** First, connect the power supply to the switch while powered off. Then connect the power supply to power, otherwise product failure may occur. To properly connect power to the switch, follow these steps:

1. Verify that power is off to the Power source circuit that you are going to attach to the switch PoE DC-input connector. This can be either of the two; power supplies (AC-input or DC-input) or site source DC.
2. As an added precaution, place an appropriate safety flag and lockout device at the source power circuit breaker, or place a piece of adhesive tape over the circuit breaker handle to prevent accidental power restoration while you are working on the circuit.
3. Insert the negative/positive DC wires into the V- and V+ terminals, respectively.
4. To keep the DC wires from pulling loose, use a small flat-blade screwdriver to tighten the wire-clamp screws on the front of the terminal block connector.
5. Insert the terminal block connector prongs into the terminal block receptor.
6. Insert the negative/positive DC wires into the power supply V- and V+ terminals and tighten. See [Power Supply Features and Specifications](#) on page 37.
7. Plug the power supply into an appropriate AC outlet.
8. Check the **SYS** LED. If it is ON, the power connection is correct.

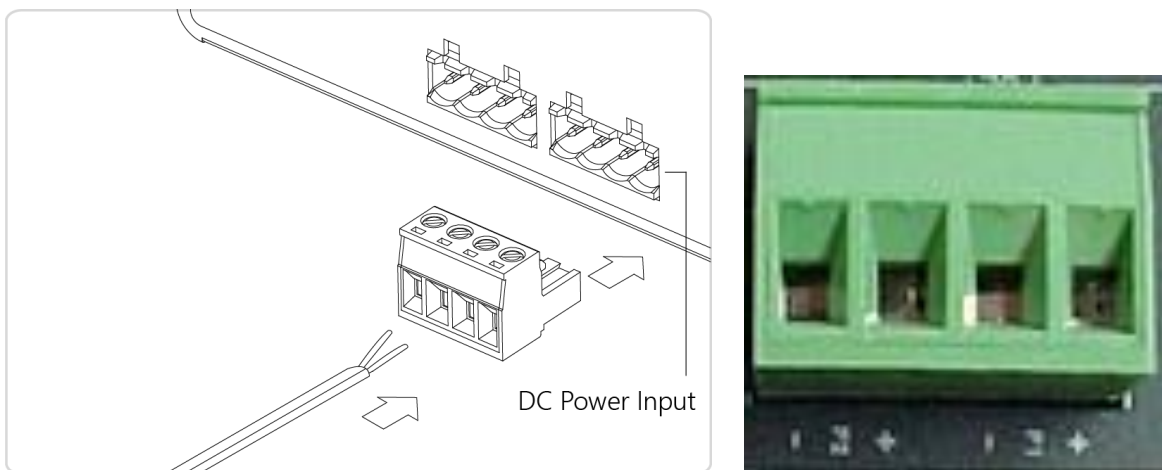

**Figure 8: Connecting DC Power**

## Power Disconnection

To disconnect power from the switch after a successful boot, follow these steps:

1. Turn off power to the power supply that is powering the switch.
2. Make sure the Power LED is off on both the switch and power source.
3. Disconnect the cables.

## 3. Initial Switch Configuration

### Initial Switch Configuration via Web Browser

After powering up the switch for the first time, you can perform the initial switch configuration using a web browser. For managing other switch features, refer to the Web User Guide.

To begin the initial configuration stage, you need to reconfigure your PC's IP address and subnet mask to make sure the PC can communicate with the switch. After changing PC's IP address (for example, 192.168.1.250), then you can access the Web interface of the switch using the switch's default IP address as shown below.

**Note:** You can also skip step 1 to 3, by pressing WinKey+R and type "ncpa.cpl" command to get to step 4 directly.

The initial switch configuration procedure is as follows:

- The factory default IP address is 192.168.1.77
- The factory default Subnet Mask is 255.255.255.0

### Initial Switch Configuration Procedure

The initial switch configuration procedure is as follows:

1. Power up the PC that you will use for the initial configuration. Make sure the PC has the Ethernet RJ45 connector to be connected to the switch via standard Ethernet LAN cable.
2. Reconfigure the PC's IP address and Subnet Mask as below, so that it can communicate with the switch. The method to change the PC's IP address (e.g., for a PC running Windows® 7/8.x/10) is as follows:

**a:** Type "*network and sharing*" into the **Search box** in the **Start Menu**.

**b:** Select **Network and Sharing Center**.

**c:** Click on **Change adapter settings** on the left of the PC screen.

**Note:** You can also skip step a to c, by pressing WinKey+R and type "ncpa.cpl" command to get to step 4 directly.

**d:** Right-click on your local adapter and select **Properties**.

**e:** In the **Local Area Connection Properties** window highlight **Internet Protocol Version 4 (TCP/IPv4)** then click the **Properties** button.

**f:** Select the radio button **Use the following IP address** and enter in the IP for the PC (e.g. any IP address not in use, and in between 192.168.1.2 and 192.168.1.254), Subnet mask (e.g. 255.255.255.0), and Default gateway that corresponds with your network setup. Then enter your Preferred and Alternate DNS server addresses.

**g:** Click **OK** to change the PC's IP address.

3. Power up the switch for its initial configuration, and wait until it has finished its start-up processes.

4. Connect the PC to any port on the switch using a standard Ethernet cable, and check the port LED on the switch to make sure the link status of the PC's is OK.
5. Run your Web browser on the PC, and enter the factory default IP address, to access the switch's Web interface. If your PC is configured correctly, the login page of the switch displays as shown in Figure 10.

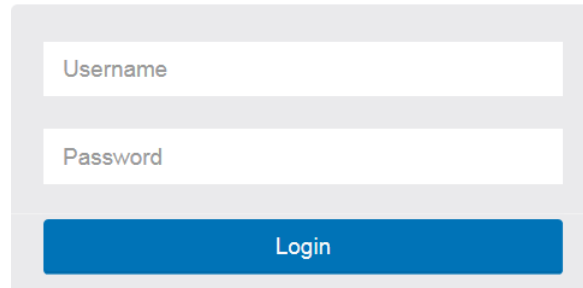

**Figure 10: Web Interface Login page**

If you do not see the above Login page, perform these steps:

- Refresh the web page.
- Check if there is an IP conflict issue.
- Clean browser cookies and temporary Internet files.
- Check your PC settings again and repeat step 2.

6. Enter the factory default Username (**admin**) and Password (**admin**) on the Login page.
7. Click "Login" to log into the switch. The startup page displays; see the *Web User Guide*.

We recommend changing the default credentials before deploying in the network.

**Note:** The factory default Username (**admin**) and the factory default Password (**admin**) are case-sensitive.

### Connect the Switch to a Windows 10 PC

1. Go to your PC's Control Panel > Network and Internet.
2. Click on Network and Sharing Center.
3. Click on Change adapter settings.
4. Select the first available Ethernet connection:
5. Right click on it and go to Properties.
6. On the Networking tab, select Internet Protocol Version 4(TCP/IPv4).
7. Click on the Properties tab.
8. Click the "Use the following IP address" button.
9. Give the same IP subnet as the switch: 192.168.1.5 (your switch.77), Subnet mask: 255.255.255.0.
10. Click OK.
11. Connect your network cable from your PC to your switch.
12. In your web browser address bar type the IP for the switch (192.168.1.77) and hit Enter.
13. Enter the default User name (admin) and Password (admin) all lower case.

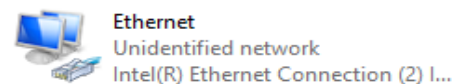

## Initial Switch Configuration via CLI

Use an RJ-45 cable to connect a terminal or PC/terminal emulator to the switch port to access the CLI.

Attach the RJ-45 serial port on the switch front panel to the cable for Telnet/CLI configuration.

Attach the other end of the DB-9 cable to a PC running Telnet or a terminal emulation program such as HyperTerminal or TeraTerm.

After powering up the switch for the first time, you can perform the initial switch configuration using the CLI (Command Line Interface). For managing other switch features, refer to the *CLI Reference* for details.

## 4. Troubleshooting

### Basic Troubleshooting

The switch front panel LEDs provide troubleshooting information. You can also get statistics from the Web UI, the CLI, or from an SNMP workstation.

1. Make sure your switch model supports the feature or function attempted; see chapter [5. Features and Specifications](#) on page [33](#).
2. Verify the install process; see chapter [2. Installing the Switch](#) on page [13](#).
3. Verify the initial switch configuration; see Chapter [3. Initial Switch Configuration](#) on page [21](#).
4. If you have physical access to the switch, check the port LEDs for switch information. See [the LED Descriptions](#) on page [7](#) and [Troubleshooting LED Indications](#) on page [26](#).
5. Examine cables for marginal damage or failure; make sure you have the correct cable for the connection; verify that both sides have link; verify that both devices have power; verify that the interface is not disabled or powered off (manually shut down).
6. Verify that duplex and speed settings are matched between two switches.
7. Troubleshoot connected network devices to pinpoint the problem to the switch.
8. Run the System Diagnostics. See the *Web User Guide* or the *CLI Reference*.
9. If using the CLI, try configuring / testing via the Web UI and vice versa. See the *Web User Guide* or the *CLI Reference*.



## Troubleshooting LED Indications

The following table provides information to troubleshoot problems by taking actions based on the symptom.

Symptom	Possible Cause	Suggested Solutions
SYSTEM LED is Off	The switch is not receiving power.	<ol style="list-style-type: none"> <li>1. Check if correct power cord is connected firmly to the switch and to the DC outlet socket.</li> <li>2. Perform power cycling the switch by unplugging and plugging the power cord back into the switch.</li> <li>3. If the LED is still off, try to plug power cord into a different DC outlet socket to make sure correct DC source is supplied.</li> </ol>
Port Up Status LED is Off	The port is not connected or the connection is not working.	<ol style="list-style-type: none"> <li>1. Check if the cable connector plug is firmly inserted and locked into the port at both the switch and the connected device.</li> <li>2. Make sure the connected device is up and running correctly.</li> <li>3. If the symptom still exists, try a different cable or different port, to identify if it is related to the cable or specific port.</li> <li>4. Check if the port is disabled in the configuration settings via the Web user interface.</li> </ol>
Port Down Status LED is Off	The port is not supplying PoE power	<ol style="list-style-type: none"> <li>1. Check if the cable connector plug is firmly inserted and locked into the port at both the switch and the connected device.</li> <li>2. Make sure the correct Ethernet cables are used.</li> <li>3. If the symptom still exists, try different cable or different port, in order to identify if it is related to the cable or specific port.</li> <li>4. Check if the port is disabled in the configuration settings via the Web user interface.</li> <li>5. Try adjusting the power supply output voltage; see <a href="#">Power Supply Voltage Adjustment</a> on page 43.</li> </ol>

See the LED Summary table below for details.

**LED Summary**

Category	LED	Color	Function
Global	SYS	Green	System status LED: LED Off: All Power is off. Green Lit: Switch FW Boot up is Ready. Green blinking: System is booting.
Global	P1	Green	Power 1 LED: LED Off: Power 1 off. LED Lit: Power 1 on.
Global	P2	Green	Power 2 LED: LED Off: Power 2 off. LED Lit: Power 2 on.
Global	ALM	Green	Alarm LED: LED off: System normal (no alarm). Red lit: Minor alarms. Red blinking: Major alarms (Temperature, Voltage, DC Power 1 or 2 detected, Looping , etc.).
Global	RM	Green/ Amber	Ring Master LED: LED off: disabled (no Alarm). Green lit: Ring Master enabled. Amber lit: Ring Slave enabled. Blinking Amber: A single Ring has more than two Masters.
Global	RC	Green/ Amber	Rapid Chain LED: LED off: Rapid Chain (Active path). Green lit: Rapid Chain (Backup path). Amber blinking: Rapid Chain Switch not found.
TP Ports 1-4	PoE	Green/ Amber	Power over Ethernet LED: LED off: PoE is off. Green lit: PoE is on. Amber lit: PoE abnormal.
TP Ports 1-6	Link/Act/Speed	Green/ Amber	Green lit: device connected at 1000Mbps. Amber lit: device connected at 100Mbps or 10Mbps. LEDs blinking: port is sending or receiving data.
SFP Ports 7-8	Link/Act/Speed	Green/ Amber	Green lit: device connected at 1000Mbps. Amber lit: device connected at 100Mbps. LEDs blinking: port is sending or receiving data.

## PoE Modes and Compliance

### PoE Deployment Environments A and B

IEEE802.3at-2009 defines two deployment environments in section 33.4.1:

**Environment A:** when both PSE and PD are located indoors, inside the same building. In this environment, there has to be electrical isolation between the PoE circuitry and the data circuitry inside a PSE. Multi-port PSE's can all share the same ground isolation. Environment A is therefore an indoor PSE –indoor PD environment (a.k.a. indoor/indoor).

**Environment B:** when the PSE and PD are not located in the same building. In this environment there needs to be electrical isolation between PoE and data, as well as between every port in a multi-port PSE. This isolation between ports requirement de facto determines a completely separate power supply per port, which makes multi-port PSE's for outdoor PD deployment impractical. Environment B is therefore an indoor PSE-outdoor PD (a.k.a. indoor/outdoor) or outdoor PSE-outdoor PD (a.k.a. outdoor/outdoor) environment.

This means only single-port PSE's should normally be used when PD's are deployed outdoors. In summary, the PD-PSE environment is one of these three combinations:

1. PoE Source is indoor, PD is indoor (Env. A)
2. PoE Source is indoor, PD is outdoor (Env. B)
3. PoE Source is outdoor, PD is outdoor (Env. B)

Option 3 is the most challenging environment since both the PD and PSE are installed outdoors.

**Caution:** The switch is an indoor device. If it is to be used with outdoor devices such as outdoor IP cameras or outdoor Wi-Fi APs, then you are strongly suggested to install a surge protector or surge suppressor in order to protect the switch. The switch is compliant with 802.3at in Environment A when using an isolated power supply. For 802.3at Environment B applications, i.e. building to building, copper to copper endpoint connections: 1) use an Ethernet network isolator module (PoE disabled), or 2) use mid-span injector (s), e.g. MIL-L100i, L1000i-at, between this switch's PSE port and link partner PD port.

### Mode A vs. Mode B

Alternative A, also known as Mode A, uses the data pairs of an Ethernet link to deliver power. Data Pairs include pins 1,2 and 3,6. PSEs using Mode A supply a positive voltage to pins 1 and 2. Alternative B, also known as Mode B, uses the spare pairs to deliver power. Spare Pairs include pins 4,5 and 7,8.

### **802.3af/at Standard "compliant" vs "compatible" PDs**

Knowing the difference between PoE "compliant" and "compatible" devices can help avoid interoperability and connectivity issues. Compliant PoE devices and compatible PoE devices are not held to the same 802.3af/at standard:

- 802.3af/at "compliant" PDs fulfill the IEEE strict requirement to support both Mode A and Mode B power modes.
- 802.3af/at "compatible" PDs typically can provide power using only Mode B.

### **Typical PD Power Requirements**

- 1.8 Watts: Transition Networks' M/GE-ISW-SFP-01-PD (Class 1 Powered Device (0.44 Watts - 3.84 Watts)).
- 13W: IP Camera, VoIP Phone, Wireless Access Point, Networked Audio.
- 30W: IP Telephone, WiMAX Access Point, PTZ Camera, Remote Computer Terminal.
- 60W : Door Access System, Video Phone, Thin Client.
- 100W: Digital Signage Display, Point-of-Sale System, LCD TV, Computer Monitor.
- 200W: Larger TV, Larger Display, Larger Monitor, Laptop.

After eliminating basic network factors, ask your PD vendor for the PD's power supply mode and polarities supported and exact power consumption.

### **Calculate PoE Power Budget**

To calculate how many 802.3at devices the unit supports, divide the Total PoE Budget (130 Watts) by 30 Watts.

To calculate the maximum number of 802.3af devices, divide the Total PoE Budget (130 Watts) by 15.4 Watts.

### **VoIP vs SIP**

VoIP (Voice over IP) involves making or receiving phone calls over the Internet or internal networks.

SIP (Session Initiation Protocol) is an application layer protocol used to establish, modify, and terminate multimedia sessions such as VoIP calls. One difference is their scope. VoIP is not a discrete technology; it is a set of technologies used in modern telecom networks. SIP is a signaling protocol used within VoIP technology.

Another difference is that VoIP sends only voice messages, while SIP can carry all media forms (not just voice messages).

### **Mixing POE and Non-POE Devices**

You can mix POE and non-POE devices on the same POE switch (i.e., you can put PCs on the same POE switch as a SIP phone or a VOIP phone). The PSE (your switch) will only send power if requested by the PD.

### Ethernet and PoE Intra-Building Cabling Warnings

1. Ethernet cables are intended for intrabuilding use only. Connecting your TN switch directly to Ethernet cables that run outside the building in which the switch is housed will void the user's warranty and could create a fire or shock hazard.
2. PoE cables are intended for intrabuilding use only. Connecting your TN switch directly to PoE cables that run outside the building in which the switch is housed will void the user's warranty and could create a fire or shock hazard.
3. For outdoor PoE applications, we recommend using Transition Networks' SI-IES-1200-LRT Unmanaged Hardened PoE+ Injector or SI-IES-111D-LRT Unmanaged Hardened PoE+ Injector/Converter. Use of any other PoE injector will void the user's warranty and could create a fire or shock hazard.

### Legacy PD Detection / Capacitor Detection

Legacy PDs refers to powered devices manufactured before the IEEE standard was finalized and do not have the expected PD signature required by the PSE's detection signal. Such PDs usually feature large capacitance as the detection signature that does not completely comply with the 802.3af specs. By enabling this option, the switch will probe for legacy PDs and if a legacy PD is detected, the switch will provide power to the PD.

### Troubleshooting PoE Problems

1. Get as much detail as possible regarding the symptom, including any system messages from the PoE switch. For example, does a PD not power up at all, or does it power up briefly and then power down?
2. Determine if the trouble occurred on initial installation or after the PD had been working normally.
3. If the trouble started after the PD was working, what changed? Were there any hardware or software changes?
4. Verify that the port is not shut down, disabled, or errored.
5. Verify that the Ethernet cable from the PD to the switch port is good. Noncompliant cabling or powered devices can cause a PoE port fault; use only standard-compliant cabling.
6. Verify that the total cable length from the switch front panel to the connected PD is not more than 100 meters. Some of the power from the switch port is dissipated in the cable due to wire resistance, especially on cables as long as 100 meters. Only the remaining power is available to the PD. The 100-meter limit for twisted-pair Ethernet cable assumes **a)** not more than four RJ-45 connection points in the transmission path, **b)** 90 meters of solid-strand Category 5 or 5e, and **c)** 10 meters of flexible multistrand cable (2-to-5 meters of multistrand Category 5 patch cords).
7. Verify that the PSE switch power budget can power the PD. If the switch power budget is depleted, additional PDs will not power-on when connected to a PoE port. Verify that the switch power budget (available PoE) is not depleted before or after the PD is connected. Verify that sufficient power is available for the PD type.

8. Verify if non-powered Ethernet devices can establish an Ethernet link on any port and that PoE devices do not power up on the same port.
9. Review alarms reported previously by system messages.
10. If a working IP Phone or WAP intermittently reloads or disconnects from inline power, verify all electrical connections from the switch to the PD. An unreliable connection results in power interruptions and intermittent PD operation, such as PD disconnects and reloads.
11. Check for changes in the electrical environment at the switch site. What is happening at the PD when the disconnect occurs? Check for error messages reported by the switch at the same time of the disconnect.
12. Verify that an IP Phone is not losing access just before a reload occurs (a network problem, not a PoE problem).
13. Pre-standard and post-standard VoIP phones may use different detection and connect / disconnect methods. Note that PD detection occurs when an Ethernet device is first connected to a PoE port. If a non-PoE device is connected to a PoE port, detection is deactivated. If the non-PoE device is later disconnected and replaced by a PD, the switch may not detect it immediately.
14. Verify that the PD is not causing an overcurrent condition on the port. Specifically: does the VoIP phone initially power on and then disconnect? If so, the problem may be an initial current surge that exceeds a current-limit threshold for the switch port. Some PDs may have excessive “surge in” current when first connected to a PoE port. The switch initially provides power to the port, and then quickly removes power due to a momentary overcurrent condition. The PD starts to power up, but then quickly powers down.
15. Most PoE switches have voltage and current regulators that detect an overcurrent threshold and disconnect power from the line. This prevents excessive current from being delivered by the PoE port, which could possibly result in damage to port-level components.
16. A variety of disturbances on the AC power line (mains) can cause odd PoE problems. The power supplies in various switches and PDs can react uniquely to AC input disturbances. AC disruption problems are usually temporary or one-time occurrences. For example, a specific switch or PD may reboot due to an AC power problem, while other switches or PDs may show a greater immunity to the problem. This is a typical occurrence during lightning storms or AC power maintenance. In a worst-case scenario, a PoE power supply may appear to shut down, with no PoE output voltage to any port. It is possible the switch’s Ethernet functions appear normal, and only the PoE functions are disrupted or degraded, or the switch may power down completely due to the AC disturbance. PDs may exhibit unusual behavior. In such cases, power cycle the switch (unplug the switch, wait at least three seconds, then plug it back in. This will ensure a total system reset that should restore normal operation.

Check if related features (LLDP mode, CDP mode) are enabled. See the Transition Networks [PoE Brochure](#) for more information.

## Related Manuals

These manuals give specific information on how to use the switch:

- Quick Start Guide, SISPM1040-384-LRT-C & SISPM1040-362-LRT, 33726
- Web User Guide, SISPM1040-384-LRT-C & SISPM1040-362-LRT, 33728
- CLI Reference, SISPM1040-384-LRT-C & SISPM1040-362-LRT, 33729
- API User Guide for SISPM1040-384-LRT-C and SISPM1040-362-LRT, 33824
- Release Notes (version specific)

To access the manuals, firmware, datasheet or other documentation for your product, enter your model number in the “Search” box at our website at <https://www.transition.com>. For Transition Networks Drivers, Firmware, Manual, etc. go to the [Product Support](#) webpage (no logon required). For Transition Networks Application Notes, Brochures, Data Sheets, Specifications, etc. go to the [Support Library](#) (no registration required).

## Device Label and Packaging Label

In addition to the device CLI and Web GUI, you can find device information on the device Serial Label (left) and box Serial Label (right).

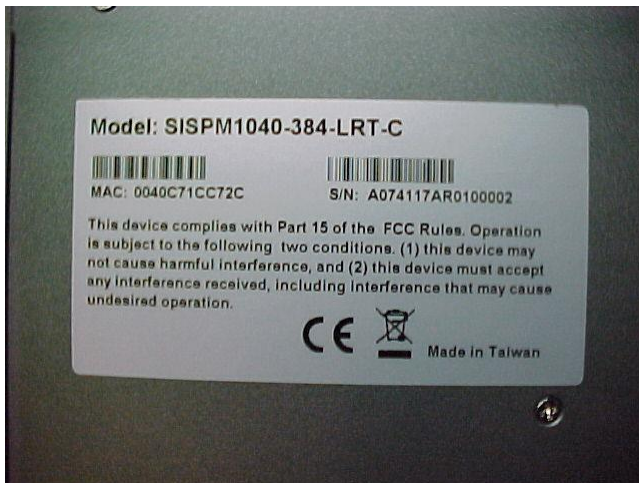

**Serial Label on Unit (left)**



**Serial Label on Box (right)**

### Record Device and System Information

After performing the troubleshooting steps, and before calling or emailing Technical Support, please record as much information as possible in order to help the Transition Networks Tech Support Specialist.

1. Select the **Configuration > System > Information** menu path. From the CLI, use the **show** commands needed to gather the information below or as requested by the TN Support Specialist.

2. Model Name: \_\_\_\_\_ Serial Number: \_\_\_\_\_

Firmware Version: \_\_\_\_\_ Power Supply: \_\_\_\_\_

3. Record the LED Status: \_\_\_\_\_  
\_\_\_\_\_  
\_\_\_\_\_

4. Provide additional information to your Tech Support Specialist. See the "Troubleshooting" section above.

Your Transition Networks service contract number: \_\_\_\_\_

Describe the failure: \_\_\_\_\_  
\_\_\_\_\_  
\_\_\_\_\_

Describe any action(s) already taken to resolve the problem (e.g., changing mode, rebooting, etc.): \_\_\_\_\_  
\_\_\_\_\_  
\_\_\_\_\_

The serial and revision numbers of all involved Transition Networks products in the network: \_\_\_\_\_  
\_\_\_\_\_  
\_\_\_\_\_

Describe your network environment (layout, cable type, etc.): \_\_\_\_\_  
\_\_\_\_\_  
\_\_\_\_\_

Network load and frame size at the time of trouble (if known): \_\_\_\_\_

The device history (i.e., have you returned the device before, is this a recurring problem, etc.):  
\_\_\_\_\_  
\_\_\_\_\_  
\_\_\_\_\_

Any previous Return Material Authorization (RMA) numbers: \_\_\_\_\_



## 5. Features and Specifications

### Key Features

**SISPM1040-362-LRT:** Managed Hardened PoE+ Switch; provides (4) 10/100/1000Base-T PoE+ ports + (2) 10/100/1000Base-T ports + (2) 100/1000Base-X SFP slots and one RJ45 Console port.

**SISPM1040-384-LRT-C:** Managed Hardened PoE+ Switch; provides (8) 10/100/1000Base-T PoE+ RJ45 ports + (4) 100/1000Base-X SFP slots and one RJ45 Console port.

Feature	SISPM1040-362-LRT	SISPM1040-384-LRT-C
Rapid Ring (R-Ring)	X	X
Built in Device Management System (DMS)	X	X
DHCP Server	X	X
IEEE 802.3az Energy Efficient Ethernet standard for green Ethernet application	X	X
IEEE 802.3af/at Power over Ethernet	X	X
IEEE 802.3af/at Power over Ethernet	X	X
IPv4/IPv6 L3 static route	X	X
ITU-T G.8031 Ethernet Linear Protection Switching (EPS)	X	X
ITU-T G.8032 Ethernet Ring Protection Switching (ERPS)	X	X
IEEE 1588v2 PTP	X	X
IEEE 802.3ah OAM	X	X
IEEE 802.1ag CFM (ITU-T Y.1731 Performance Monitoring)	X	X
Media Redundancy Protocol (MRP)	X	X
SCP Server and SFTP Client Commands	X	
<b>Port Configuration</b>		
Total Ports	8	12
RJ45 (10M/100M/1G) ports	6	8
Uplink ports	2 SFPs	4 SFPs
Console port	One RJ45	One RJ45
Available PoE Power	120W	240W
Ring Management	DIP switch	DIP switch
DI/DO	1/1	1/1

SISPM1040-362-LRT FW v7.20.0034 added SFTP commands in CLI and DHCP Option 3.

Feature	SISPM1040-362-LRT	SISPM1040-384-LRT-C
<b>Hardware Performance</b>		
Forwarding Capacity (Mpps)	11.904	17.586
Switching Capacity (Gbps)	16	24
Mac Table (K)	8	8
Jumbo Frames (Bytes)	9216	9216
<b>Environmental Range</b>	<b>SISPM1040-362-LRT</b>	<b>SISPM1040-384-LRT-C</b>
Operating Temperature	-40 to 167F -40 to 75C	-40 to 167F -40 to 75C
Storage Temperature	-40 to 185F -40 to 85C	-40 to 185F -40 to 85C
Operating Humidity	5% to 95% non-condensing	5% to 95% non-condensing
Altitude	< 10,000 ft < 3000 m	< 10,000 ft < 3000 m
<b>Dimensions, Weight, Power</b>	<b>SISPM1040-362-LRT</b>	<b>SISPM1040-384-LRT-C</b>
Dimensions (WxHxD)	62x135x130 mm 2.4x5.3x5.1 in	62x135x130 mm 2.4x5.3x5.1 in
Weight	2 lbs. [0.9 kg]	2.2 lbs. [1 kg]
Power Consumption Without PoE	8.2 Watts	11.1 Watts
Power Input	48 - 57VDC; redundant inputs with reverse polarity protection and overload current protection	48 - 57VDC; redundant inputs
Ingress Protection	IP30	IP30

## Software Features

SISPM1040-384-LRT-C and SISPM1040-362-LRT	
<b>Ring Management</b>	
Rapid Ring	Enables self-recover time in less than 20ms.
ITU-T G.8031	Supports ITU-T G.8031 Ethernet Linear Protection Switching (EPS).
ITU-T G.8032	Supports ITU-T G.8032 Ethernet Ring Protection Switching (ERPS).
<b>Device Management System (DMS)</b>	
Graphical Monitoring	Topology view: Supports intuitive way to configure and manage switches and devices with visual relations. Floor view: Easily drag and drop PoE devices and help you to build smart workforces. Map view: Enhance efficiency to drag and drop devices and monitor surroundings on Google Maps.
Find my Switch	Search for and manage a switch quickly.
Traffic Monitoring	Displays visual chart of network traffic of all devices and monitor every port at any time from switches.
Troubleshooting	Network diagnostic between master switch and devices. Supports protection mechanisms, such as rate-limiting to protect your devices from brute-force downloading. Supports performance management and link management via IEEE 802.3ah and IEEE 802.1ag (Y.1731).
<b>Ethernet OAM</b>	
IEEE 802.3ah OAM	Supports Operations, Administration & Management
IEEE 802.1ag & ITU-T Y.1731 Flow OAM	Supports IEEE 802.1ag Ethernet CFM (Connectivity Fault Management)
	Supports ITU-T Y.1731 Performance Monitoring
<b>Layer 2 Switching</b>	
Spanning Tree Protocol (STP)	Standard Spanning Tree 802.1d Rapid Spanning Tree (RSTP) 802.1w. Multiple Spanning Tree (MSTP) 802.1s.
Trunking	Link Aggregation Control Protocol (LACP) IEEE 802.3ad. Up to 6 groups and up to 4 ports per group.
VLAN	Port-based VLAN 802.1Q tag-based VLAN MAC-based VLAN Management VLAN Private VLAN Edge (PVE) Q-in-Q (double tag) VLAN Voice VLAN GARP VLAN Registration Protocol (GVRP)
DHCP Relay	Relay of DHCP traffic to DHCP server in different VLAN. Works with DHCP Option 82.
IGMP v1/v2/v3 Snooping	IGMP limits bandwidth-intensive multicast traffic to only the requesters. Supports 1024 multicast groups.

<b>SISPM1040-384-LRT-C and SISPM1040-362-LRT</b>	
IGMP Querier	Used to support a Layer 2 multicast domain of snooping switches in the absence of a multicast router.
IGMP Proxy	IGMP snooping with proxy reporting or report suppression actively filters IGMP packets in order to reduce load on the multicast router.
MLD v1/v2 Snooping	Delivers IPv6 multicast packets only to the required receivers.
Multicast VLAN Registration (MVR)	Uses a dedicated manually configured VLAN, called the multicast VLAN, to forward multicast traffic over Layer 2 network in conjunction with IGMP snooping.
Layer 3 Switching	
IPv4 Static Routing	IPv4 Unicast: Static routing
IPv6 Static Routing	IPv6 Unicast: Static routing
<b>Security</b>	
Secure Shell (SSH)	SSH secures Telnet traffic in or out of the switch, SSH v1 and v2 are supported.
Secure Sockets Layer (SSL)	SSL encrypts the http traffic, allowing advanced secure access to the browser-based management GUI in the switch.
IEEE 802.1X	IEEE802.1X: RADIUS authentication, authorization and accounting, MD5 hash, guest VLAN, single/multiple host mode and single/multiple sessions. Supports IGMP-RADIUS based 802.1X. Dynamic VLAN assignment.
Layer 2 Isolation Private VLAN Edge	PVE (AKA protected ports) provides L2 isolation between clients in the same VLAN. Supports multiple uplinks.
Port Security	Locks MAC addresses to ports, and limits the number of learned MAC address.
IP Source Guard	Prevents illegal IP address from accessing to specific port in the switch.
RADIUS/ TACACS+	Supports RADIUS and TACACS+ authentication. Switch as a client.
Storm Control	Prevents traffic on a LAN from being disrupted by a broadcast, multicast, or unicast storm on a port.
DHCP Snooping	Acts as a firewall between untrusted hosts and trusted DHCP servers.
ACLs	Supports up to 256 entries. Drop or rate limitation based on: Source and destination MAC, VLAN ID or IP address, protocol, port. Differentiated services code point (DSCP) / IP precedence. TCP/ UDP source and destination ports. 802.1p priority. Ethernet type. Internet Control Message Protocol (ICMP) packets. TCP flag.
Loop Protection	Prevents unknown unicast, broadcast and multicast loops in Layer 2 switching configurations.

<b>Quality of Service</b>	
Hardware Queue	Supports 8 hardware queues
Scheduling	Strict priority and weighted round-robin (WRR). Queue assignment based on DSCP and class of service.
Classification	Port based. 802.1p VLAN priority based. IPv4/IPv6 precedence / DSCP based. Differentiated Services (DiffServ). Classification and re-marking ACLs.
Rate Limiting	Ingress policer. Egress shaping and rate control. Per port.
<b>Management</b>	
HW Monitoring	Temperature Detection and Alarm
HW Watchdog	Supported to resume operation from CPU hang up
IEEE 1588v2 PTP	Support IEEE 1588 v2 PTP (Precision Time Protocol)
DHCP Server	Support DHCP server to assign IP to DHCP clients.
Remote Monitoring (RMON)	Embedded RMON agent supports RMON groups 1,2,3,9 (history, statistics, alarms, and events) for enhanced traffic management, monitoring and analysis.
Port Mirroring	Traffic on a port can be mirrored to another port for analysis with a network analyzer or RMON probe. Up to N-1 (N is Switch's Ports) ports can be mirrored to single destination port. A single session is supported.
UPnP	The Universal Plug and Play feature enables device-to-device interoperability by promoting Universal Plug and Play.
s-Flow	Industry standard for monitoring high speed switched networks. It gives complete visibility into the use of networks enabling performance optimization, accounting/billing for usage, and defense against security threats.
LLDP (IEEE 802.1ab)	Used by network devices for advertising their identities, capabilities, and neighbors on an IEEE 802ab local area network. Supports LLDP-MED extensions.
Web GUI Interface	Built-in switch configuration utility for browser-based device configuration.
CLI	Lets you configure/manage switches in command line modes.
Dual Image	Independent primary and secondary images for backup while upgrading.
SNMP	SNMP version1, 2c, and 3 with support for traps, and SNMP version 3 user-based security model (USM).
Firmware Upgrade	Web browser upgrade (HTTP/ HTTPS) and TFTP. Upgrade via Console port as well.

NTP	Network Time Protocol for clock synchronization between computer systems over packet-switched.
Other Management	HTTP/HTTPS; SSH DHCP Client / DHCPv6 Client Cable Diagnostics, Ping, Syslog IPv6 Management
<b>Power over Ethernet (PoE)</b>	
Port Configuration	Supports per port PoE configuration function.
PoE Scheduling	Supports per port PoE scheduling to turn on/off the PoE devices (PDs).
Auto Power Reset (APR)	Checks the link status of PDs. Reboots PDs if there are no responses.
Power Delay	Switch provides power to the PDs based on delay time when PoE switch boots up, in order to protect switch from misuse of the PDs.

**MTBF Specifications**

#	MTBF
<b>SISPM1040-362-LRT</b>	Environment: GB, GC – Ground Benign, Controlled. Temp: 75.00 deg. C. MTBF: 100,874 hours.
	Environment: GB, GC – Ground Benign, Controlled. Temp: 25.00 deg. C. MTBF: 527,730 hours.
<b>SISPM1040-384-LRT-C</b>	Environment: GB, GC – Ground Benign, Controlled. Temp: 75.00 deg. C. MTBF: 92,110 hours.
	Environment: GB, GC – Ground Benign, Controlled. Temp: 25.00 deg. C. MTBF: 476,206 hours.

**Shared Features**

Voltage and Frequency	Primary Power Supply - DC Input Voltage
<b>SISPM1040-384-LRT-C and SISPM1040-362-LRT</b>	
DC Nominal	54 VDC dual inputs
DC Operating Range	48 to 57 VDC
PoE	Requires >48 VDC for PoE IEEE 802.3af (Max. 15.4W output) Requires >54 VDC for PoE+ IEEE 802.3at (Max. 30W output)
<b>PoE Power Capacity</b>	
<b>SISPM1040-362-LRT</b>	
Available PoE Power	120W
Number of Ports that support PoE (15.4W), PoE+ (30W).	Each of ports 1 - 4 support PoE/PoE+ within available PoE.
<b>SISPM1040-384-LRT-C</b>	
Available PoE Power	240W
Number of Ports That Support PoE (15.4W), PoE+ (30W)	Each of ports 1 - 8 support PoE/PoE+ within available PoE Power.

## Shared Certifications and Compliance

EMI	CE, FCC Part 15
EMS	EN61000-4-2, EN61000-4-3, EN-61000-4-4, EN61000- 4-5, EN61000-4-6, EN61000-4-8
Free fall	IEC60068-2-32
Shock	IEC60068-2-27
Vibration	IEC60068-2-6
Safety	IEC62368-1/EN62368-1
Hazardous Location	UL Class 1/Div 2
Railway	EN50155 Compliant, EN50121-4 Compliant
Marine	DNV Compliant
Transportation	NEMA TS-2
Substation	IEC61850-3 Compliant, IEEE1613 Compliant

## Cable Specifications

You may use unshielded twisted-pair (UTP) for RJ-45 connections:

- ❑ Category 3 or better for 10 Mbps connections,
- ❑ Category 5 or better for 100 Mbps connections, or
- ❑ Category 5, 5e, or 6 for 1000 Mbps connections.

For fiber optic connections, you may use:

- ❑ 50/125 or 62.5/125 micron multimode fiber, or
- ❑ 9/125 micron single-mode fiber.

## Power Supply Features and Specifications

The Industrial Power Supplies (25104 and 25105) are optional accessories (sold separately).

- ❑ 25104 Input: 85-264 VAC, 124-370 VDC. Output: 48~55 VDC, 5.0A, 240 Watts.
- ❑ 25105 Input: 85-264 VAC, 124-370 VDC Output: 48~55 VDC, 2.5A, 120 Watts.

**Caution:** Tying the output connection of the DC power supply to earth ground to create an earth referenced voltage power supply will violate the power supply isolation to earth ground requirements of IEEE 802.3af/at/bt. If an earth grounded power supply is utilized, all connected equipment to this power source must then be tied to same local earth ground as the power supply source. Failure to maintain a common earth ground potential for all nodes on the power distribution network can cause equipment damage due to high voltage ground differences between the connected equipment. It is recommended that the power supply connections for PoE networks not be tied to earth ground.



## Industrial Power Supply 25105

**Note:** Both the switch and Power Supply 25105 must have their ground terminals connected to earth ground.

### Output

Output Voltage	48VDC
Current Rating	2.5A
Power Rating	120 Watts
Ripple & Noise Max	120mVp-p
Voltage Range	48~55VDC
Voltage Tolerance	±1.0%
Line Regulation	±0.5%
Load Regulation	±1.0%
Setup, Rise Time	1500ms, 60ms
Hold Up Time	20ms

### Input

Voltage Range	Switch Selectable 88~264VAC 124~370VDC
Frequency Range	47~63Hz
Efficiency	90.5%
AC Current (Typical)	1.4A@115VAC 0.7A@230VAC
Inrush Current (Cold)	35A@115VAC 70A@230VAC Leakage Current <1.0mA@240VAC

### Protection

Overload	110~150%
Overvoltage	56~65V
Over Temperature	95°C±5°C

**Environment** Oper. Temp -25°C~+70°C. Stor. Temp -40°C~+85°C. Humidity: 20~95% non-condensing.

**Features** 91% High Efficiency. 150% Peak Load. Protected against: Short Circuit, Overload, Over Voltage, Overheating. Convection air cooling. DIN rail mountable (S35/7.5 or TS35/15). RoHS compliant. MTBF 298.9 Khrs.

Dimensions (mm): 40W, 125.2H, 113.5D. Weight .67Kg.

### Standards

Safety: UL508, TUV EN60950-1. Vibration: IEC60068-2-6. EMC Emission: EN55011, EN55022, CISPR22 Class B, EN61000-3-2, |EN61000-3-3. EMC Immunity: EN61000-4-2, EN61000-4-3, EN61000-4-4, EN61000-4-5, EN61000-4-6, EN61000-4-8, EN61000-4-11, EN55024, EN61000-6-2, EN50082-2, EN61204-3, SEMI F47, GL Approved.

**+V ADJ:** access to small Phillips screw; turn clockwise to increase voltage. Adjustable, 48-55V.

**DC OK LED:** lights to indicate a DC OK condition.



## Industrial Power Supply 25104

**Note:** Both the switch and Power Supply 25104 must have their ground terminals connected to earth ground.

### Output

Output Voltage	48VDC
Current Rating	5A
Power Rating	240 Watts
Ripple & Noise Max	120mVp-p
Voltage Range	48~55VDC
Voltage Tolerance	±1.0%
Line Regulation	±0.5%
Load Regulation	±1.0%
Setup, Rise Time	300ms, 60ms
Hold Up Time	20ms

### Input

Voltage Range	Switch Selectable. 88~132VAC. 124~370VDC
Frequency Range	47~63Hz
Efficiency	94%
AC Current (Typical)	2.6A@115VAC. 1.3A@230VAC
Inrush Current (Cold)	33A@115VAC. 65A@230VAC

**Protection** Overload 105~160%. Overvoltage 56~65V.

**Environment** Operating Temp. -25°C~+70°C. Storage Temp. -40°C~+85°C.

Operating Humidity 20~95% non-condensing

**Features** 94% High Efficiency. 150% Peak Load. Protected against: Short Circuit, Overload, Over Voltage, Overheating. Convection air cooling. DIN rail mountable (S35/7.5 or TS35/15). RoHS compliant. MTBF 169.3 Khrs. Dimensions (mm): 63W, 125.2H, 113.5D. Weight 1.03Kg.

**Standards** Safety: UL508, TUV EN60950-1. Vibration: IEC60068-2-6. EMC Emission: EN55022, CISPR22 Class B, EN61000-3-2, |EN61000-3-3. EMC Immunity: EN61000-4-2, EN61000-4-3, EN61000-4-4, EN61000-4-5, EN61000-4-6, EN61000-4-8, EN61000-4-11, EN55024, EN61000-6-2, EN50082-2, EN61204-3, SEMI F47, GL Approved.

Mean Well SDR-240-48. **INPUT:** 100-240VAC 2.6A 50/60 Hz. **OUTPUT:** 48V - 5A. "Use copper wire only". "Maximum surrounding air temperature: 60°C". "Instructions for installation in a pollution degree 2 environment".



**Terminal Torque:** 7 Lb-in (DC connections at top of PS). **Terminal Torque:** 4.4 Lb-in (AC connections at bottom of PS). **+V ADJ:** access to small Phillips screw; turn clockwise to increase voltage. Adjustable, 48-55V. **DC OK LED:** lights to indicate a DC OK condition.

**Power Supply Built-in DC OK Relay Contact**

The power supply’s **DC OK** relay contact is provided below.

Contact Closed	PSU turns on / DC OK.
Contact Open	PSU turns off / DC Fail.
Contact Ratings (max.)	30V/1A resistive load.

**Power Supply Terminal Block Pin Number Assignments (TB1)**

The power supply’s **TB1** pinout is provided below.

Pin Number	Assignment
1	FG 
2	AC/N
3	AC/L

**Power Supply Terminal Block Pin Number Assignments (TB2)**

The power supply’s **TB2** pinout is provided below.

Pin Number	Assignment
1,2	Relay Contact
3,4	DC Output +V
5,6	DC Output -V

**Power Supply Voltage Adjustment**

The voltage input range for this switch is 48 to 57 VDC. The power supply used must be an isolated power supply to maintain the product warranty. It may be necessary to adjust the voltage range on the external power supply in order to provide PoE+ output through a long run of cable. Adjust the input voltage by turning the **+V** adjustment screw on the front of the power supply clockwise to increase the voltage to be within the required range.

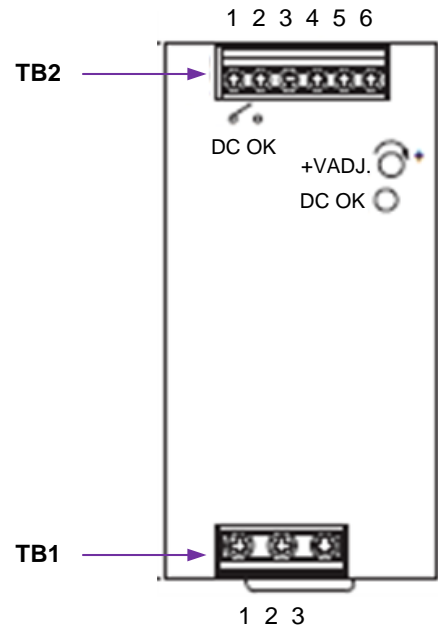

Power Supply Dimensions- 25104 (SDR-240-48)

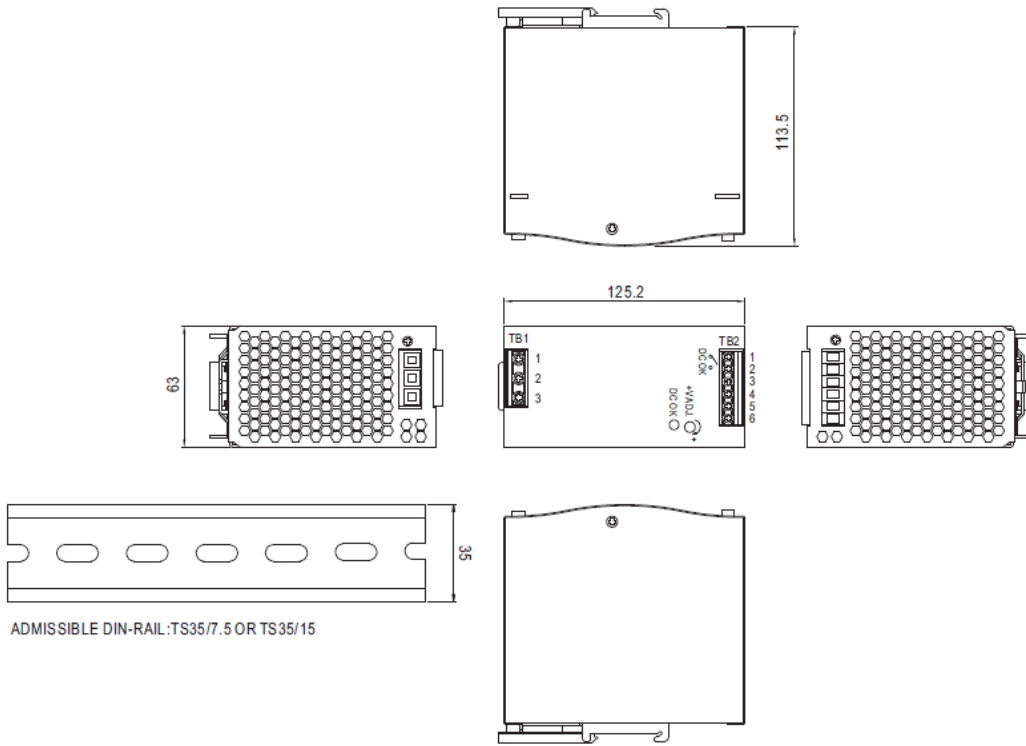

Dimensions (in mm)- 25104 (SDR-240-48)

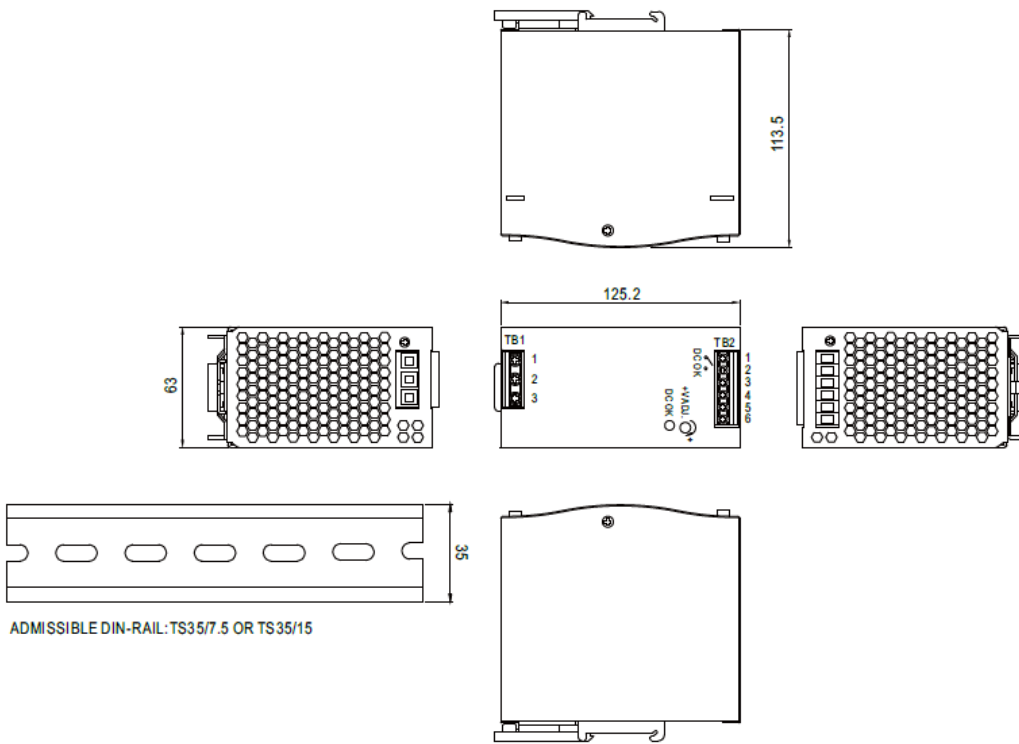

## 6. Regulatory and Safety Information

### Compliance and Safety Statements

FCC-CLASS A: This equipment has been tested and found to comply with the limits for a Class A computing device pursuant to Subpart J of part 15 of FCC Rules, which are designed to provide reasonable protection against such interference when operated in a commercial environment. This equipment generates, uses, and can radiate radio frequency energy and, if not installed and used in accordance with the instruction manual, may cause harmful interference to radio communications. Operation of this equipment in a residential area is likely to cause harmful interference in which case the user will be required to correct the interference at his own expense. You are cautioned that changes or modifications not expressly approved by the party responsible for compliance could void your authority to operate the equipment.

CE MARK DECLARATION OF CONFORMANCE FOR EMI AND SAFETY (EEC): This equipment has been tested and found to comply with the protection requirements of European Emission Standard EN55022/EN61000-3 and the Generic European Immunity Standard EN55024.

### Declaration of Conformity

<b>Declaration of Conformity</b>		
<u>Transition Networks, Inc.</u> Manufacture's Name		
<u>10900 Red Circle Drive, Minnetonka, Minnesota 55343 U.S.A.</u> Manufacture's Address		
<i>Declares that the products:</i>		
<b>SISPM1040-362-LRT, SISPM1040-384-LRT-C</b>		
<i>Conform to the following Product Regulations:</i>		
47 CFR FCC Rules and Regulations Part 15 Subpart B, Class B Digital Device, ISES ICES-003 Issue 6, Class A EN 55032-2012/AC:2013, Class A EN 61000-3-2:2014, EN 61000-3-3:2013 and EN 55024:2010 (IEC 61000-4-2 Edition 2.0 2008-12, IEC 61000-4-3 Edition 3.2 2010-04, IEC 61000-4-4 Edition 3.0 2012-04, IEC 61000-4-5 Edition 2.0 2005-11, IEC 61000-4-6 Edition 4.0 2013-10, IEC 61000-4-8 Edition 2.0 2009-09, IEC 61000-4-11 Edition 2.0 2004-03), IEC62368-1/EN62368-1 and Australian Standard AS/NZS CISPR 32:2013 Class A		
With the technical construction on file at the above address, this product carries the		
<b>CE Mark</b>		
I, the undersigned, hereby declare that the equipment specified above conforms to the above Directive(s) and Standards(s).		
<u>Minnetonka, Minnesota</u> Place	<u>June 22, 2017</u> Date	<u>Stephen Anderson</u> Signature
<u>Stephen Anderson</u> Full Name		<u>Vice President of Engineering</u> Position
		28141B

### Compliance

EMI: CE, FCC Part 15, EN61000-4-2, EN61000-4-3, EN-61000-4-4, EN61000-4-5, EN61000-4-6, EN61000-4-8, EC60068-2-32 (Free fall), IEC60068-2-27 (Shock), IEC60068-2-6 (Vibration), NEMA TS-2.

Safety: IEC62368-1/EN62368-1, UL Class 1/Div 2

Compliant: EN50155, EN50121-4, DNV, IEC61850-3, IEEE1613.

## High Risk Activities Disclaimer

Components, units, or third-party products used in the product described herein are NOT fault-tolerant and are NOT designed, manufactured, or intended for use as on-line control equipment in the following hazardous environments requiring fail-safe controls: the operation of Nuclear Facilities, Aircraft Navigation or Aircraft Communication Systems, Air Traffic Control, Life Support, or Weapons Systems ("High Risk Activities"). Transition Networks and its supplier(s) specifically disclaim any expressed or implied warranty of fitness for such High Risk Activities.

## Cautions and Warnings

### Definitions

**Cautions** indicate that there is the possibility of poor equipment performance or potential damage to the equipment. **Warnings** indicate that there is the possibility of injury to person.

Cautions and Warnings appear here and may appear throughout this manual where appropriate. Failure to read and understand the information identified by this symbol could result in poor equipment performance, damage to the equipment, or injury to persons.

### Cautions

While installing or servicing the power module, wear a grounding device and observe all electrostatic discharge precautions. Failure to observe this caution could result in damage to, or failure of the power module.

### Warnings

**Warning:** Do not connect the power module to an external power source before installing it into the chassis. Failure to observe this warning could result in an electrical shock, even death.

**WARNING:** The power module has a provision for grounding. Equipment grounding is vital to ensure safe operation. The installer must ensure that the power module is properly grounded during and after installation. Failure to observe this warning could result in an electric shock, even death.

**WARNING:** A readily accessible, suitable National Electrical Code (NEC) or local electrical code approved disconnect device and branch-circuit protector must be part of the building's installed wiring to accommodate permanently connected equipment. Failure to observe this warning could result in an electric shock, even death.

**WARNING:** Turn the external power source OFF and ensure that the power module is disconnected from the external power source before performing any maintenance. Failure to observe this warning could result in an electrical shock, even death.

**WARNING:** Ensure that the disconnect device for the external power source is OPEN (*turned OFF*) before disconnecting or connecting the power leads to the power module. Failure to observe this warning could result in an electric shock, even death.

**WARNING:** This case must be earth grounded. No DC input may be earth grounded. Use Isolated Power Supply.

See Electrical Safety Warnings below for Electrical Safety Warnings translated into multiple languages.

## Electrical Safety Warnings

### Electrical Safety

IMPORTANT: This equipment must be installed in accordance with safety precautions.

**Elektrische Sicherheit**

WICHTIG: Für die Installation dieses Gerätes ist die Einhaltung von Sicherheitsvorkehrungen erforderlich.

**Elektrisk sikkerhed**

VIGTIGT: Dette udstyr skal installeres i overensstemmelse med sikkerhedsadvarslerne.

**Elektrische veiligheid**

BELANGRIJK: Dit apparaat moet in overeenstemming met de veiligheidsvoorschriften worden geïnstalleerd.

**Sécurité électrique**

IMPORTANT: Cet équipement doit être utilisé conformément aux instructions de sécurité.

**Sähköturvallisuus**

TÄRKEÄÄ: Tämä laite on asennettava turvaohjeiden mukaisesti.

**Sicurezza elettrica**

IMPORTANTE: questa apparecchiatura deve essere installata rispettando le norme di sicurezza.

**Elektrisk sikkerhet**

VIKTIG: Dette utstyret skal installeres i samsvar med sikkerhetsregler.

**Segurança eléctrica**

IMPORTANTE: Este equipamento tem que ser instalado segundo as medidas de precaução de segurança.

**Seguridad eléctrica**

IMPORTANTE: La instalación de este equipo deberá llevarse a cabo cumpliendo con las precauciones de seguridad.

**Elsäkerhet**

OBS! Alla nödvändiga försiktighetsåtgärder måste vidtas när denna utrustning används.

## Class I Division 2

The product has been evaluated to the requirements of UL and the Canadian National Standard:

**USL** – ANSI/ISA 12.12.01-2015, Nonincendive Electrical Equipment for Use in Class I and II, Division 2 and Class III, Divisions 1 and 2 Hazardous (Classified) Locations, Approved 21 August 2015.

**CNL** – CAN/CSA C22.2 NO. 213-16, Nonincendive Electrical Equipment for Use in Class I and II, Division 2 and Class III, Divisions 1 and 2 Hazardous (Classified) Locations, Approved May 2016.

**Note:** USL = United States Standards – Listed. CNL = Canadian National Standards – Listed.

These devices are open-type devices that are to be installed in an enclosure only accessible with the use of a tool, suitable for the environment.

“This equipment is suitable for use in Class I, Division 2, Groups A, B, C, and D or non-hazardous locations only.”

**WARNING** – EXPLOSION HAZARD. DO NOT DISCONNECT WHILE THE CIRCUIT IS LIVE OR UNLESS THE AREA IS FREE OF IGNITIBLE CONCENTRATIONS.

Ces périphériques sont des périphériques ouverts qui doivent être installés dans un boîtier uniquement accessibles avec l'utilisation d'un outil, adapté à l'environnement.

"Cet équipement est adapté à l'utilisation dans les classes I, Division 2, Groupes A, B, C et D ou des sites non dangereux seulement".

**AVERTISSEMENT** - RISQUE D'EXPLOSION. NE DÉCONNECTEZ PAS QUE LE CIRCUIT EST VIVANT OU À MOINS QUE LA ZONE EST LIBRE DE CONCENTRATIONS IGNITIVE.



## 7. Service, Warranty & Tech Support

### Warranty

#### Five-Year Limited Hardware Warranty

Transition Networks warrants to the original consumer or purchaser that each of its SISPM1040-384-LRT-C and SISPM1040-362-LRT products and all components thereof, will be free from defects in material and/or workmanship for a period of five years from the original factory shipment date. Any warranty hereunder is extended to the original consumer or purchaser and is not assignable. Transition Networks makes no express or implied warranties including, but not limited to, any implied warranty of merchantability or fitness for a particular purpose, except as expressly set forth in this warranty. In no event shall Transition Networks be liable for incidental or consequential damages, costs, or expenses arising out of or in connection with the performance of the product delivered hereunder. Transition Networks will in no case cover damages arising out of the product being used in a negligent fashion or manner.

This warranty does not cover damage from accident, acts of God, neglect, contamination, misuse or abnormal conditions of operation or handling, including over-voltage failures caused by use outside of the product's specified rating, or normal wear and tear of mechanical components.

Transition Networks will, at its option:

- Repair the defective product to functional specification at no charge
- Replace the product with an equivalent functional product
- Refund a portion of purchase price based on a depreciated value

To return a defective product for warranty coverage, contact Transition Networks' Customer Support for a return authorization number.

Send the defective product postage and insurance prepaid to the following address:

Transition Networks, Inc.  
10900 Red Circle Drive  
Minnetonka, MN 55343  
USA

Attn: RETURNS DEPT: CRA/RMA # \_\_\_\_\_

Failure to properly protect the product during shipping may void this warranty. The return authorization number must be written on the outside of the carton to ensure its acceptance. We cannot accept delivery of any equipment that is sent to us without a CRA or RMA number.

CRA's are valid for 60 days from the date of issuance. An invoice will be generated for payment on any unit(s) not returned within 60 days.

Upon completion of a demo/ evaluation test period, units must be returned or purchased within 30 days. An invoice will be generated for payment on any unit(s) not returned within 30 days after the demo/ evaluation period has expired.

The customer must pay for the non-compliant product(s) return transportation costs to Transition Networks for evaluation of said product(s) for repair or replacement. Transition Networks will pay for the shipping of the repaired or replaced in-warranty product(s) back to the customer (any and all customs charges, tariffs, or/and taxes are the customer's responsibility).

Before making any non-warranty repair, Transition Networks requires a \$200.00 charge plus actual shipping costs to and from the customer. If the repair is greater than \$200.00, an estimate is issued to the customer for authorization of repair. If no authorization is obtained, or the product is deemed not repairable, Transition Networks will retain the \$200.00 service charge and return the product to the customer not repaired. Non-warranted products that are repaired by Transition Networks for a fee will carry a 180-day limited warranty. All warranty claims are subject to the restrictions and conventions set forth by this document.

Transition Networks reserves the right to charge a \$50 fee for all testing and shipping incurred, if after testing, a return is classified as "No Problem Found."

THIS WARRANTY IS YOUR ONLY REMEDY. NO OTHER WARRANTIES, SUCH AS FITNESS FOR A PARTICULAR PURPOSE, ARE EXPRESSED OR IMPLIED. TRANSITION NETWORKS IS NOT LIABLE FOR ANY SPECIAL, INDIRECT, INCIDENTAL OR CONSEQUENTIAL DAMAGES OR LOSSES, INCLUDING LOSS OF DATA, ARISING FROM ANY CAUSE OR THEORY. AUTHORIZED RESELLERS ARE NOT AUTHORIZED TO EXTEND ANY DIFFERENT WARRANTY ON TRANSITION NETWORKS'S BEHALF.

## Contact Us

### Technical Support

**Technical Support:** Technical support is available 24-hours a day

US and Canada: 1-800-260-1312

International: 00-1-952-941-7600

### Main Office

tel: +1.952.941.7600 | toll free: 1.800.526.9267 | fax: 952.941.2322

[sales@transition.com](mailto:sales@transition.com) | [techsupport@transition.com](mailto:techsupport@transition.com) | [customerservice@transition.com](mailto:customerservice@transition.com)

### Address

Transition Networks

10900 Red Circle Drive

Minnetonka, MN 55343, U.S.A.

**Web:** <https://www.transition.com>



Transition Networks

10900 Red Circle Drive

Minnetonka, MN 55343 USA

tel: +1.952.941.7600 | toll free: 1.800.526.9267 | fax: 952.941.2322

Copyright© 2017-2021 Transition Networks. All rights reserved. Printed in the U.S.A.

SISPM1040-384-LRT-C and SISPM1040-362-LRT Install Guide, 33727 Rev. H