



SM24T6DPA

Managed Layer 2 Gigabit Ethernet Switch

(20) 10/100/1000Base-T Ports + (4) 100/1000Base-X SFP/RJ-45 Combo Ports + (2) 100/1000Base-X SFP Slots



Install Guide

33664 Rev. C

Safety Warnings and Cautions

These products are not intended for use in life support products where failure of a product could reasonably be expected to result in death or personal injury. Anyone using this product in such an application without express written consent of an officer of Transition Networks does so at their own risk and agrees to fully indemnify Transition Networks for any damages that may result from such use or sale.



Attention: this product, like all electronic products, uses semiconductors that can be damaged by ESD (electrostatic discharge). Always observe appropriate precautions when handling.



NOTE: Emphasizes important information or calls your attention to related features or instructions.



WARNING: Alerts you to a potential hazard that could cause personal injury.



CAUTION: Alerts you to a potential hazard that could cause loss of data or damage the system or equipment.

SM24T6DPA Managed Layer 2 Gigabit Ethernet Switch Install Guide, 33664 Rev. C

Record of Revisions

Rev	Date	Description of Changes
A	11/24/15	Initial release for software v v6.46.
B	9/5/19	Revise Product Label to include UL certification. Add power connection information. Update to FW v 6.54.3202.
C	7/28/21	Add MTBF and update features. Update Safety certification from EN60950 or IEC60950 to IEC62368-1/EN62368-1.

Trademark notice: All trademarks and registered trademarks are the property of their respective owners. All other products or service names used in this publication are for identification purposes only and may be trademarks or registered trademarks of their respective companies. All other trademarks or registered trademarks mentioned herein are the property of their respective holders.

Copyright restrictions: © 2015-2021 Transition Networks, Inc. All rights reserved. No part of this work may be reproduced or used in any form or by any means (graphic, electronic, or mechanical) without written permission from Transition Networks.

Address comments on this product or manual to: **Transition Networks Inc.**

10900 Red Circle Drive, Minnetonka, MN 55343 | Telephone: +1-952-941-7600 /

Toll Free: 800-526-9267 / Fax: 952-941-2322 | E-Mail: customerservice@transition.com /

Contents

Safety Warnings and Cautions	2
Contents	3
Introduction.....	5
Overview	5
Hardware Description.....	5
Switch Architecture	5
Network Management Options	5
Front Panel	6
Back Panel	6
1000BASE-T Ports.....	6
SFP Transceiver Slots	6
Port and System Status LEDs.....	7
Port Status LEDs	7
System Status LED.....	7
Power Supply Socket	7
Network Planning	7
Introduction to Switching.....	7
Application Examples	8
Installing the Switch.....	8
Selecting a Site	8
Ethernet Cabling.....	9
Equipment Checklist.....	9
Package Contents.....	9
Mounting.....	11
Rack Mounting.....	11
Desktop or Shelf Mounting:.....	12
Installing an Optional SFP Transceiver	12
Connecting to the Console Port	13
Serial Cable Wiring.....	13
Plug in the Console Port.....	13
Connecting to a Power Source	14
Inserting the Power Cord to AC Power Socket.....	14
Reset Button.....	14
Web-based Management.....	15
Making Network Connections	15
Connecting Network Devices	15
Twisted-Pair Devices	15
Cabling Guidelines	15
Connecting to PCs, Servers, Hubs and Switches	16
Network Wiring Connections.....	16
Fiber Optic SFP	17
Cable Labeling and Connection Records.....	18
Troubleshooting.....	19
Basic Troubleshooting Tips.....	19

Troubleshooting Chart.....	20
Troubleshooting Power and Cooling Problems	20
Installation	20
In-Band Access	20
Cables	21
Twisted-Pair Cable and Pin Assignments	21
RJ-45 Connector Pin Numbers	21
10/100BASE-TX MDI and MDI-X Port Pinouts.....	21
10/100BASE-TX MDI and MDI-X Port Pinouts.....	22
Cable Testing for Existing Category 5 Cable	22
Adjusting Existing Cat 5 Cabling to Run 1000BASE-T	22
Specifications.....	23
Physical Characteristics	23
Switch Features	24
Management Features	24
Standards	24
Compliance	24
FCC-CLASS A	25
CE MARK DECLARATION OF CONFORMANCE FOR EMI AND SAFETY (EEC).....	25
EMC	25

Introduction

Overview

The SM24T6DPA 24-Port Switch is an affordable managed switch that provides a reliable infrastructure for your business network. The switch delivers intelligent features to improve the availability of your critical business applications, protect your sensitive information, and optimize your network bandwidth to deliver information and applications more effectively. Easy to set up and use, it provides the ideal combination of affordability and capabilities to your Networking in Small Business or enterprise applications.

PURPOSE

This manual describes how to install, mount, connect, and troubleshoot the switch.

AUDIENCE

The guide is intended for use by network administrators who are responsible for operating and maintaining network equipment; consequently, it assumes a basic working knowledge of general switch functions, the Internet Protocol (IP), and Simple Network Management Protocol (SNMP).

RELATED MANUALS

The following manuals give specific information on how to operate the switch:

- SM24T6DPA Quick Start Guide, 33670
- SM24T6DPA User Guide, 33666
- SM24T6DPA CLI Reference, 33665
- Release Notes (version specific)

Hardware Description

Switch Architecture

The switch performs a wire-speed, non-blocking switching fabric. This allows wire-speed transport of multiple packets at low latency on all ports simultaneously. The switch also features full-duplex capability on all ports, which effectively doubles the bandwidth of each connection. This switch uses store-and-forward technology to ensure maximum data integrity. With this technology, the entire packet must be received into a buffer and checked for validity before being forwarded. This prevents errors from being propagated throughout the network

Network Management Options

The switch can also be managed over the network with a web browser or Telnet application. The switch includes a built-in network management agent that allows it to be managed in-band using SNMP or RMON (Groups 1, 2, 3, 9) protocols. It also has an RJ45 console port connector on the front panel for out-of-band management. A PC may be connected to this port for configuration and monitoring out-of-band via a null-modem serial cable.



NOTE: For a detailed description of the management features, see the Web User Guide.

Front Panel

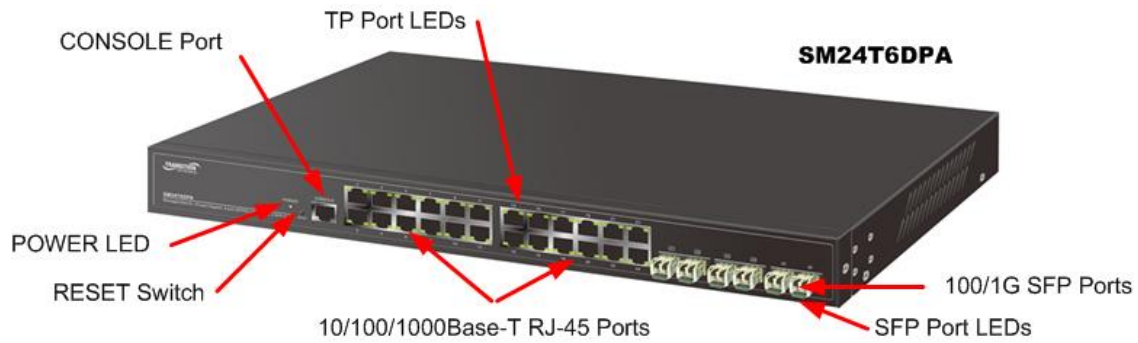

Back Panel



1000BASE-T Ports

The switch contains 24 10/100/1000BASE-T RJ-45 ports. All RJ-45 ports support automatic MDI/MDI-X operation, auto-negotiation and IEEE 802.3x auto-negotiation of flow control, so the optimum data rate and transmission can be selected automatically.

SFP Transceiver Slots

SM24T6DPA supports Small Form Factor Pluggable (SFP) transceiver slots that are shared with RJ-45 port 21 to 24. In the default configuration, if an SFP transceiver (purchased separately) is installed in a slot and has a valid link on the port, the associated RJ-45 port is disabled. For more SFP information, see the TN SFP webpage at <https://www.transition.com/lines/optical-devices/platform-sfp/>

Port and System Status LEDs

The SM24T6DPA switch includes a display panel for system and port indications that simplify installation and network troubleshooting. The LEDs are located on left side of the front panel for easy viewing. Details are shown below and described in the following tables.

Port Status LEDs

LED	Condition	Status
TP (Link/ACT)	Green	Lit Green when TP link good Blinks when any traffic is present
TP SPEED	Green	Lit Green when TP link on 1000Mbps Blinks when TP link on 100Mbps Off when TP link on 10Mbps
SFP (Link/ACT)	Green/Amber	Lit Green when SFP link on 1000Mbps speed Lit Amber when SFP link on 100Mbps speed Blinks when any traffic is present

System Status LED

LED	Condition	Status
Power	Green Off	Lit when power is coming up

Power Supply Socket

There is a power socket on the rear panel of the switch. For normal power supply, the SM24T6DPA Switch has standard power socket for AC power cord.

Power Cord Included: To order the corresponding country-specific power cord, add the extension to the end of the SKU; for example, SM24T6DPA-NA = North America, -LA = Latin America, -EU = Europe, -UK = United Kingdom, -SA = South Africa, -JP = Japan, -OZ = Australia, and -BR = Brazil.

Network Planning

Introduction to Switching

A network switch allows simultaneous transmission of multiple packets; it can partition a network more efficiently than bridges or routers. Therefore, the switch has been recognized as one of the most important devices for today's networking technology.

When performance bottlenecks are caused by congestion at a network access point such as a file server, the device can be connected directly to a switched port. And, by using full-duplex mode, the bandwidth of the dedicated segment can be doubled to maximize throughput.

When networks are based on repeater (hub) technology, the distance between end stations is limited by a maximum hop count. However, a switch can subdivide the network into smaller, more manageable segments, and link them to the larger network; it then turns the hop count back to zero and removes the limitation.

A switch can be easily configured in any Ethernet, Fast Ethernet, or Gigabit Ethernet network to significantly increase bandwidth while using conventional cabling and network cards.

Application Examples

The SM24T6DPA switch has 24 Gigabit copper ports and two 100/1000 dual speed SFPs. It is designed to segment your network, and to provide a wide range of options in setting up network connections. Some typical applications are:

- Work group switch used in Enterprise or SMB
- Peer-to-peer application used in two remote offices
- Office network
- High Performance requirement environment
- Advance security for network safety application
- Data/voice and video conference application

Installing the Switch

Selecting a Site

The switch can be mounted on a flat surface or in a standard 19-inch rack using mounting brackets. Follow the guidelines below when choosing a location. The site should:

- Be at the center of all the devices you want to link and near a power outlet.
- Be able to maintain its temperature within 0 to 40°C (32 to 104 °F) and its humidity within 10% to 90%, non-condensing.
- Be accessible for installing, cabling and maintaining the devices.
- Allow the status LEDs to be clearly visible.

Make sure the twisted-pair Ethernet cable is always routed away from power lines, radios, transmitters or any other electrical interference.

Make sure that SM24T6DPA Switch is connected to a separate grounded power outlet that provides 100 to 240 VAC, 50 to 60 Hz.

Ethernet Cabling

To ensure proper operation when installing the switch into a network, make sure that the current cables are suitable for 100BASE-TX or 1000BASE-T operation. Check the following criteria against the current installation of your network:

- Cable type: Unshielded twisted pair (UTP) or shielded twisted pair (STP) cable with RJ-45 connectors; Category 5 or Category 5e with maximum length of 100 meters is recommend 100BASE-TX, and Category 5e or 6 with maximum length of 100 meters is recommend for 1000BASE-T.
- Protection from radio frequency interference emissions.
- Electrical surge suppression.
- Separation of electrical wires and data based network wiring.
- Safe connections with no damaged cables, connectors or shields.

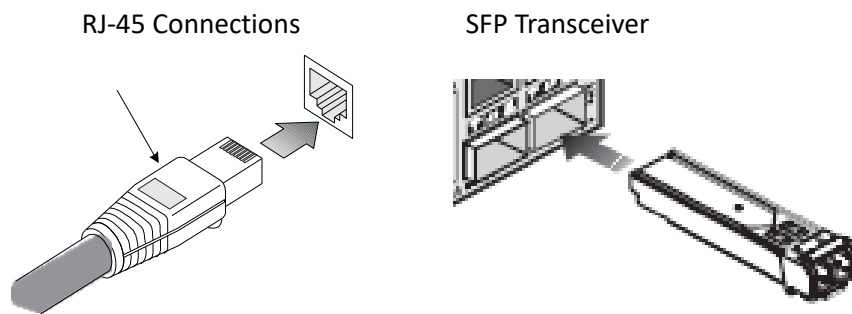

Equipment Checklist

After unpacking this switch, check the contents to be sure you have received all the components. Then, before beginning the installation, be sure you have all other necessary installation equipment.

Package Contents

- SM24T6DPA Management Switch
- Four adhesive rubber feet
- Mounting Accessory (for 19" Rack Shelf)
- Documentation Post card
- Printed Quick Start Guide
- AC Power Cord
- RS-232 to RJ-45 Console Cable

Notify your sales representative immediately if any of these items are missing or damaged

 **WARNING:** The mini-GBICs are Class 1 laser devices. Avoid direct eye exposure to the beam coming from the transmit port.

 **CAUTION:** Circuit devices are sensitive to static electricity, which can damage their delicate electronics. Dry weather conditions or walking across a carpeted floor may cause you to acquire a static electrical charge. To protect your device, always:

- Touch the metal chassis of your computer to ground the static electrical charge before you pick up the circuit device.
- Pick up the device by holding it on the left and right edges only.
- If you need using outdoor device connect to this device with cable then you need to addition an arrester on the cable between outdoor device and this device.

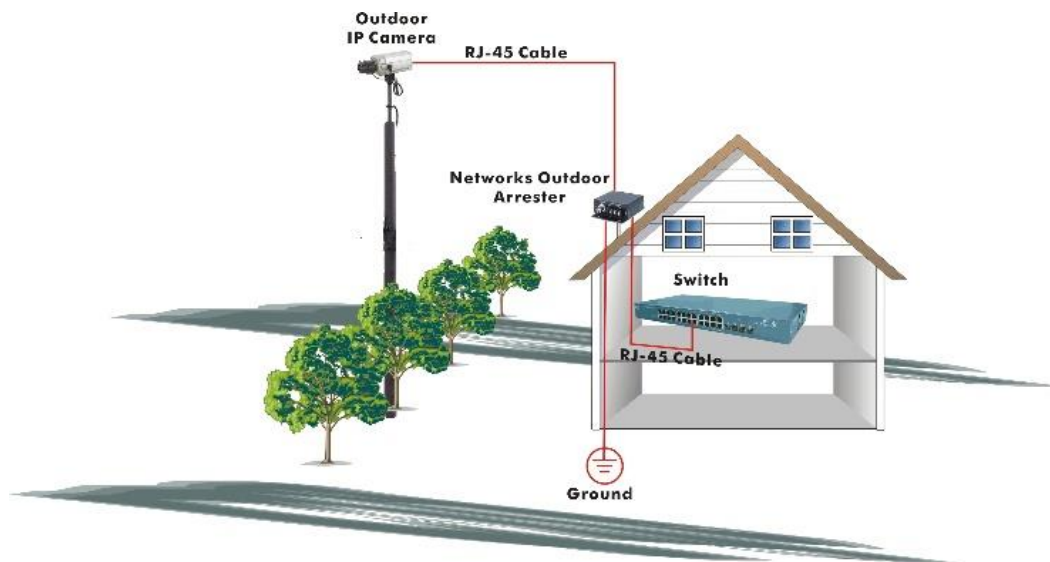

Add an arrester between outdoor device and this switch

 **NOTE:** The switch is indoor device; if it will be used in outdoor environment or connects with some outdoor device, then it must use a lightning arrester to protect the switch

 **WARNING:**

- Self-demolition on Product is strictly prohibited. Damage caused by self-demolition will be charged for repairing fees.
- Do not place product outdoor or in a sandstorm.
- Before installation, make sure input power supply and product specifications are compatible.
- To reduce the risk of electric shock, disconnect all AC or DC power cord and RPS cables to completely remove power from the unit.
- Before importing / exporting configuration make sure the firmware version is the same.
- After firmware upgrade, the switch will automatically change the configuration to latest firmware version.

Mounting

The switch can be mounted in a standard 19-inch equipment rack or on a desktop or shelf. Mounting instructions for each type of site as follows.

Rack Mounting

- **Temperature:** Since the temperature within a rack assembly may be higher than the ambient room temperature, check that the rack-environment temperature is within the specified operating temperature range (0 to 40 °C).
- **Mechanical Loading:** Do not place any equipment on top of a rack-mounted unit.
- **Circuit Overloading:** Be sure that the supply circuit to the rack assembly is not overloaded.
- **Grounding:** Rack-mounted equipment should be properly grounded.

Step 1. Attach the brackets to the device using the screws provided in the Mounting Accessory.

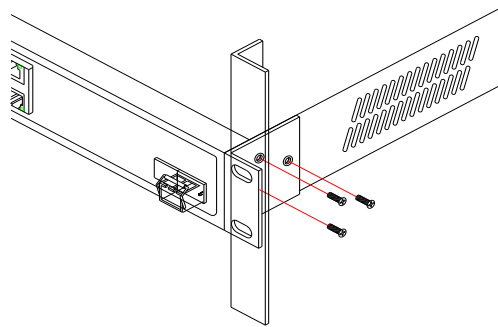

Step 2. Mount the device in the rack (via Optional Rack-Mount kit), using four rack-mounting screws (not provided). Be sure to secure the lower rack-mounting screws first to prevent the brackets being bent by the weight of the switch.

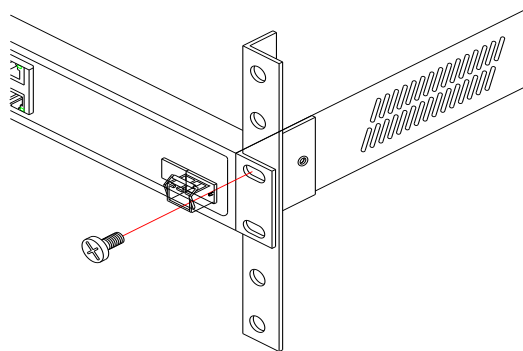

Step 3. If installing a single switch only, turn to “Connection to a Power Source” at the end of this chapter.

Step 4. If installing multiple switches, mount them in the rack, one below the other, in any order

Desktop or Shelf Mounting:

Step 1. Attach the four adhesive rubber feet to the bottom of the first switch.

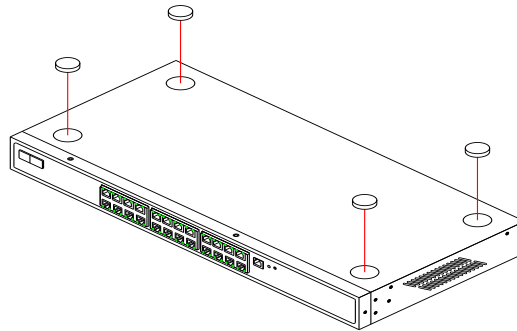

Step 2. Set the device on a flat surface near an AC power source; make sure there are at least two inches of space on all sides for proper air flow.

Step 3. If installing a single switch only, go to “Connecting to a Power Source” at the end of this chapter.

Step 4. If installing multiple switches, attach four adhesive feet to each one. Place each device squarely on top of the one below, in any order.

Installing an Optional SFP Transceiver

You can install or remove an SFP without having to power off the switch. The SFP is hot-pluggable. Inserting an SFP Transceiver into an open SFP slot:

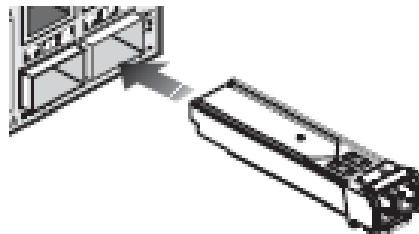

Step 1. Consider network and cabling requirements to select an appropriate SFP transceiver.

Step 2. Insert the transceiver with the optical connector facing outward and the slot connector facing down. Note that SFP transceivers are keyed so they can only be installed in one orientation.

Step 3. Slide the SFP transceiver into the slot until it clicks into place.



NOTE: SFP transceivers are not provided in the switch package.

Connecting to the Console Port

The RJ-45 serial port on the switch's front panel is used to connect to the switch for out-of-band console configuration. The command line driven configuration program can be accessed from a terminal or a PC running a terminal emulation program. The pin assignments used to connect to the serial port are provided below.

Serial Cable Wiring

Switch's 8-Pin Serial Port	Null Modem	PC's 9-Pin DTE Port
2 RXD (receive data)	←-----	3 TXD (transmit data)
3 RXD (receive data)	-----→	2 RXD (receive data)
5 SGND (Signal ground)	-----	5 SGND (Signal ground)



NOTE: No other pins are used.

Plug in the Console Port

The serial port's configuration requirements are:

- Default Baud rate—115,200 bps
- Character Size—8 Characters
- Parity—None
- Stop bit—One
- Data bits—8
- Flow control—none

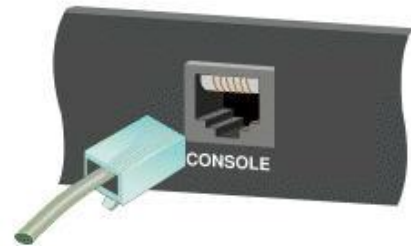

Connecting to a Power Source

You can plug or remove the power cord from an AC power socket to turn power on and off.

Inserting the Power Cord to AC Power Socket

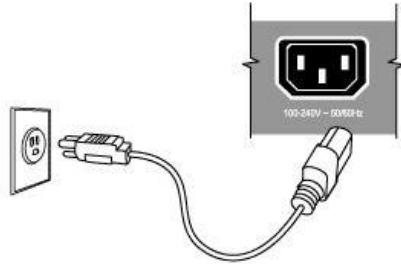

Step 1. Insert the power cable plug directly into the AC Socket located at the back of the switch.

Step 2. Plug the other end of the cable into a grounded, 3-Pin, AC power source.

Step 3. Check the front panel LEDs as the device is powered on to be sure the POWER LED is lit. If not, check that the power cable is correctly plugged in.



WARNING: For International use, you may need to change the AC line cord. You must use a line cord set that has been approved for the socket type in your country.

Reset Button

The front panel Reset button can be used to reset the switch. Use a paper clip or similar tool to press the recessed Reset button.

Web-based Management

The switch default values are listed below:

IP Address	192.168.1.77
Subnet Mask	255.255.255.0
Default Gateway	192.168.1.254
Username	admin
Password	admin

After the managed switch has been configured in the CLI via the switch's serial interface, you can browse it. Type 192.168.1.77 in the address row in a browser; the following screen displays, prompting you for a username and password.

A screenshot of a web-based management login interface. It features a light gray background with a white rectangular area containing two input fields. The top field is empty, and the bottom field is labeled "Password". Below the input fields is a blue button with the text "Login" in white.

The default username and password are both “**admin**”. For first time use, enter the default username and password, and then click the **Login** button. The login process now is complete.

Making Network Connections

Connecting Network Devices

The switch is designed to be connected to 10, 100 or 1000Mbps network cards in PCs and servers, as well as to other switches and hubs. It may also be connected to remote devices using optional SFP transceivers.

Twisted-Pair Devices

Each device requires an unshielded twisted-pair (UTP) cable with RJ-45 connectors at both ends. Use Category 5, 5e or 6 cable for 1000BASE-T connections, Category 5 or better for 100BASE-TX connections.

Cabling Guidelines

The RJ-45 ports on the switch support automatic MDI/MDI-X pinout configuration, so you can use standard straight-through twisted-pair cables to connect to any other network device (PCs, servers, switches, routers, or hubs).



CAUTION: Do not plug a phone jack connector into an RJ-45 port. This will damage the switch. Use only twisted-pair cables with RJ-45 connectors that conform to FCC standards.

Connecting to PCs, Servers, Hubs and Switches

Step 1. Attach one end of a twisted-pair cable segment to the device's RJ-45 connector.

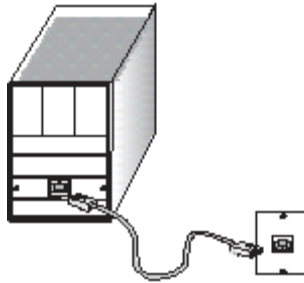

Step 2. If the device is a network card and the switch is in the wiring closet, attach the other end of the cable segment to a modular wall outlet connected to the wiring closet. See the section "Network Wiring Connections". Otherwise, attach the other end to an available port on the switch. Make sure each twisted pair cable does not exceed 100 meters (328 ft) long



NOTE: Avoid using flow control on a port connected to a hub unless it is actually required to solve a problem. Otherwise back pressure jamming signals may degrade overall performance for the segment attached to the hub.

Step 3. As each connection is made, the switch Link LED corresponding to each port will light green (1000 Mbps) or amber (100 Mbps) to indicate the connection is valid.

Network Wiring Connections

The punch-down block is an integral part of many of the newer equipment racks. It is actually part of the patch panel. Instructions for making connections in the wiring closet with this type of equipment follows.

Step 1. Attach one end of a patch cable to an available port on the switch, and the other end to the patch panel.

Step 2. If not already in place, attach one end of a cable segment to the back of the patch panel where the punch-down block is located, and the other end to a modular wall outlet.

Step 3. Label the cables to simplify future troubleshooting. See "Cable Labeling and Connection Records" on page 29.

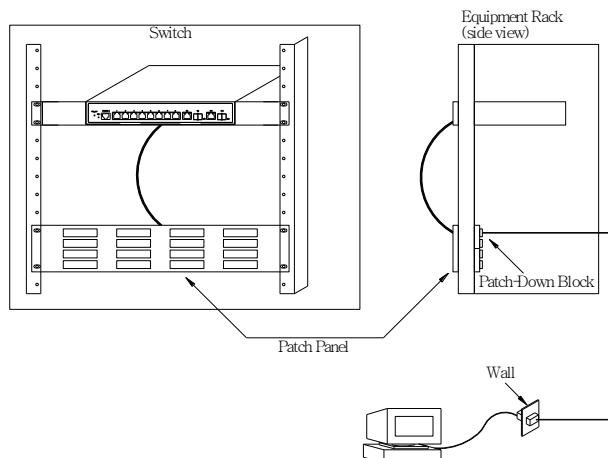

Fiber Optic SFP

An optional Gigabit SFP transceiver can be used for a backbone connection between switches, or for connecting to a high-speed server.

Each single-mode fiber port requires 9/125 micron single-mode fiber optic cable with an LC connector at both ends. Each multimode fiber optic port requires 50/125 or 62.5/125 micron multimode fiber optic cabling with an LC connector at both ends.



WARNING: This switch uses lasers to transmit signals over fiber optic cable. The lasers are inherently eye safe in normal operation. However, never look directly at a transmit port when it is powered on.



WARNING: When selecting a fiber SFP device, considering safety, make sure that it can function at a temperature that is not less than the recommended maximum operational temperature of the product. You must also use an approved Laser SFP transceiver.

Step 1. Remove and keep the LC port's rubber plug. When not connected to a fiber cable, the rubber plug should be replaced to protect the optics.

Step 2. Check that the fiber terminators are clean. You can clean the cable plugs by wiping them gently with a clean tissue or cotton ball moistened with a little ethanol. Dirty fiber terminators on fiber optic cables will impair the quality of the light transmitted through the cable and lead to degraded performance on the port.

Step 3. Connect one end of the cable to the LC port on the switch and the other end to the LC port on the other device. Since LC connectors are keyed, the cable can be attached in only one orientation. Damage may occur if forced in the wrong orientation.

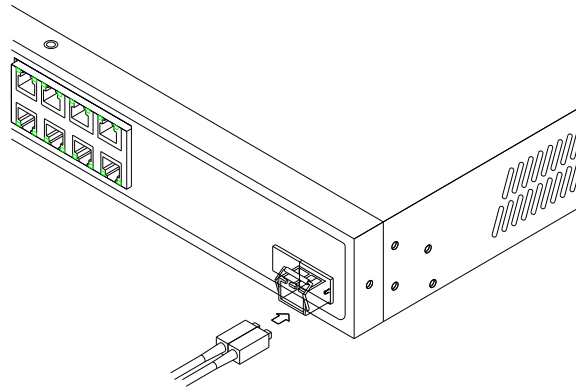

Step 4. As a connection is made, check the Link LED on the switch corresponding to the port to be sure that the connection is valid.

1000BASE-T Cable Requirements

When adding hubs to your network, please note that because switches break up the path for connected devices into separate collision domains, you should not include the switch or connected cabling in your calculations for cascade length involving other devices.

All Category 5 UTP cables that are used for 100BASE-TX connections should also work for 1000BASE-T, providing that all four wire pairs are connected. However, it is recommended that for all critical connections, or any new cable installations, Category 5e or Category 6 cable should be used. The Category 5e and 6 specifications include test parameters that are only recommendations for Category 5. Therefore, the first step in preparing existing Category 5 cabling for running 1000BASE-T is a simple test of the cable installation to be sure that it complies with the IEEE 802.3-2005 standards

Cable Labeling and Connection Records

When planning a network installation, it is essential to label the opposing ends of cables and to record where each cable is connected. This will allow user to easily locate inter-connected devices, isolate faults and change your topology without need for unnecessary time consumption.

To best manage the physical implementations of your network, follow these guidelines:

- Clearly label the opposing ends of each cable.
- Using your building's floor plans, draw a map of the location of all network-connected equipment. For each piece of equipment, identify the devices to which it is connected.
- Note the length of each cable and the maximum cable length supported by the switch ports.
- For ease of understanding, use a location-based key when assigning prefixes to your cable labeling.
- Use sequential numbers for cables that originate from the same equipment.
- Differentiate between racks by naming accordingly.
- Label each separate piece of equipment.
- Display a copy of your equipment map, including keys to all abbreviations at each equipment rack.

Troubleshooting

Most problems are caused by the following situations. Check for these items first when starting your troubleshooting.

Basic Troubleshooting Tips

Connecting to devices that have a fixed full- duplex configuration.

The RJ-45 ports are configured as “Auto”. That is, when connecting to attached devices, the switch will operate in one of two ways to determine the link speed and the communication mode (half duplex or full duplex):

- If the connected device is also configured to Auto, the switch will automatically negotiate both link speed and communication mode.
- If the connected device has a fixed configuration, for example 100Mbps, at half or full duplex, the switch will automatically sense the link speed, but will default to a communication mode of half duplex.

Because the SM24T6DPA behaves this way (in compliance with the IEEE802.3 standard), if a device connected to the switch has a fixed configuration at full duplex, the device will not connect correctly to the switch. The result will be high error rates and very inefficient communications between the switch and the device.

Make sure all devices connected to the SM24T6DPA are configured to auto negotiate or are configured to connect at half duplex (all hubs are configured this way, for example).

Faulty or loose cables. Look for loose or obviously faulty connections. If they appear to be OK, make sure the connections are snug. If that does not correct the problem, try a different cable.

Non-standard cables. Non-standard and miswired cables may cause network collisions and other network problems and can seriously impair network performance. Use a new correctly-wired cable. For pinouts and correct cable wiring. A category 5 cable tester is a recommended tool for every 100Base-TX and 1000Base-T network installation.

Improper Network Topologies. It is important to make sure you have a valid network topology. If you no longer experience the problems, the new topology is probably at fault. In addition, you should make sure that your network topology contains no data path loops

Check the port configuration.

A port on the switch may not be operating as you expect because it has been put into a “ blocking” state by Spanning Tree, GVRP (automatic VLANs), or LACP (automatic trunking). (Note that the normal operation of the Spanning Tree, GVRP, and LACP features may put the port in a blocking state.) Or the port just may have been configured as disabled through software.

Troubleshooting Chart

Symptom	Action
POWER LED is Off	<ol style="list-style-type: none"> 1. Check connections between the switch, the power cord and the wall outlet. 2. Contact your dealer for assistance.
Link LED is Off	<ol style="list-style-type: none"> 1. Verify that the switch and attached device are powered on. 2. Be sure the cable is plugged into the switch and corresponding device. 3. If the switch is installed in a rack, check the connections to the punch-down block and patch panel. 4. Verify that the proper cable type is used, and its length does not exceed specified limits. 5. Check the adapter on the attached device and cable connections for possible defects. Replace the defective adapter or cable if necessary.

Troubleshooting Power and Cooling Problems

Installation

If the power indicator does not turn on when the power cord is plugged in, you may have a problem with the power outlet, power cord, or internal power supply. However, if the unit powers off after running for a while, check for loose power connections, power losses or surges at the power outlet. If you still cannot isolate the problem, the internal power supply may be defective. Verify that all system components have been properly installed. If one or more components appear to be malfunctioning (such as the power cord or network cabling), test them in an alternate environment where you are sure that all the other components are functioning properly.

In-Band Access

You can access the management agent in the switch from anywhere within the attached network using Telnet or a web browser. However, you must first configure the switch with a valid IP address, subnet mask, and default gateway. If you have trouble establishing a link to the management agent, check to see if you have a valid network connection. Then verify that you entered the correct IP address. Also, be sure the port through which you are connecting to the switch has not been disabled. If it has not been disabled, then check the network cabling that runs between your remote location and the switch.



NOTE: The management agent accepts up to four simultaneous Telnet sessions. If the maximum number of sessions already exists, an additional Telnet connection will not be able to log into the system.

Cables

Twisted-Pair Cable and Pin Assignments

For 10/100BASE-TX connections, the twisted-pair cable must have two pairs of wires. For 1000BASE-T connections the twisted-pair cable must have four pairs of wires. Each wire pair is identified by two different colors. For example, one wire might be green and the other, green with white stripes. Also, an RJ-45 connector must be attached to both ends of the cable.



CAUTION: DO NOT plug a phone jack connector into any RJ-45 port. Use only twisted-pair cables with RJ-45 connectors that conform to FCC standards.



CAUTION: Each wire pair must be attached to the RJ-45 connectors in a specific orientation.

The figure below illustrates how the pins on the RJ-45 connector are numbered. Be sure to hold the connectors in the same orientation when attaching the wires to the pins.

RJ-45 Connector Pin Numbers

The figure below illustrates how the pins on the RJ-45 connector are numbered. Be sure to hold the connectors in the same orientation when attaching the wires to the pins.

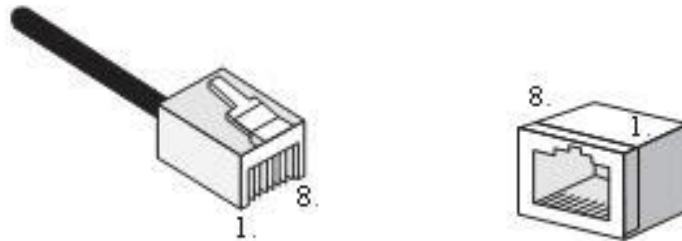

10/100BASE-TX MDI and MDI-X Port Pinouts

Pin	MDI Signal Name	MDI-X Signal Name
1	Transmit Data plus (TD+)	Receive Data plus (RD+)
2	Transmit Data minus (TD-)	Receive Data minus (RD-)
3	Receive Data plus (RD+)	Transmit Data plus (TD+)
6	Receive Data minus (RD-)	Transmit Data minus (TD-)
4, 5, 7, 8	Not used	Not used



NOTE: The “+” and “-” signs represent the polarity of the wires that make up each wire pair.

10/100BASE-TX MDI and MDI-X Port Pinouts

All 1000BASE-T ports support automatic MDI/MDI-X operation, so you can use straight-through cables for all network connections to PCs or servers, or to other switches or hubs.

The 1000BASE-T MDI and MDI-X port pinouts. These ports require that all four pairs of wires be connected. Note that for 1000BASE-T operation, all four pairs of wires are used for both transmit and receive.

Use 100-ohm Category 5, 5e or 6 unshielded twisted-pair (UTP) or shielded twisted-pair (STP) cable for 1000BASE-T connections. Also be sure that the length of any twisted-pair connection does not exceed 100 meters (328 feet).

Cable Testing for Existing Category 5 Cable

Installed Category 5 cabling must pass tests for Attenuation, Near-End Crosstalk (NEXT), and Far-End Crosstalk (FEXT). This cable testing information is specified in the ANSI/TIA/EIA-TSB-67 standard. Additionally, cables must also pass test parameters for Return Loss and Equal-Level Far-End Crosstalk (ELFEXT). These tests are specified in the ANSI/TIA/EIA-TSB-95 Bulletin, "The Additional Transmission Performance Guidelines for 100 Ohm 4-Pair Category 5 Cabling."



NOTE: That when testing your cable installation, be sure to include all patch cables between switches and end devices

Adjusting Existing Cat 5 Cabling to Run 1000BASE-T

If your existing Category 5 installation does not meet one of the test parameters for 1000BASE-T, there are basically three measures that can be applied to try and correct the problem:

1. Replace any Category 5 patch cables with high-performance Category 5e or Category 6 cables.
2. Reduce the number of connectors used in the link.
3. Reconnect some of the connectors in the link.

Specifications

Physical Characteristics

Connectors

- (1) RJ console port
- (20) 10/100/1000 RJ-45 ports
- (4) 100/1000 SFP/RJ-45 combo ports
- (2) 100/1000 SFP slots

Network Interface

- Ports 1-20: RJ-45 connector, auto MDI/X
- 10BASE-T: RJ-45 (100-ohm, UTP cable; Category 3 or better)
- 100BASE-TX: RJ-45 (100-ohm, UTP cable; Category 5 or better)
- 1000BASE-T: RJ-45 (100-ohm, UTP or STP cable; Category 5, 5e or 6)
- *Maximum Cable Length - 100 m (328 ft)
- Ports 21-24: RJ-45 connector/ (100/1000M) SFP
- Ports 25-26: 100/1000M SFP ports

Buffering

1392KB on-chip frame buffer

Backplane

52 Gbps

MAC Addresses

8K MAC address entries

LEDs

- System: POWER
- Copper Port: status (LINK/ACT), 10/100/1000M
- SFP Port: status (LINK/ACT/SPD), 100/1000M

Weight

5.3 lbs. [2.4 kg]

Dimensions

Width: 17.4" [442 mm] x Depth: 8.3" [211 mm] x Height: 1.73" [44 mm]

Operating Temperature

0°C to +50°C (+32° F to +122° F)

Humidity

Operating: 5% to 90% (non-condensing)

Power Input

100~240VAC, 50~60Hz

Power Consumption

20 Watts maximum

MTBF

175,511 hours

Switch Features

Store-and-forward Forwarding Mode
35.712Mpps Throughput
Full Duplex IEEE 802.3x Flow Control
IPv4/IPv6 dual protocol stack
Jumbo Frame up to 9K bytes
Authentication: RADIUS IEEE 802.1X, TACACS+
SSH/SSL Security
Port-based or tagged (IEEE 802.1Q) VLAN, MAC based VLAN, Management VLAN and Private VLAN Edge
DHCP Relay including option 82
L2/L3/L4 ACLs Support MAC ACL, IP standard/extended ACL
IEEE 802.3az Energy Efficiency
IP Source Guard, Port Security
DHCP Server
Device Management System (DMS): Graphic Monitoring, Grouping, Traffic Monitoring

Management Features

In-Band Management SSH v1,v2/SSL, Telnet, SNMP, or HTTP
Out-of-Band Management RS-232 (RJ-45) console port
Software Loading HTTP, TFTP in-band, Console out-of-band

Standards

IEEE 802.3 10Base-T Ethernet (Twisted-pair Copper)
IEEE 802.3u 100Base-TX Ethernet (Twisted-pair Copper)
IEEE 802.3ab 1000Base-TX Ethernet (Twisted-pair Copper)
IEEE 802.3z 1000Base-X Ethernet
IEEE 802.3x Flow Control Capability
ANSI/IEEE 802.3 Auto-negotiation
IEEE 802.1Q VLAN
IEEE 802.1p Class of Service
IEEE 802.1X Access Control
IEEE 802.1D Spanning Tree
IEEE 802.1w Rapid Spanning Tree
IEEE 802.1s Multiple Spanning Tree
IEEE 802.3ad Link Aggregation Control Protocol (LACP)
IEEE 802.1AB Link Layer Discovery Protocol (LLDP)

Compliance

Emissions: EN55022 (CISPR 22) Class A EN 61000-3 ; FCC Class A; CE Mark

Immunity: EN 61000-4-2/3/4/5/6/8/11; EN 55024

July 8, 2019 and after: Add UL mark to Product Label.

This equipment is in accordance with the procedures given in EUROPEAN COUNCIL DIRECTIVE 2004/108/EC. The equipment was Passed the test performed according to European Standard EN 55022:2010/AC:2011 Class A, EN 61000-3-2:2014, EN 61000-3-3:2013 and EN 55024:2010 (IEC 6100-4-2 Edition 2.0 2008-12, IEC 61000-4-3 Edition 3.2 2010-04, IEC 61000-4-4 Edition 3.0 2012-04, IEC 61000-4-5 Edition 2.0 2005-11, IEC 61000-4-6 Edition 3.0 2008-10, IEC 61000-

4-8 Edition 2.0 2009-09, IEC 61000-4-11 Edition 2.0 2004-03) and Australian Standard AS/NZS CISPR 22:2009/A1:2010 Class A.

Verification according to 47 CFR FCC Rules and Regulations Part 15 Subpart B, Class A Digital Device and Canada Standard ICES-003 Issue 5

LOW VOLTAGE DIRECTIVE IEC 62368-1:2014 (Second Edition); and/or EN 62368-1:2014/A11:2017; and/or BS EN 62368-1:2014+A11:2017.

FCC-CLASS A

This equipment has been tested and found to comply with the limits for a Class A computing device pursuant to Subpart J of part 15 of FCC Rules, which are designed to provide reasonable protection against such interference when operated in a commercial environment. This equipment generates, uses, and can radiate radio frequency energy and, if not installed and used in accordance with the instruction manual, may cause harmful interference to radio communications. Operation of this equipment in a residential area is likely to cause harmful interference in which case the user will be required to correct the interference at his own expense.

You are cautioned that changes or modifications not expressly approved by the party responsible for compliance could void your authority to operate the equipment. You may use unshielded twisted-pair (UTP) for RJ-45 connections - Category 3 or better for 10 Mbps connections, Category 5 or better for 100 Mbps connections, Category 5, 5e, or 6 for 1000 Mbps connections. For fiber optic connections, you may use 50/125 or 62.5/125 micron multimode fiber or 9/125 micron single-mode fiber.

CE MARK DECLARATION OF CONFORMANCE FOR EMI AND SAFETY (EEC)

This equipment has been tested and found to comply with the protection requirements of European Emission Standard EN55022/EN61000-3 and the Generic European Immunity Standard EN55024.

EMC

EN55022(2006)+A1:2007/CISPR 22:2006+A1:2006	Class A 4K V CD, 8KV, AD
IEC61000-4-2 (2001)	3V/m
IEC61000-4-3(2002)	1KV – (power line), 0.5KV – (signal line)
IEC61000-4-4(2004)	Line to Line: 1KV, Line to Earth: 2KV
IEC61000-4-5 (2001)	130dBuV(3V) Level 2
IEC61000-4-6 (2003)	1A/m
IEC61000-4-8 (2001)	Voltage dips: >95%, 0.5period, 30%, 25periods
IEC61000-4-11(2001)	Voltage interruptions: >95%, 250periods



Transition Networks
10900 Red Circle Drive
Minnetonka, MN 55343 USA
Tel: 952- 941-7600 or 1-800-526-9267
Fax: 952-941-2322
Copyright© 2015-2021 Transition Networks. All rights reserved.

SM24T6DPA Install Guide, 33664 Rev. C