

LANTRONIX®



SI-IES-1200-LRT Hardened Gigabit PoE/PoE+ Injector User Guide

**Part Number 33586
Revision F June 2022**

Intellectual Property

© 2021 Lantronix, Inc. All rights reserved. No part of the contents of this publication may be transmitted or reproduced in any form or by any means without the written permission of Lantronix.

Lantronix is a registered trademark of Lantronix, Inc. in the United States and other countries.

All other trademarks and trade names are the property of their respective holders.

Patented: <https://www.lantronix.com/legal/patents/>; additional patents pending.

Warranty

For details on the Lantronix warranty policy, go to <http://www.lantronix.com/support/warranty>.

Contacts

Lantronix Corporate Headquarters

7535 Irvine Center Drive

Suite100

Irvine, CA 92618, USA

Toll Free: 800-526-8766

Phone: 949-453-3990

Fax: 949-453-3995

Technical Support

Phone: +1.952.358.3601 or 1.800.260.1312

Email: <https://www.lantronix.com/technical-support/>

Sales Offices

For a current list of our domestic and international sales offices, go to www.lantronix.com/about/contact.

Disclaimer

All information contained herein is provided “AS IS.” Lantronix undertakes no obligation to update the information in this publication. Lantronix does not make, and specifically disclaims, all warranties of any kind (express, implied or otherwise) regarding title, non-infringement, fitness, quality, accuracy, completeness, usefulness, suitability or performance of the information provided herein. Lantronix shall have no liability whatsoever to any user for any damages, losses and causes of action (whether in contract or in tort or otherwise) in connection with the user’s access or usage of any of the information or content contained herein. The information and specifications contained in this document are subject to change without notice.

Revision History

Date	Rev	Comments
1/26/16	B	Note to adjust power supply to 50VDC ~ 53VDC for full PoE+ power.
1/9/17	C	Update specs and DC power input and contact information.
2/23/17	D	Add DoC (Declaration of Conformity).
5/4/17	E	Update MTBF.
6/10/22	F	Initial Lantronix re-brand.

FCC Warning

This Equipment has been tested and found to comply with the limits for a Class A digital device, pursuant to Part 15 of the FCC rules. These limits are designed to provide reasonable protection against harmful interference in a residential installation. This equipment generates, uses, and can radiate radio frequency energy. It may cause harmful interference to radio communications if the equipment is not installed and used in accordance with the instructions. However, there is no guarantee that interference will not occur in a particular installation. If this equipment does cause harmful interference to radio or television reception, which can be determined by turning the equipment off and on, the user is encouraged to try to correct the interference by one or more of the following measures:

- Reorient or relocate the receiving antenna.

- Increase the separation between the equipment and receiver.

- Connect the equipment into an outlet on a circuit different from that to which the receiver is connected.

- Consult the dealer or an experienced radio/TV technician for help.

CE Mark Warning

This is a class A product. In a domestic environment this product may cause radio interference in which case the user may be required to take adequate measures.

Table of Contents

FCC Warning	3
CE Mark Warning	3
Overview	5
Product Description	5
Features	5
Specifications	6
Packing List	6
Optional Accessories (sold separately)	6
Hardware Description	7
Dimensions	7
Front Panel	8
Top View	8
Grounding the PoE Injector	8
Wiring the Power Inputs	9
RJ-45 Pin Assignments	10
10/100Base-TX Cable Schema	11
10/100/1000Base-T Pinouts	11
10/100/1000Base-T Cable Schema	12
Power Supply Specifications	13
25130 Features and Specifications	13
25130 Dimensions	14
Installation	15
DIN-Rail Mounting	15
Assembling the DIN-Rail Clip	15
Mounting the PoE Injector (DIN-Rail)	16
Wall-Mount Plate Mounting	17
Troubleshooting	18
Diagnosing LED Indicators	18
Declaration of Conformity	18

Overview

The SI-IES-1200-LRT is an unmanaged hardened PoE+ injector that adds up to 30 Watts of power on a network segment. Injectors are commonly used to power PoE devices in locations where a power source does not exist. The injector has redundant input power connections, and a fault alarm relay to ensure safe reliable operation in temperatures between -40°C and +75°C.

Lantronix hardened PoE injectors are certified to operate reliably in harsh environments such as those found on factory floors, outdoor enclosures, or other challenging environments.

Product Description

The SI-IES-1200-LRT is a Hardened Gigabit PoE/PoE+ Injector that provides data and DC power through the Ethernet cable to PoE-equipped devices, such as an IP camera, access point, PoE splitter or other equipment supporting IEEE 802.3af/IEEE802.3at. The SI-IES-1200-LRT is typically installed near the Ethernet switch. The figure below provides an example of a Power over Ethernet Injector application.

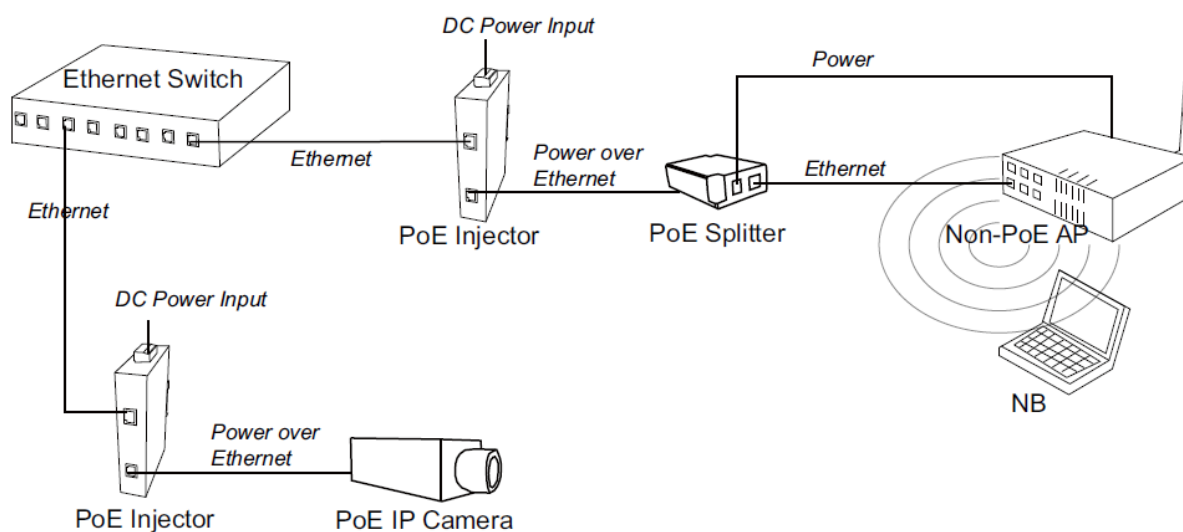

Features

- 10/100/1000BaseT Power over Ethernet Injector
- IEEE 802.3af/IEEE802.3at compliant
- Provides power feeding up to 30 watts
- Overload current protection
- DC power input ranging from 24 - 48VDC
- Wide operating temperature -40 ~ +75 °C
- Link Pass Through
- Non-blocking architecture
- Compact size
- IP30 housing protection
- Wall-Mount brackets included

Specifications

Standards	IEEE802.3 10BASE-T and IEEE802.3u 100BASE-TX IEEE802.3ab 1000Base-T IEEE802.3af/at Power over Ethernet. Compliant with 802.3at in Environment A when using an isolated power supply.
Connectors	LAN port: Data/Signal pins 1, 2, 3, 6 PoE port: Data/Signal pins 1, 2, 3, 6 Power pins [1, 2 (V+)], [3, 6 (V-)] (1) DATA IN RJ-45 Ethernet Port (1) DATA OUT PoE+ RJ-45 Ethernet Port 30 Watts
Network Cable	10BASE-T: 2-pair UTP/STP Cat.3, 4,5 cable EIA/TIA-568 100-ohm (100m) 100BASE-TX: 2-pair UTP/STP Cat.5 cable (Cat. 5e recommended) EIA/TIA-568 100-ohm (100m) 1000Base-T: 4-pair UTP/STP Cat. 5e or above cable EIA/TIA-568 100-ohm (100m)
LEDs	Two Power LEDs; One PoE LED PWR1 (Power): ON=primary power connected PWR2 (Power): ON=backup power connected
Power Input *	24 - 48VDC
Power Consumption	33.36 Watts @ 24 VDC 3.53 Watts (No PoE) 33.36 Watts (1 port PoE)
Operating Temp.	-40° C ~ 75° C (-40° F ~ 167° F)
Storage Temp.	-40 C ~ 85 C (-40° F ~ 185° F)
Humidity	5% ~ 95% Humidity (non-condensing) (Operating/Storage)
Weight	1.3 lbs. [0.59 kg]
EMC	CE, FCC Class A EN61000-6-4, EN61000-6-2; EN61000-4-2 (ESD); EN61000-4-3 (RS); EN61000-4-4 (EFT); EN61000-4-5 (Surge); EN61000-4-6 (CS); EN61000-4-8 (Magnetic Field)
Safety	UL508
MTBF	8,371,781 hours Bellcore Ground Benign, Controlled; Temp. 30 deg. C. 4,185,891 hours Bellcore Ground Fixed, Uncontrolled; Temp. 30 deg. C.
Warranty	Lifetime

* This device is recommended for Environment A. Use of an isolated power supply is recommended.

Packing List

- One Power over Ethernet Injector
- One Wall-mounting Kit
- One DIN-rail mounting clip
- One Documentation Postcard

Optional Accessories (sold separately)

Industrial Power Supply 25130. Input: 85-264VAC, 120-370VDC. Output: 48VDC, .83A, 39.8 Watts.

Hardware Description

Dimensions

The Power over Ethernet Injector dimensions are:

Width: 1.2" [30 mm] x Depth: 3.7" [95 mm] x Height: 5.5" [140 mm]

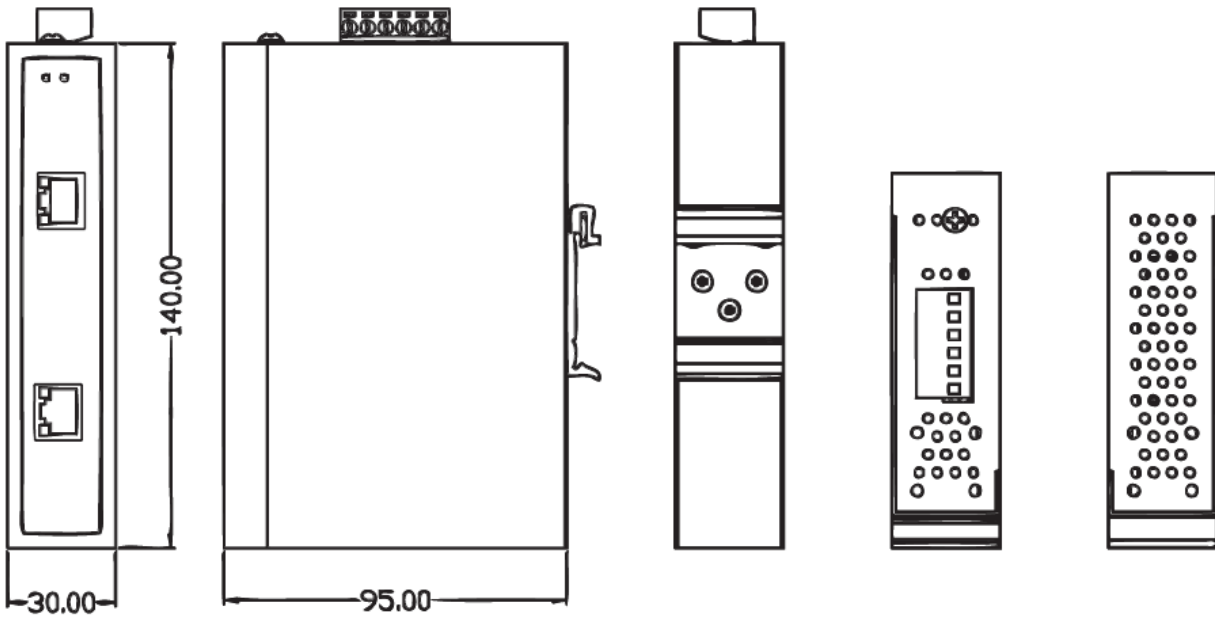

Front Panel

The Power over Ethernet Injector front panel has two RJ-45 ports and three LED indicators.

LAN port: RJ-45 Ethernet port used to connect to the existing Ethernet network.

PoE port: RJ-45 Ethernet port capable of supplying power over the Ethernet cable and providing an Ethernet connection to powered devices.

P1 & P2: The LED indicators light when their respective power inputs are active.

PoE: This LED indicator lights when PoE power is being delivered.

Top View

The SI-IES-1200-LRT is designed with two redundant power inputs which allows you to supply redundant input power in the range of 24 to 48V.



Power Inputs

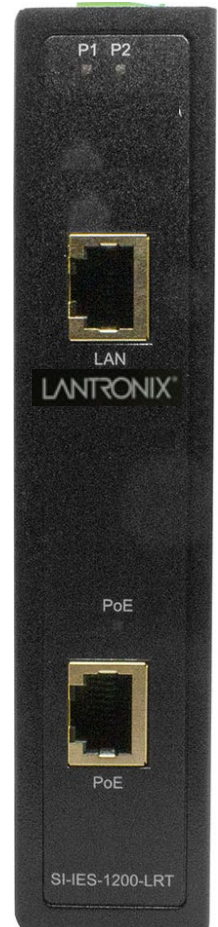

Grounding the PoE Injector

Follow the instructions below to attach the PoE Injector to ground.



Attention! When installing the PoE Injector, the ground connection must always be made first and disconnected last.

1. On the top of the device, locate and remove the dome screw which has a ground symbol beside it.
2. Attach the ground wire to the device enclosure with the dome screw.



Wiring the Power Inputs

This device is recommended for Environment A. Use of an isolated power supply is recommended.

Follow the steps below to wire power lines from the terminal block to a compliant external DC power source.

1. Before wiring, make sure the power source is disconnected.
2. Using the wire-stripping tool, strip a short piece of insulation from the output wires of the DC power source.
3. Identify the positive and negative connection locations on the terminal block. See the symbols printed on the panel indicating the polarities and DC voltage input power range.

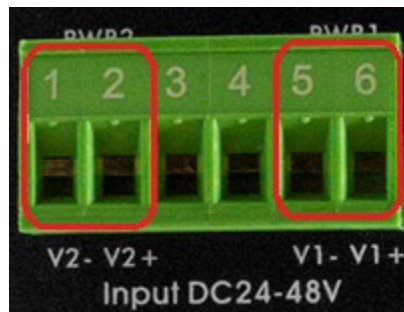

Plugs for Power 2 and Power 1

4. Insert the exposed wires into the terminal block plugs. Only wires with insulation should extend from the terminal block plugs. Note that the polarities between the wires and the terminal block plugs must be positive to positive and negative to negative.
5. Use a slotted screwdriver to tighten the captive screws.

ATTENTION: Use Copper Conductors Only. At 60-75 °C, tighten to 5 lb-in. The wire gauge for the terminal block must be in the range of **12~24 AWG**.

Note: The SI-IES-1200-LRT contains boost circuitry that will automatically step the voltage up from 24-48 to 51VDC, so you do not need to adjust input voltage above 48VDC in order to meet IEEE802.3at PoE+ spec.

The SI-IES-1200-LRT provides 51VDC with 600mA to the PD, which meets the IEEE802.3at spec. So even you have the input to the SI-IES-1200-LRT set to 48VDC, the POE port output always provides 51VDC.

RJ-45 Pin Assignments

The UTP/STP ports will automatically sense for Fast Ethernet (10Base-T/100Base-TX) or Gigabit Ethernet (10Base-T/100Base-TX/1000Base-T) connection.

Auto MDI/MDIX means that the port can connect to another switch or workstation without changing straight through or crossover cabling. See the figures below for straight through and crossover cable schema.

10/100Base-TX Pinouts

Pin Number	Assignment
1	Tx+
2	Tx-
3	Rx+
6	Rx-

Note: the “+” and “-” signs represent the polarity of the wires that make up each wire pair.

The table below shows the 10Base-T/100Base-TX MDI and MDI-X port pinouts.

Pin Number	MDI-X Signal Name	MDI Signal Name
1	Receive Data plus (RD+)	Transmit Data plus (TD+)
2	Receive Data minus (RD-)	Transmit Data minus (TD-)
3	Transmit Data plus (TD+)	Receive Data plus (RD+)
4	Transmit Data minus (TD-)	Receive Data minus (RD-)

10/100Base-TX Cable Schema

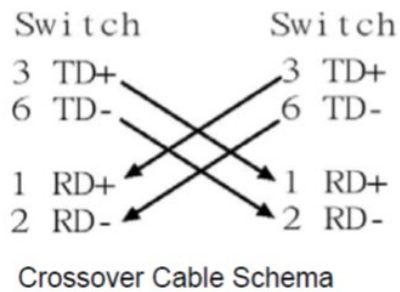
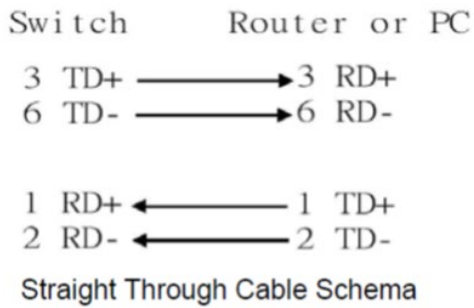

10/100/1000Base-T Pinouts

The table below describes the gigabit Ethernet RJ-45 pinouts.

Pin #	Signal Name	Description
1	BI_DA+	Bi-directional pair A+
2	BI_DA-	Bi-directional pair A-
3	BI_DB+	Bi-directional pair B+
4	BI_DC+	Bi-directional pair C+
5	BI_DC-	Bi-directional pair C-
6	BI_DB-	Bi-directional pair B-
7	BI_DD+	Bi-directional pair D+
8	BI_DD-	Bi-directional pair D-

10/100/1000Base-T Cable Schema

The following two figures illustrate the 10/100/1000Base-T cable schema.

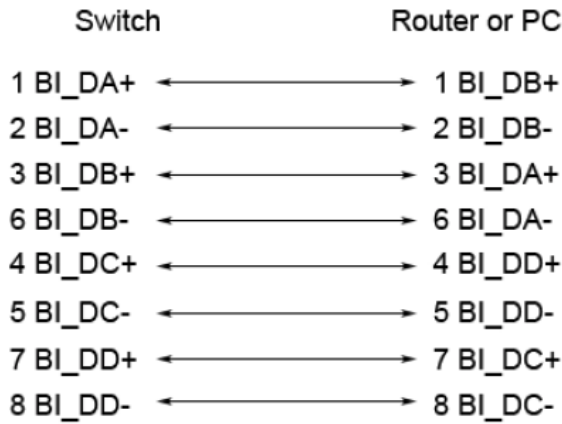

Straight Through Cable Schema

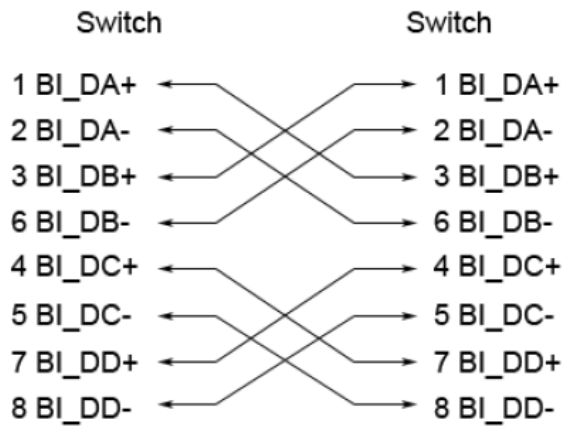

Crossover Cable Schema

Power Supply Specifications

Power supply option 25130 specs are provided below (subject to change). This power supply provides the isolation recommended for Environment A.

25130 Features and Specifications

Features

- Variable AC input range
- Protected against Overload and Over Voltage
- Convection air cooling
- DIN rail mountable
- UL 508 approved
- Full load burn in test
- RoHS Compliant
- MTBF 301.7Khrs

Specifications

Output:

- Output Voltage: 48VDC
- Current Rating: 0.83A
- Power Rating: 39.8 Watts
- Ripple & Noise Max: 200mVp-p
- Voltage Range: 48~56VDC
- Voltage Tolerance: $\pm 1.0\%$
- Line Regulation: $\pm 1.0\%$
- Load Regulation: $\pm 1.0\%$
- Setup, Rise Time: 500ms, 30ms
- Hold Up Time: 20ms/115VAC

Input:

- Voltage Range Switch Selectable: 88~264VAC, 120~370VDC
- Frequency Range: 47~63Hz
- Efficiency: 88%
- AC Current (Typical): 1.1A@115VAC, 0.7A@230VAC
- Inrush Current (Cold): 30A@115VAC, 60A@230VAC
- Leakage Current: <1mA@240VAC
- Protection Overload: 105~150%
- Overvoltage: 57.6~64.8V

Environment:

- Operating Temp: -20°C to $+70^{\circ}\text{C}$
- Storage Temp: -40°C to $+85^{\circ}\text{C}$
- Humidity: 20% to 90% (non-condensing)
- Weight: 0.66 lbs. [0.3 kg]

Compliance:

- Safety: UL508, TUV EN60950-1, NEC Class 2, LPS Compliant, UL60950-1, EN55011, EN55022,
- CISPR22, EN61204-3 Class B,
- EN61000-3-2, EN61000-3-3, EN61000-4-2,
- EN61000-4-3, EN61000-4-4, EN61000-4-5,
- EN61000-4-6, EN61000-4-8, EN61000-4-11,
- EN55024, EN61000-6-2, EN50082-2, EN61204-3 A,
- IEC60068-2-6 (Vibration)

Warranty: Lifetime



25130 Dimensions

- Width: 1.57" [40 mm]
- Depth: 3.94" [100 mm]
- Height: 3.54" [90 mm]

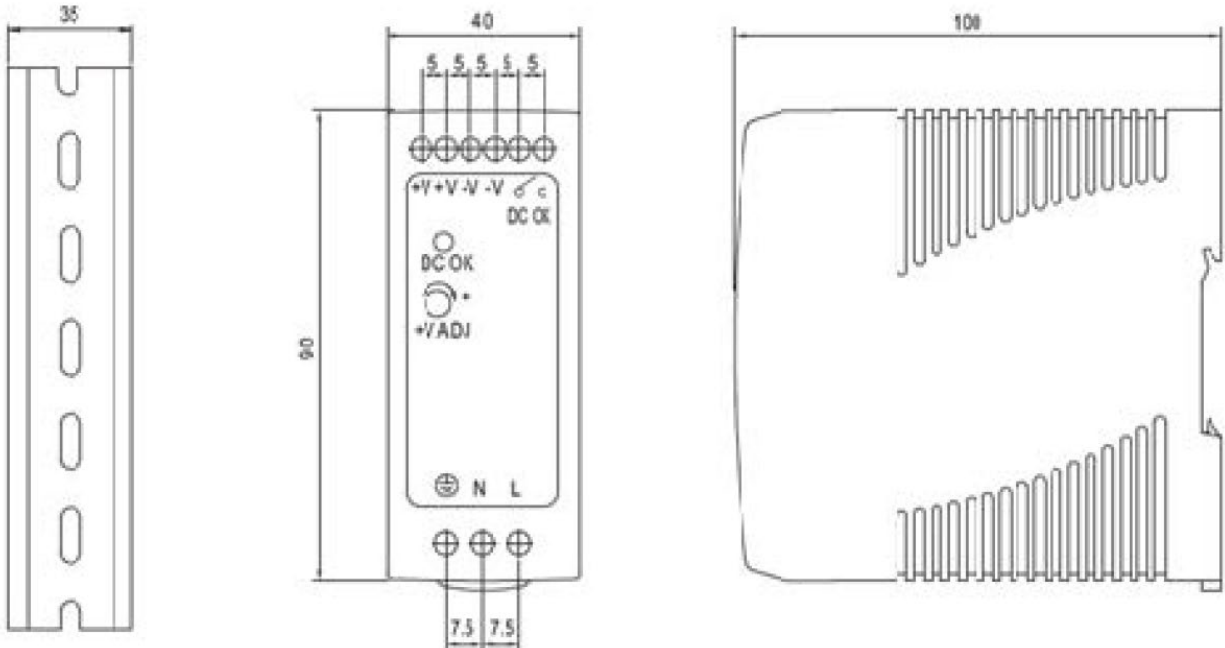

Installation

DIN-Rail Mounting

Assembling the DIN-Rail Clip

The DIN-Rail clip is screwed on the device at the factory. If not, refer to the following steps and figure to secure the DIN-Rail clip on the device.

1. Use the screws to secure the DIN-Rail clip at the rear of the device.
2. To remove the DIN-Rail clip, reverse step 1.

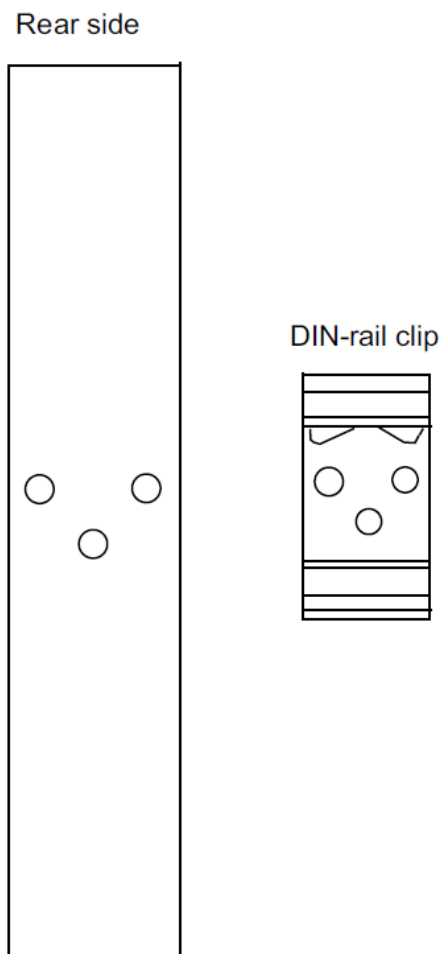

Mounting the PoE Injector (DIN-Rail)

Follow the steps below to hang the device on a standard DIN rail.

1. Position the rear side of the device directly in front of the DIN rail. Make sure the top of the clip hooks over the top of the DIN rail.

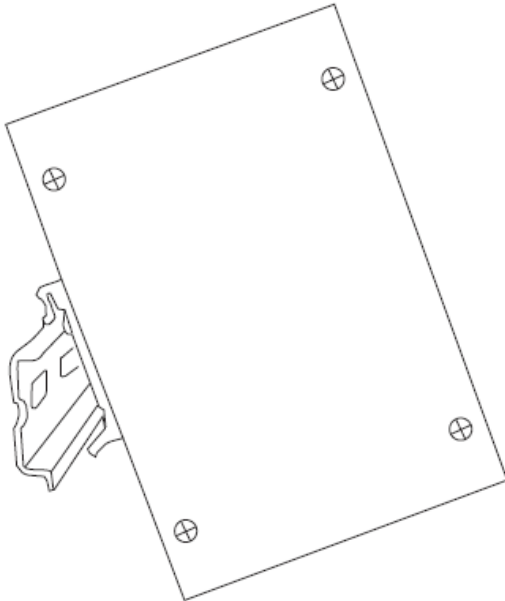

2. Push the device downward.

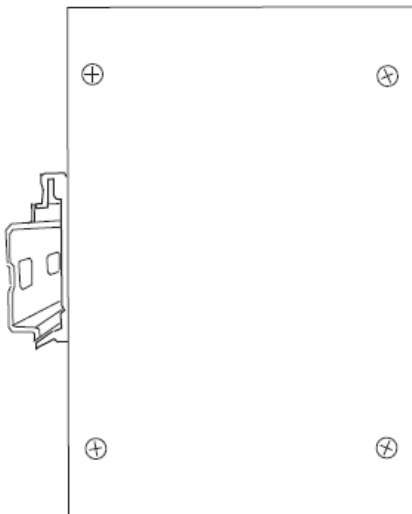

3. Check the DIN-Rail clip is tightly fixed on the DIN rail.
4. To remove the device from the track, reverse the steps above.

Wall-Mount Plate Mounting

Follow the steps below to mount the device with the wall-mount plates.

1. To remove the DIN-Rail clip from the device, unscrew the screws that secure it.
2. Align the screw holes of the wall-mount plates with the ones of the device.
3. Use the screws included to secure the wall-mount plates on the device.
4. Use the hook holes of the wall-mount plates to hang the device on the wall.
5. To remove the wall-mount plates, reverse the steps above.

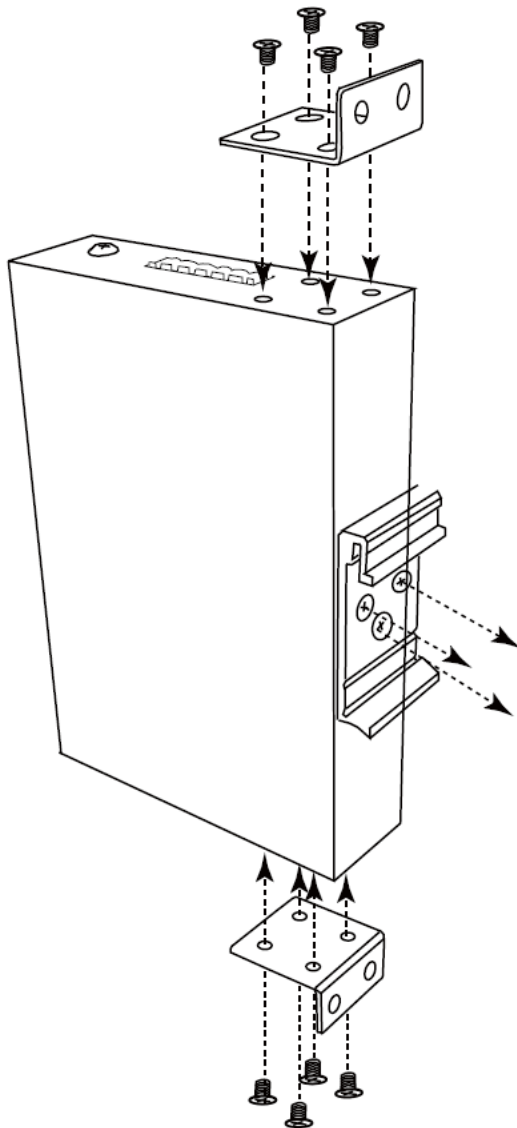

Troubleshooting

- Verify that you are using the right power cord and adapter. Do **not** use a power adapter with DC outputs higher than the power rating of this equipment, or damage will occur.
- Select the proper UTP/STP cable for your network. Please check that you are using the right cable. Use unshielded twisted-pair (UTP) or shielded twisted-pair (STP) cable for the RJ-45 connections: 100Ω Category 3, 4, or 5 cable for 10Mbps connections or 100Ω Category 5 cable for 100Mbps connections.
- Be sure that the length of any twisted-pair connection does not exceed 100 meters (328 feet).

Diagnosing LED Indicators

- The device can be easily monitored via LED indicators, which describe common problems you may encounter and where you can find possible solutions.
- If the power LED does not light when the power cord is plugged in, you may have a problem with the power cord. Check for loose power connections, power losses or surges at the power outlet. If you still cannot resolve the problem, contact your local dealer for assistance.
- If the cables are properly connected and the LEDs show normal operation, but data cannot be transmitted, check your system Ethernet devices configuration and status.

Declaration of Conformity

Model/Part Number: SI-IES-1200-LRT Industrial PoE Media Converter

Manufacture's Name: Lantronics, Inc.

Manufacture's Address: 7535 Irvine Center Drive, Suite 100, Irvine, California 92618

This declaration of conformity is issued under the sole responsibility of the manufacturer.

SI-IES-1200-LRT is in conformity with the relevant Union harmonization legislation:

EN 61000-6-4: 2007

EN 61000-6-2: 2005

And hereby is declared compliant and carries the CE marking

I, the undersigned, hereby declare that the equipment specified above conforms to the above Directive(s) and Standards(s).

Place: Irvine, California

Date: April 27, 2022

Signature: *Fathi Hakam*

Full Name: Fathi Hakam

Position: Vice President of Engineering

**Lantronix Corporate Headquarters**

7535 Irvine Center Drive
Suite100
Irvine, CA 92618, USA
Toll Free: 800-526-8766
Phone: 949-453-3990
Fax: 949-453-3995

Technical Support

Online: <https://www.lantronix.com/technical-support/>

Sales Offices

For a current list of our domestic and international sales offices, go to the Lantronix web site at www.lantronix.com/about/contact.