



ION S4110-4848 10 Gbps Fiber-to-Fiber Converter Install Guide

Part Number 33573
Revision D August 2023

Intellectual Property

© 2023 Lantronix, Inc. All rights reserved. No part of the contents of this publication may be transmitted or reproduced in any form or by any means without the written permission of Lantronix.

Lantronix is a registered trademark of Lantronix, Inc. in the United States and other countries.

All other trademarks and trade names are the property of their respective holders.

Patented: <https://www.lantronix.com/legal/patents/>; additional patents pending.

Warranty

For details on the Lantronix warranty policy, go to <http://www.lantronix.com/support/warranty>.

Contacts

Lantronix Corporate Headquarters

48 Discovery, Suite 250

Irvine, CA 92618, USA

Toll Free: 800-526-8766

Phone: 949-453-3990

Fax: 949-453-3995

Technical Support

Online: <https://www.lantronix.com/technical-support/>

Sales Offices

For a current list of our domestic and international sales offices, go to www.lantronix.com/about/contact.

Disclaimer

All information contained herein is provided "AS IS." Lantronix undertakes no obligation to update the information in this publication. Lantronix does not make, and specifically disclaims, all warranties of any kind (express, implied or otherwise) regarding title, non-infringement, fitness, quality, accuracy, completeness, usefulness, suitability or performance of the information provided herein. Lantronix shall have no liability whatsoever to any user for any damages, losses and causes of action (whether in contract or in tort or otherwise) in connection with the user's access or usage of any of the information or content contained herein. The information and specifications contained in this document are subject to change without notice.

Revision History

Rev	Date	Description of Changes
A	3/2/15	Initial release for v 1.2.4.
B	9/12/16	Update specs and contact information.
C	6/30/17	Update LPT description and remove loopback reference.
D	8/22/23	Initial Lantronix re-brand.

Contents

Introduction.....	4
Models.....	4
Accessories (ordered separately)	5
Features	5
Document Overview.....	5
Related Manuals and Online Help	5
Application Examples.....	6
Pre-Installation	7
Safety.....	7
Unpacking.....	7
Package Contents	7
DIP Switch SW1 (Function Settings).....	8
Installation and Setup.....	9
General	9
Install the S4110.....	9
Installing SFP/SFP+ Devices.....	10
SFP/SFP+ Optical Transceivers.....	10
Cabling.....	11
Power Connection	12
Operation.....	13
Power and Fiber Status LEDs	13
Establishing Link.....	13
Technical Specifications	14
Cable Specifications	15
Cable Types.....	15
Messages.....	17
Troubleshooting	18
Compliance Information	19
FCC Regulations	19
Canadian Regulations	19
European Regulations	19
Declaration of Conformity	20
Electrical Safety Warnings	21

Introduction

Lantronix two-port S4110 series is a 10 Gbps Fiber-to-Fiber Converter supporting data rates from 1G to 11.5G bps; this fiber-to fiber port converter has two SFP+ slots and performs full 3R (re-amplify, re-shape, and re-timing) signal regeneration. It can be used all alone or it can be connected to another x4110, providing fiber-to-fiber conversion in the following user networks:

- 10G LAN, 10G WAN
- 10G Fiber Channel
- SONET OC192
- 10G OTN (G.709)

The S4110 can be used in telecom and enterprise applications where 10 Gbps links require fiber extension or where 10 Gbps links require an interface between two different types of fiber. The S4110 performs a wide variety of protocol transparent service; it supports virtually any protocol from 1 Gbps to 11.5 Gbps:

- 10G LAN (10.3125 Gbps) / WAN (9.95 Gbps)
- SONET OC-192/SDH STM-64 at 9.95 Gbps
- 10G Fiber Channel at 10.52 Gbps
- 1/2/4/8 Gbps Fiber channel
- OTU2 at 10.709 Gbps
- OTU1e at 11.05 Gbps
- OTU1f at 11.27 Gbps
- OTU2e at 11.09 Gbps
- OTU2f at 11.32 Gbps
- SONET OC-48/SDH STM-16 at 2.40 Gbps
- Legacy 1G Ethernet at 1.25 Gbps
- Any other rate from 1 - 11.5 Gbps

Models

The S4110 is an ION Stand-alone device. The C4110 is an ION chassis slide-in-card.

The S4110 is used as remote device when linked back to a managed chassis card.

The C4110 SIC card can be managed by ION Web or ION CLI. The S4110 can not be remotely managed.

Manageable C4110 features are available when used in an ION Platform chassis along with an ION Management Module (IONMM). The x4110 is delivered with a default configuration. You can change the configuration via the ION Web interface and the ION CLI.

Model	Fiber Connections	Rates
S4110-4848	SFP/SFP+	1-11.5Gbps
C4110-4848	SFP/SFP+	1-11.5Gbps

Accessories (ordered separately)

The S4110 Power Supply is included. To order the corresponding country-specific power supply, add the extension to the end of the SKU (e.g., S4110-4848-NA). The Country Codes are -NA = North America, -LA = Latin America, -EU = Europe, -UK = United Kingdom, -SA = South America, -JP = Japan, -OZ = Australia, and -BR = Brazil.

Model	Description
WMBL	4" [102 mm] Wall Mount Kit (long). Fits Stand-Alone Converters and ION.
WMBD	5" [127 mm] DIN Rail Mount Bracket fits all stand-alone converters and single or dual slot ION chassis.
E-MCR-05	12-Slot Media Converter Rack
RMS19-SA4-01	4-Slot Media Converter Shelf
SFP Modules	SFP and SFP+ modules supported. See the Lantronix SFP webpage .

Features

- Supports various physical media types
- Fiber repeater, performs 3R signal regeneration
- Auto link restore
- No packet size limitation

Document Overview

The purpose of this manual is to provide the information needed to install the S4110 to the point of operation. Note that there is a separate install guide for the C4110.

Related Manuals and Online Help

A printed documentation card is shipped with each S4110 device. A substantial set of technical documents, white papers, case studies, etc. are available on the Lantronix web site at <https://www.lantronix.com/technical-support/>. Note that this manual provides links to third party web sites for which Lantronix is not responsible. Other ION system and related device manuals include:

1. Product Documentation Postcard, 33504
2. ION C4110 Install Guide, 33572
3. ION S4110 Install Guide, 33573 (this manual)
4. ION x4110 Web User Guide, 33574
5. ION x4110 CLI Reference, 33575
6. ION Management Module (IONMM) Install Guide, 33420 and User Guide, 33457
7. Release Notes (firmware version specific)

Note: Information in this document is subject to change without notice. All information was deemed accurate and complete at the time of publication. This manual documents the latest software/firmware version. While all screen examples may not display the latest version number, all of the descriptions and procedures reflect the latest software/firmware version, noted in the [Revision History](#) on page 2.

Note: Some Documentation may have Transition Networks named or pictured. Transition Networks was acquired by Lantronix in August 2021.

Application Examples

The S4110 provides up to 10Gig fiber-to-fiber port repeating and performs full 3R (re-amplify, re-shape and re-timing) signal regeneration. The figures below show how x4110 devices can be used in pairs (scenarios A,B,C below) or used as single repeater in a customer network (scenarios D & E below); It can also interconnect with an x4110-1048 (scenario F).

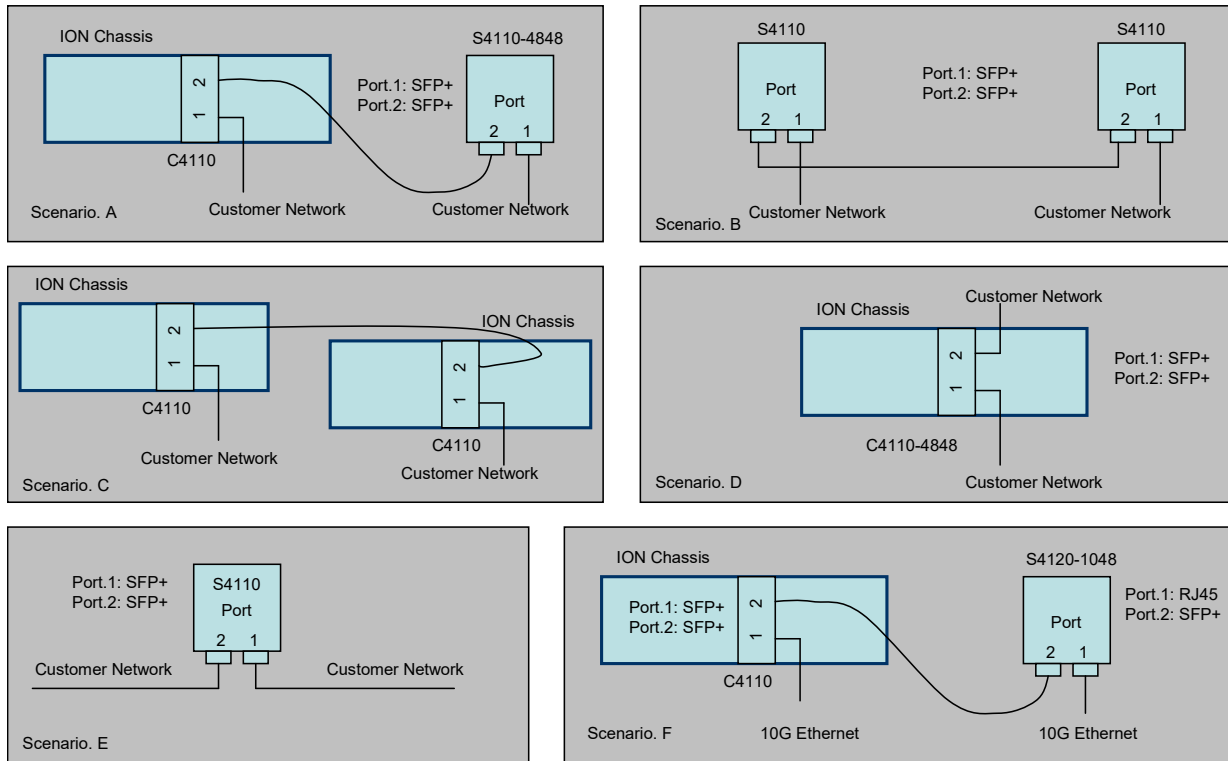

Figure 1: Network Scenarios

Pre-Installation

CAUTION: Observe electrostatic discharge precautions when handling the S4110. Failure to observe this caution could result in damage or failure of the S4110.

Safety

Before installing the S4110, read the “Safety Cautions” and ensure that the requirements noted are met. During installation and maintenance, avoid direct exposure to laser beams. Specifically, do not look into laser ports. Ensure that each SFP/SFP+ port at which laser beams are (or will be) present is occupied by an SFP/SFP+ that is locked in position. See the related SFP/SFP+ manual for details.

See "[Electrical Safety Warnings](#)" on page 21 for Electrical Safety Warnings translated into multiple languages.

Unpacking

1. Carefully unpack all S4110 contents.
2. Verify receipt of all S4110 components; see “[Package Contents](#)” below.
3. Place the S4110 and related materials in the desired install location.
4. Save the S4110 shipping carton and packing materials for future use.

Package Contents

The S4110 is shipped with some standard and some optional components. Make sure you have received the following standard items:

- One S4110 device
- One AC Power Cord/Adapter
- One printed Product Documentation postcard
- Four Rubber feet

DIP Switch SW1 (Function Settings)

The 8-position DIP switch is labeled CONFIG SWITCHES on the right side of the S4110 enclosure. The factory default setting is SW1 – 8 in the **ON** position (Down). SW5 - 8 settings are not used ('do not care'). Use a small, flat-blade screwdriver (or similar tool) to set the DIP switches to site requirements.

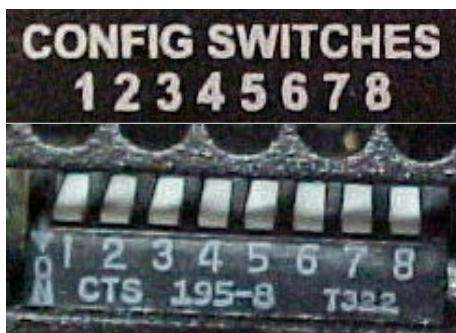

Note 1: Component labeling may vary; the figure above shows SW 1-8 in the position labeled '**ON**' (Down).

Table 1: DIP Switch SW1 Settings

1	2	3	4	Data Rate
Down	Down	Down	Down	10GE = 10 gigabit Ethernet (also 10GbE or 10 GigE). This is the factory default setting.
Up	Down	Down	Down	10GFC + FEC = 10GbE Fibre Channel with Forward Error Correction.
Down	Up	Down	Down	10GFC = 10GbE Fibre Channel.
Up	Up	Down	Down	WAN/OC-192+FEC = OC-192 network line with transmission speeds up to 9953.28 Mbit/s with Forward Error Correction.
Down	Down	Up	Down	WAN/OC-192 = OC-192 network line with transmission speeds up to 9953.28 Mbit/s.
Up	Down	Up	Down	8GFC = 8G Fiber Channel with 8.5 gigabaud Line rate and 1,600 MBps Throughput (at full duplex).
Down	Up	Up	Down	4GFC = 4G Fiber Channel with 4.25 gigabaud Line rate and 800 MBps Throughput (at full duplex).
Up	Up	Up	Down	2GFC = 2G Fiber Channel with 2.125 gigabaud Line rate and 400 MBps Throughput (at full duplex).
Down	Down	Down	Up	1GFC = 1GbE Fibre Channel.
Up	Down	Down	Up	2.5G = 2.5 gigabit Ethernet.
Down	Up	Down	Up	1GE = 1 gigabit Ethernet.
Up	Up	Down	Up	OC-48 = network line with transmission speeds of up to 2488.32 Mbit/s.
Down	Down	Up	Up	Reserved (Default).
Up	Down	Up	Up	Reserved (Default).
Down	Up	Up	Up	Reserved (Default).
Up	Up	Up	Up	Reserved (Default).

Installation and Setup

General

This section describes how to install the S4110 and the procedures to access and initially set it up via either a local serial interface (USB) or a remote Ethernet connection (Telnet session or Web interface).

Install the S4110

The S4110 is a standalone module that can be deployed on its own or it can be connected to a C4110 ION Chassis card installed in a Lantronix ION chassis (ION106 and ION219).

The following section describes how to install the S4110.



Caution: Failure to observe electrostatic discharge precautions when installing the S4110 could result in damage or failure of the module.

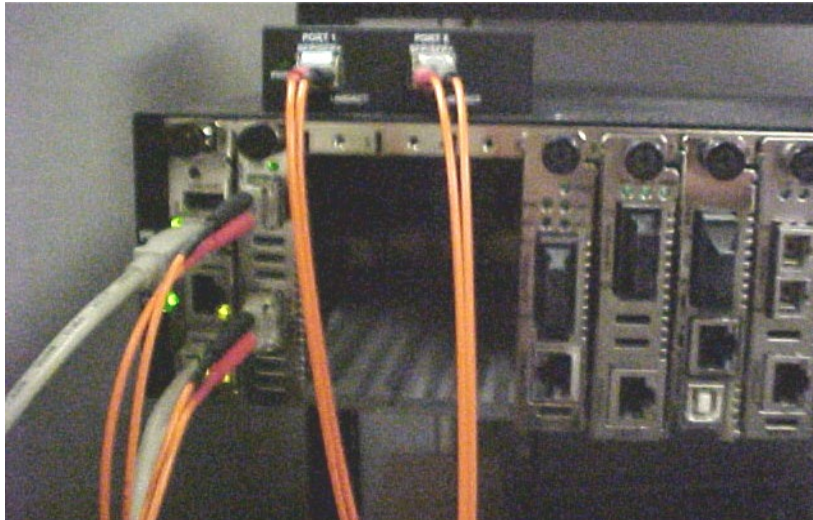

Figure 2: Installation

1. Place the S4110 in its final install location.
2. Install SFP or SFP+ Devices in PORT 1 and PORT 2. See “[Installing SFP/SFP+ Devices](#)” below.
3. Perform cabling to the S4110. See the “[Cabling](#)” section on page 11.
4. Make the Power Connection. See the “[Power Connection](#)” section on page 12.
5. Note that the card’s Power LED lights. See “[Power and Fiber Status LEDs](#)” on page 13.

Installing SFP/SFP+ Devices

The C4110 lets you install SFP/SFP+ devices of choice to make a fiber connection. The C4110 has two SFP/SFP+ ports. The C4110 has two ports. The locations of PORT1 and PORT 2 (SFP/SFP+) are shown below. **Note:** The S4100 is an “any rate to same rate” device, meaning the two SFPs used must both support the same data rate. However, two SFPs can support different types of fiber and different transmission distances.

SFP/SFP+ Optical Transceivers

Lantronix SFP and SFP+ devices are small form factor, hot-pluggable transceivers which allow for a single piece of network equipment to be connected to a multitude of interfaces, protocols, and transmission media via the SFP/SFP+ port. All of Transition’s SFPs and SFP+ devices are compliant with the Multi-Sourcing Agreement (MSA) ensuring interoperability with all other MSA compliant networking devices.

The SFP/SFP+ module used defines the fiber length and type that can be supported. Identical SFP/SFP+ modules must be used at each end of the fiber link for each port on this device.

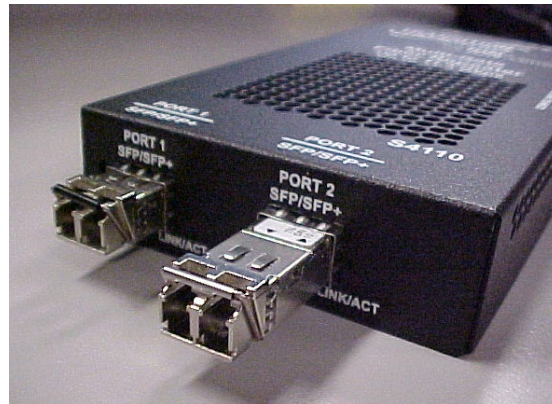

Figure 3: Port Locations and SFP/SFP+ Installation

To install an SFP/SFP+ device in the C4110:

1. Position the SFP/SFP+ device at either installation slot, with the label facing up.
2. Carefully slide the SFP/SFP+ device into the slot, aligning it with the internal installation guides.
3. Ensure that the SFP/SFP+ device is firmly seated against the internal mating connector.
4. Connect the fiber cable to the fiber port connector of the SFP/SFP+ device.

See the [SFP webpage](#) for the latest SFP information.

Cabling

The C4110 can be used in telecom and enterprise applications where links supporting data rates from 1Gig to 10Gig require fiber extension or where 10Gig links require an interface between two fiber networks. It performs 3R (re-amplify, re-shape, re-time) signal regeneration. The S4110 is protocol 'agnostic', supporting a wide variety of protocols in a network; from 1 to 11.5Gbps, including 10G LAN, 10G WAN, 10G Fiber Channel, SONET OC192, 10G OTN (G.709), 1/2/4/8 Gig Fiber Channel, 1 Gig Ethernet, or Sonet OC-48. The fiber length and type is defined by the SFP+ module inserted.

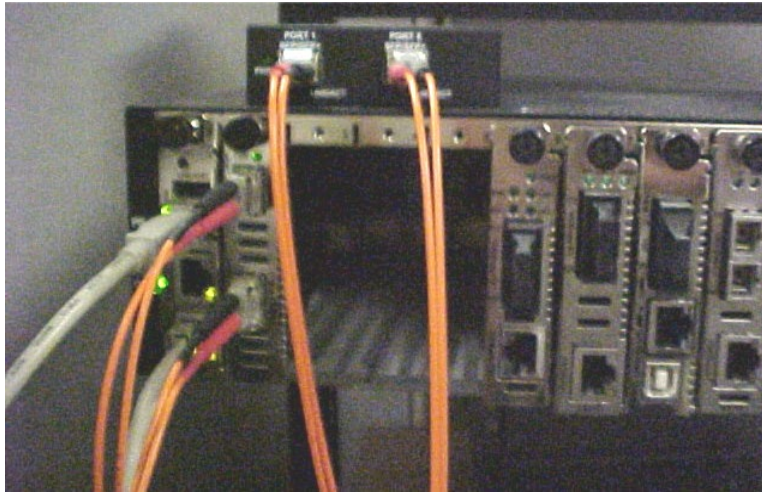

Figure 4: C4110-to-S4110 Connection

The figure above shows cabling a C4110 to an S4110. The S4110 cabling procedure is provided below.

1. Locate a fiber cable with male, two-stranded TX to RX connectors installed at both ends. See “[Cable Specifications](#)” on page 15 for details.
2. Connect the fiber cable to the 10GE SFP+ fiber port (Port 2 labeled **10GE SFP+**) on the C4110:
 - Connect the male TX cable connector to the female TX connector.
 - Connect the male RX cable connector to the female RX connector.
3. Connect the fiber cables to the 10GE fiber port on the other device per the device requirements.

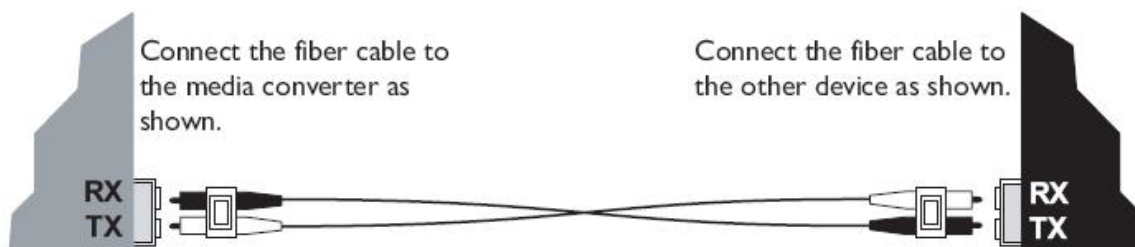

Figure 5: Fiber Connection

Power Connection

The S4110 ships with a power supply module that provides power via a barrel connector to the S4110 power receptacle.



Figure 6: Power Connection

Make the power connection as described below.

1. Plug the power supply's barrel connector into the standalone module See the figure below.
2. Plug the power supply's cord into a live AC power outlet.
3. Verify that the green **PWR** (Power) LED lights.

Operation

Power and Fiber Status LEDs

Status LEDs (**PWR** and **LINK**) are used to monitor S4110 operation in the network.

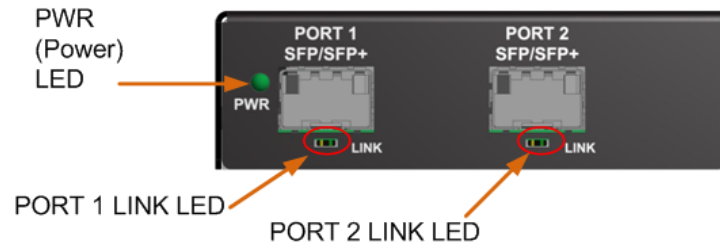

Figure 7: Power and Fiber Status LEDs

The Power and Fiber Status LEDs are described below.

LED Label	Meaning	Operation
PWR	Power	Green ON for power applied to board.
PORT 1 LINK	Fiber Status 1	On = Fiber Signal Detected. Off = Fiber Signal Not Detected.
PORT 2 LINK	Fiber Status 2	On = Fiber Signal Detected. Off = Fiber Signal Not Detected.

Establishing Link

The Link LEDs on end devices (10Gig switches) do not light until an end-to-end link is established, as shown in Figure 8 below. If you only connect one port on the x4110 to an end device, the link LED on the media converter will not light with most SFPs, and you will not see link on the end device. While this may kind of look like a Link Pass Through Event, the S4110 does not support LPT. After both links are connected, the Link LEDs will light on the end devices.

10Gig switches link when RS-to-RS layers can communicate. They need to see RS-to-RS to establish link. The RS (Reconciliation Sub-layer) works at layer-4, the Transport layer. Lantronix' media converters do not link at the RS Layer; therefore the LEDs at the end device will not light. So with the S4110, you must make all connections before the port status LEDs light.



Figure 8: Establishing Link

Technical Specifications

Standards:	IEEE802.3ae / ITU.G.709 / SFF8431
Data Rate	10 Gbps
Dimensions	Width: 0.86" [21.85 mm] Depth: 6.5" [165 mm] Height: 3.4" [86.36 mm]
Power Source	External AC/DC power supply Supplied AC Power Cord/Adapter
Power Consumption	4.2W (350mA @12V)
Operating Temperature	0 to + 50 degrees C
Storage Temperature	-40 to + 85 degrees C
Altitude	0-10,000 feet
Operating Humidity	5% to 95% (non-condensing)
Shipping Weight	2 lbs. (0.90 Kg.)
MTBF with Power Supply:	Greater than 41,660 hours (MIL-HDBK-217F) Greater than 114,580 hours (Bellcore)
MTBF without Power Supply:	Greater than 250,000 hours (MIL-HDBK-217F) Greater than 687,000 hours (Bellcore)
Regulatory Compliance for:	
Emission	FCC Class A; EN55022 Class A
Immunity	EN55024
Safety Compliance	CE Mark
Warranty:	Lifetime

The information in this user's guide is subject to change. For the latest information, see the online user's guide at: <https://www.lantronix.com/products/s4110-4848-2/>.

WARNING: Visible and invisible laser radiation when open. DO NOT stare into the beam or view the beam directly with optical instruments. Failure to observe this warning could result in an eye injury or blindness.

WARNING: Use of controls, adjustments or the performance of procedures other than those specified herein may result in hazardous radiation exposure.

Cable Specifications

The physical characteristics must meet or exceed IEEE 802.3™ specifications.

Fiber port: SFP+, both Class-I and Class-II, 10.3125Gbps.

Cable Types

The cabling specifications are provided for reference and troubleshooting purposes.

Fiber (10GbE) Cabling

The two general types of fiber optic cables are SMF (single-mode fiber) and MMF (multi-mode fiber).

SMF has an optical core of approximately 9 µm (microns), and has lower modal dispersion than MMF, and can support distances of at least 10 Km and as high as 80-100 Km (Kilometers) or more, depending on transmission speed, transceivers, etc..

MMF has an optical core of either 50 µm or 62.5 µm, and it supports distances up to 600 meters, depending on transmission speeds and transceivers.

Table 2: Fiber Cable Descriptions

Standard	Cable Type	Core Diameter	IEEE Standard Distance	Wavelength
OM1	Multi-mode (MMF)	62.5/125 µm	33 meters (SR)	850 / 1300 nm
OM2	Multi-mode (MMF)	50/125 µm	82 meters (SR)	850 / 1300 nm
OM3	Multi-mode (MMF)	50/125 µm	300 meters (SR)	850 / 1300 nm
OM4	Multi-mode (MMF)	50/125 µm	550 meters (SR)	850 / 1300 nm
OS1	Single mode (SMF)	9 µm	up to 10,000m	1310 / 1550 nm

OS1 SMF optics are used for distances up to 10,000m (6.2 miles) with standard transceivers and can work at longer distances with special transceivers and switching infrastructure.

The C4110 supports:

10GBase-SR: The most common type of fiber-optic 10GbE cable that supports an SFP+ connector with an optical transceiver rated for 10Gb transmission speed (also known as “short reach” fiber-optic cables).

10GBase-LR: The the “long reach” fiber optic cables that support single-mode fiber optic cables and connectors. Provides serialized data at a line rate of 10.3125 Gbit/s. 10GBASE-LR has a specified reach of 10 kilometres (6.2 mi), but 10GBASE-LR optical modules can often manage distances of up to 25 kilometres (16 mi) with no data loss.

10GBase-ER: The "extended reach" port type for single-mode fiber that uses 1550 nm lasers. Its Physical Coding Sublayer 64b/66b PCS is defined in IEEE 802.3 Clause 49 and its Physical Medium Dependent PMD in Clause 52. It delivers serialized data at a line rate of 10.3125 Gbit/s.

10GBase-ZR: An 80 km (50 mile) range ER pluggable interface, the 80 km PHY is not specified within the IEEE 802.3ae standard, and manufacturers have created their own specifications based on the 80 km PHY described in the OC-192/STM-64 SDH/SONET specifications.

Note: the interface standard used is defined by the fiber module used and is transparent to the x4110. All other standards are limiting mode (EDC disabled).

Note: the S4110 does not support 10GBase-LX4, 10GBase-CX4, or 10GBase-LRM.

Optical Transport Network (OTN)

The Optical Transport Hierarchy (OTH) is a new transport technology for the Optical Transport Network (OTN) developed by the ITU. OTH is based on the network architecture defined in ITU G.872 "Architecture for the Optical Transport Network (OTN)".

G.872 defines an architecture that is composed of the Optical Channel (OCh), Optical Multiplex Section (OMS) and Optical Transmission Section (OTS). G.872 then describes the functionality that needed to make OTN work.

Compared to SONET/SDH, using OTN offers advantages (stronger Forward Error Correction, more levels of TCM, transparent transport of Client signals, switching scalability) and disadvantages (requires new hardware and management system).

OTU Type	OTU Bit Rate (Nominal)
OTU1	255/238 x 2 488 320 kbit/s
OTU2	255/237 x 9 953 280 kbit/s
OTU3	255/236 x 39 813 120 kbit/s

The OTU bit rate tolerance is ± 20 ppm for OTU1, OTU2, and OTU3. The nominal OTUk rates are approximately 2 666 057.143 kbit/s (OTU1), 10 709 225.316 kbit/s (OTU2) and 43 018 413.559 kbit/s (OTU3).

See <http://www.itu.int/rec/T-REC-G.709/> for more information.

Fibre Channel (FC)

FC (Fibre Channel) is a high-speed network technology (common rates of 2-, 4-, 8- and 16-Gbps) often used to connect computer data storage. Fibre Channel is standardized in the T11 Technical Committee of [INCITS](#) (the International Committee for Information Technology Standards) an ANSI standards committee.

Note: When FC technology was developed, it supported only optical cabling (fiber). Copper cable support was later added, so the development committee kept the same name but changed to the British spelling 'fibre' for the standard. The American English spelling 'fiber' refers only to optical cabling, so a network using 'fibre' can be implemented either with copper or optical cabling.

The FC protocol has a range of speeds based on a various underlying transport media. Native FC speed variants include:

Media	Line-rate (GBps)	Throughput (full duplex; Mbps)*	Availability
1GFC	1.0625	200	1997
2GFC	2.125	400	2001
4GFC	4.25	800	2004
8GFC	8.5	1,600	2005
10GFC	10.52	2,550	2008

Fibre Channel does not follow OSI Layer modeling, but is similarly split into five layers (FC0 - FC4):

FC4: Protocol-mapping layer, in which application protocols, such as SCSI or IP, are encapsulated into a PDU for delivery to FC2.

FC3: Common services layer, a thin layer that could eventually implement functions like encryption or RAID redundancy algorithms.

SONET (Synchronous Optical Transport Network)

Synchronous Optical Network, a standard for connecting fiber-optic transmission systems. SONET was proposed by Bellcore in the middle 1980s and is now an ANSI standard.

SONET defines interface standards at the physical layer of the OSI seven-layer model. The standard defines a hierarchy of interface rates that allow data streams at different rates to be multiplexed. SONET establishes Optical Carrier (OC) levels from 51.8 Mbps (OC-1) to 9.95 Gbps (OC-192). The international equivalent of SONET, standardized by the ITU, is called SDH.

SONET and Synchronous Digital Hierarchy (SDH) are standardized protocols that transfer multiple digital bit streams synchronously over optical fiber using lasers or highly coherent light from light-emitting diodes (LEDs). At low transmission rates data can also be transferred via an electrical interface. The method was developed to replace the Plesiochronous Digital Hierarchy (PDH) system for transporting large amounts of telephone calls and data traffic over the same fiber without synchronization problems. SONET generic criteria are detailed in Telcordia Technologies Generic Requirements document GR-253-CORE.

Both SDH and SONET are widely used today: SONET in the United States and Canada, and SDH in the rest of the world. Although the SONET standards were developed before SDH, it is considered a variation of SDH because of SDH's greater worldwide market share. SONET and SDH often use different terms to describe identical features or functions. This can cause confusion and exaggerate their differences. With a few exceptions, SDH can be thought of as a superset of SONET.

Messages

Message: *Setting values failed (snmp operation error, possible reasons: invalid data, error data sequence, etc)*

Meaning: The selected parameter setting was not recognized.

Recovery: Click the Refresh button to clear the error message.

Message: *The DMI feature is not supported on current port.*

Meaning: Either the port or the SFP does not support DMI, or an SFP is not currently installed in Port 1.

Recovery: Either insert an SFP/SFP+ in Port 1, or change to Port 1, or change SFPs to a type that supports DMI. See notes above for SFP DMI support.

Troubleshooting

If a problem or exception occurs, the S4110 will send a related Trap message to the Trap Server to report this event.

1. Is the **PWR** (power) LED lit?
NO
 - Is the C4110 inserted properly into the chassis?
 - Is the power cord properly connected to the C4110 chassis and plugged into a live grounded AC outlet?
 - Does the grounded AC outlet provide power?
 - Contact Tech Support.YES
 - Proceed to step 2.
2. Is the **LINK** LED lit?
NO
 - Check that the SFP+ device is supported and properly connected. See “[Installing SFP/SFP+ Devices](#)” on page 10.
 - Check the fiber cables for proper connection.
 - Verify that the cable specs are met. See “[Cable Specifications](#)” on page 15.
 - Contact Tech Support.YES
 - Proceed to step 3.
3. Is the CLI accessible?
NO
 - Check the Install process. See “[Installation and Setup](#)” on page 9.
 - Check the cabling. See “[Cabling](#)” on page 11.
 - Contact Tech Support.YES
 - Proceed to step 4.
4. Is the web GUI accessible?
NO
 - Check the Install process. See “[Installation and Setup](#)” on page 9.
 - Check the cabling. See “[Cable Specifications](#)” on page 15.Yes
5. Does a message display indicating that the S4110 is not discovered by the connected device?
 - Verify that the SFP/SFP+ devices at each end are identical.
6. Does the Data Rate Retiming setting match the SFP/SFP+ device being used?
No
 - Change the Data Rate Retiming setting or change the type of SFP/SFP+ device so they match.Yes
 - Contact Tech Support.

Compliance Information

FCC Regulations

This equipment has been tested and found to comply with the limits for a Class A digital device, pursuant to part 15 of the FCC rules. These limits are designed to provide reasonable protection against harmful interference when the equipment is operated in a commercial environment. This equipment generates, uses, and can radiate radio frequency energy and, if not installed and used in accordance with the instruction manual, may cause harmful interference to radio communications.

Operation of this equipment in a residential area is likely to cause harmful interference, in which case the user will be required to correct the interference at the user's own expense.

Canadian Regulations

This digital apparatus does not exceed the Class A limits for radio noise for digital apparatus set out on the radio interference regulations of the Canadian Department of Communications.

Le présent appareil numérique n'émet pas de bruits radioélectriques dépassant les limites applicables aux appareils numériques de la lass A prescrites dans le Règlement sur le brouillage radioélectrique édicté par le ministère des Communications du Canada.

European Regulations

Warning

This is a Class A product. In a domestic environment this product may cause radio interference in which case the user may be required to take adequate measures.

Achtung !

Dieses ist ein Gerät der Funkstörgrenzwertklasse A. In Wohnbereichen können bei Betrieb dieses Gerätes Rundfunkstörungen auftreten. In diesem Fall ist der Benutzer für Gegenmaßnahmen verantwortlich.

Attention !

Ceci est un produit de Classe A. Dans un environnement domestique, ce produit risque de créer des interférences radioélectriques, il appartiendra alors à l'utilisateur de prendre les mesures spécifiques appropriées.



In accordance with European Union Directive 2002/96/EC of the European Parliament and of the Council of 27 January 2003, Lantronix will accept post usage returns of this product for proper disposal. The contact information for this activity can be found in the 'Contact Us' portion of this document.

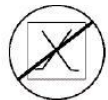

CAUTION: RJ connectors are NOT INTENDED FOR CONNECTION TO THE PUBLIC TELEPHONE NETWORK. Failure to observe this caution could result in damage to the public telephone network.

Der Anschluss dieses Gerätes an ein öffentliches Telekommunikationsnetz in den EGMitgliedstaaten verstösst gegen die jeweiligen einzelstaatlichen Gesetze zur Anwendung der Richtlinie 91/263/EWG zur Angleichung der Rechtsvorschriften der Mitgliedstaaten über Telekommunikationsendeinrichtungen einschliesslich der gegenseitigen Anerkennung ihrer

Declaration of Conformity

Manufacture's Name: Lantronics, Inc.

Manufacture's Address: 48 Discovery, Suite 250, Irvine, California 92618 USA

Declares that the products:

C4110, S4110

Conforms to the following Product Regulations:

FCC Part 15 Class A, EN 55032:2012, EN 55024:2010

Directive 2014/30/EU, Directive 2015/863/EU

Low-Voltage Directive 2014/35/EU

IEC /EN 60950-1:2006+A2:2013

2011/65/EU EN 50581:2012

With the technical construction on file at the above address, this product carries the CE Mark

I, the undersigned, hereby declare that the equipment specified above conforms to the above Directive(s) and Standard(s).

Place: Irvine, California

Date: August 18, 2023

Signature: **Eric Bass**

Full Name: Eric Bass

Position: Vice President of Engineering

Electrical Safety Warnings

Electrical Safety

IMPORTANT: This equipment must be installed in accordance with safety precautions.

Elektrische Sicherheit

WICHTIG: Für die Installation dieses Gerätes ist die Einhaltung von Sicherheitsvorkehrungen erforderlich.

Elektrisk sikkerhed

VIGTIGT: Dette udstyr skal 21nstillers I overensstemmelse med sikkerhedsadvarslerne.

Elektrische veiligheid

BELANGRIJK: Dit apparaat moet in overeenstemming met de veiligheidsvoorschriften worden geïnstalleerd.

Sécurité électrique

IMPORTANT : Cet équipement doit être utilisé conformément aux instructions de sécurité.

Sähköturvallisuus

TÄRKEÄÄ : Tämä laite on asennettava turvaohjeiden mukaisesti.

Sicurezza elettrica

IMPORTANTE: questa apparecchiatura deve essere installata rispettando le norme di sicurezza.

Elektrisk sikkerhet

VIKTIG: Dette utstyret skal 21nstillers I samsvar med sikkerhetsregler.

Segurança eléctrica

IMPORTANTE: Este equipamento tem que ser instalado segundo as medidas de precaução de segurança.

Seguridad eléctrica

IMPORTANTE: La instalación de este equipo deberá llevarse a cabo cumpliendo con las precauciones de seguridad.

Elsäkerhet

OBS! Alla nödvändiga försiktighetsåtgärder måste vidtas när denna utrustning används

**Lantronix Corporate Headquarters**

48 Discovery, Suite 250
Irvine, CA 92618, USA
Toll Free: 800-526-8766
Phone: 949-453-3990
Fax: 949-453-3995

Technical Support

Online: <https://www.lantronix.com/technical-support/>

Sales Offices

For a current list of our domestic and international sales offices, go to the Lantronix web site at www.lantronix.com/about/contact.