



S4120-1048
10GBASE-T to 10G Fiber Media Converter
Install Guide

Part Number 33550
Revision E March 2024

Intellectual Property

© 2023-2024 Lantronix, Inc. All rights reserved. No part of the contents of this publication may be transmitted or reproduced in any form or by any means without the written permission of Lantronix.

Lantronix is a registered trademark of Lantronix, Inc. in the United States and other countries. All other trademarks and trade names are the property of their respective holders.

Patented: <https://www.lantronix.com/legal/patents/>; additional patents pending.

Warranty

For details on the Lantronix warranty policy, go to <http://www.lantronix.com/support/warranty>.

Contacts

Lantronix Corporate Headquarters

48 Discovery, Suite 250
Irvine, CA 92618, USA
Toll Free: 800-526-8766
Phone: 949-453-3990
Fax: 949-453-3995

Technical Support

Online: <https://www.lantronix.com/technical-support/>

Sales Offices

For a current list of our domestic and international sales offices, go to www.lantronix.com/about/contact.

Disclaimer

All information contained herein is provided "AS IS." Lantronix undertakes no obligation to update the information in this publication. Lantronix does not make, and specifically disclaims, all warranties of any kind (express, implied, or otherwise) regarding title, non-infringement, fitness, quality, accuracy, completeness, usefulness, suitability, or performance of the information provided herein. Lantronix shall have no liability whatsoever to any user for any damages, losses and causes of action (whether in contract or in tort or otherwise) in connection with the user's access or usage of any of the information or content contained herein. The information and specifications contained in this document are subject to change without notice.

Revision History

Rev	Date	Description
A	07/15/13	Initial release for v 1.2.3.
B	6/8/18	Update to FW v 2.0.1, DoC and contact info.
C	9/25/20	Update port layout graphics. and add power supply information
D	8/21/23	Initial Lantronix re-brand.
E	3/29/24	Correct the Model # from x4120-1040 to x4120-1048.

Contents

Introduction.....	4
Document Overview.....	4
Related Manuals and Online Help	4
Models.....	5
Features	5
Ethernet PHY Interfaces	5
Standards.....	5
10-Gigabit Ethernet Standards	5
10-Gigabit Ethernet Fiber Port.....	6
10-Gigabit Ethernet Optical Fiber	6
10-Gigabit Ethernet Copper Port	6
Category 6a Cable.....	6
Application Examples.....	7
Product Features	8
For More Information	11
Installation	12
4-Position DIP Switch	12
Hardware/Software Mode Jumper (J8).....	12
Installing SFP+ Devices.....	13
SFP/XFP Optical Transceivers	14
Cabling.....	14
Install Fiber and Copper Cable	15
IONMM Installation	15
Operation.....	16
Status LEDs	16
Cable Specifications.....	16
Copper Cable.....	17
Cable Types.....	17
Technical Specifications.....	22
Troubleshooting	23
Compliance Information	24
Declaration of Conformity	24
FCC Regulations	24
Canadian Regulations	24
European Regulations	25

Introduction

The x4120-1048 is a 10 Gigabit Ethernet copper to fiber media converter. It offers conversion technology by providing one 10GBase-T RJ-45 port and one pluggable 10GBase-X fiber SFP+ port. The open SFP+ port supports a wide variety of Lantronix 10GE SFP+ fiber modules, as well as third party MSA compatible SFP+ modules.

The x4120 provides several 10G Ethernet enterprise and data center connectivity solutions. Since most 10G Ethernet switches support a combination of copper RJ-45 and open SFP+ ports, the x4120 allows users to convert either of these ports to the media type of their preference to match their network requirements.

The stand-alone S4120 is an unmanaged device, until it is linked to C4120 installed in a managed ION chassis, and then remote in-band management of the S4120 is available.

Document Overview

The purpose of this manual is to provide the information needed to install the S4120 to the point of operation. Note that there is a separate install guide for the C4120.

Related Manuals and Online Help

A printed documentation card is shipped with each x4120 device. Context-sensitive Help screens, as well as cursor-over-help (COH) facilities are built into the Web interface. A substantial set of technical documents, white papers, case studies, etc. are available on the Lantronix web site at <http://www.lantronix.com/>. Note that this manual provides links to third party web sites for which Lantronix is not responsible. Other ION system and related device manuals are listed below.

1. ION C4120 Install Guide, 33549
2. ION S4120 Install Guide , 33550 (this manual)
3. ION x4120 Web User Guide, 33551
4. ION x4120 CLI Reference, 33552
5. Local Management of Cards in a Remote Un-managed Chassis
6. ION Management Module (IONMM) User Guide, 33457 and Install Guide, 33420
7. Release Notes (firmware version specific)

Note: Information in this document is subject to change without notice. All information was deemed accurate and complete at the time of publication. This manual documents the latest software/firmware version. While all screen examples may not display the latest version number, all of the descriptions and procedures reflect the latest software/firmware version, noted in the [Record of Revisions](#) on page [Error! Bookmark not defined.](#) Note: Some Documentation may have Transition Networks named or pictured. Transition Networks was acquired by Lantronix in August 2021.

Models

The available models are described below in terms of ports supported.

Model #	Port 1 - Copper 10GBase-T	Port 2 - Duplex Fiber-Optic	Form Factor
C4120-1048	RJ-45 100 m (328 ft)	10GE SFP+	ION Chassis Card
S4120-1048	RJ-45 100 m (328 ft)	10GE SFP+	Stand-alone device

Lantronix' SFP+ modules fully comply with Multi-Sourcing Agreement (MSA). For more technical data go to our [SFP webpage](#).

Features

- Transparent Link Pass Through
- Auto-Negotiation & Auto-MDI/MDIX
- Automatic Link Restoration
- Loopback on Fiber and Copper
- DMI (Diagnostic Monitoring Interface)
- Supports Remote In-band Management and Remote Firmware Upgrade when linked to a C4120 card installed in a managed ION chassis
- Supports 100m on Cat6a or higher cable
- Management via CLI and Web UI

Ethernet PHY Interfaces

The Ethernet PHY interfaces supported include 10GBase-LRM, 10GBase-SR, 10GBase-LR, 10GBase-ER, 10GBase-ZR, and 10GBase-T.

Standards

S4120 standards and cabling support is described below.

10-Gigabit Ethernet Standards

802.3ae (see <http://www.ieee802.org/3/ae/index.html>).

802.3an (see <http://www.ieee802.org/3/an/index.html>).

(Not supported: 802.3ak, 802.3-2005, 802.3ap, 802.3aq, 802.3-2008.)

The fiber cable physical characteristics must meet or exceed IEEE 802.3ae specifications:

Single mode fiber (recommended):	9 μ m
Multimode fiber (recommended):	62.5/125 μ m
Multimode fiber (optional):	100/140, 85/140, 50/125 μ m

10-Gigabit Ethernet Fiber Port

The S4120 supports:

10GBase-SR: The most common type of fiber-optic 10GbE cable that supports an SFP+ connector with an optical transceiver rated for 10Gb transmission speed (also known as “short reach” fiber-optic cables).

10GBase-LR: The the “long reach” fiber optic cables that support single-mode fiber optic cables and connectors. Provides serialized data at a line rate of 10.3125 Gbit/s. 10GBASE-LR has a specified reach of 10 kilometres (6.2 mi), but 10GBASE-LR optical modules can often manage distances of up to 25 kilometres (16 mi) with no data loss.

10GBase-ER: The "extended reach" port type for single-mode fiber that uses 1550 nm lasers. Its Physical Coding Sublayer 64b/66b PCS is defined in IEEE 802.3 Clause 49 and its Physical Medium Dependent PMD in Clause 52. It delivers serialized data at a line rate of 10.3125 Gbit/s.

10GBase-ZR: An 80 km (50 mile) range ER pluggable interface, the 80 km PHY is not specified within the IEEE 802.3ae standard, and manufacturers have created their own specifications based on the 80 km PHY described in the OC-192/STM-64 SDH/SONET specifications.

10GBase-LRM: The “Long Reach Multimode” originally specified in IEEE 802.3aq; a port type for multimode fiber that uses 1310 nm lasers. Its Physical Coding Sublayer 64b/66b PCS is defined in IEEE 802.3 Clause 49 and its Physical Medium Dependent PMD is defined in Clause 68. It delivers serialized data at a line rate of 10.3125 Gbit/s. 10GBASE-LRM supports distances up to 220 metres (720 ft) on FDDI-grade multimode fiber and the same 220m maximum reach on OM1, OM2 and OM3 fiber types.

The S4120 does not support 10GBase-LX4 or 10GBase-CX4.

10-Gigabit Ethernet Optical Fiber

The S4120 supports:

SMF (Single-mode Fiber) usually yellow.

MMF (MultiMode Fiber) usually orange or aqua.

10-Gigabit Ethernet Copper Port

10GBASE-T: standard released in 2006 to provide 10 Gbps connections over unshielded or shielded twisted pair cables, at distances up to 100 meters (330 ft.).

SFP+ Direct Attach: Also known as SFP+, DA (Direct Attach), 10GSFP+Cu, 10GBASE-CR, 10GBASE-CX1, or 10GbE Cu SFP cable. SFP+ Direct Attach uses a passive twin-ax cable assembly and connects directly into an SFP+ housing. SFP+ Direct Attach has a fixed-length cable, typically 1 to 7 meters for passive cables, or up to 15 meters for active cables.

Category 6a Cable

Cat6a - Augmented Category 6 Cable: Category 6a is required to reach the full distance of 100 meters (330 ft.).

Application Examples

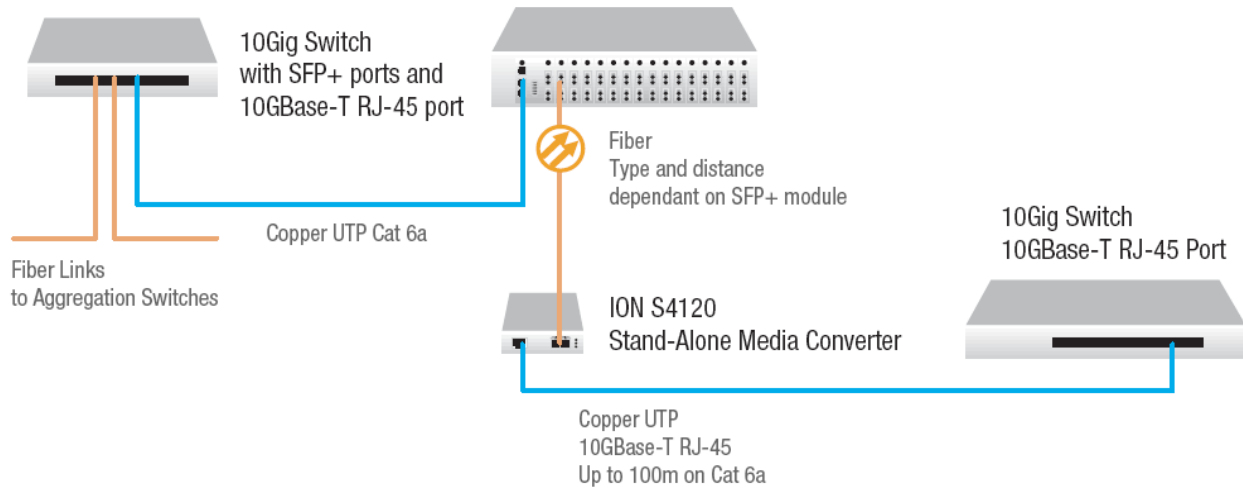

Figure 1: 10Gig Switch to Switch

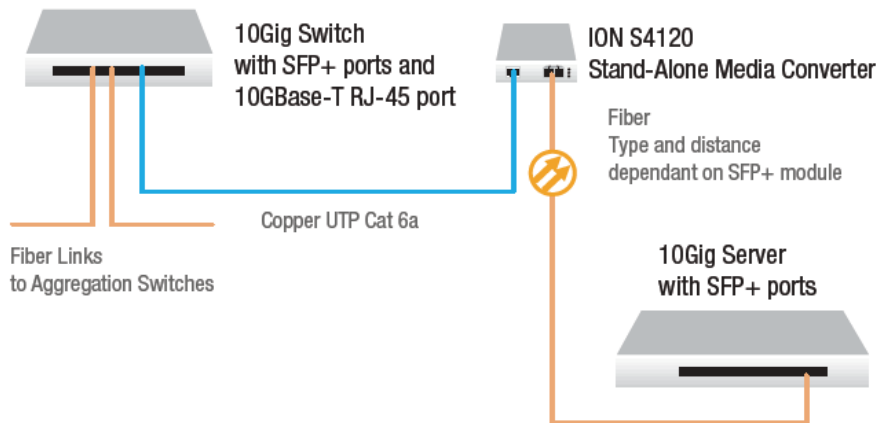

Figure 2: 10Gig Switch to Server

Product Features

The S4120 supports these features:

- Transparent Link Pass Through
- Auto-Negotiation
- Auto-MDI/MDIX
- Automatic Link Restoration
- Loopback on Fiber and Copper
- DMI
- Support Remote In-band Management and Remote Firmware Upgrade when linked to a C4120 card installed in a managed ION chassis
- Fiber Port supported standards:
 - 10GBase-SR
 - 10GBase-LRM
 - 10GBase-LR
 - 10GBase-ER
 - 10GBase-ZR
- The open SFP+ port also supports Direct attached 10G copper cable assemblies (both Class-I and Class-II fiber – SFP+ modules and SFP modules supporting WDM technology)
- Support 100m on Cat 6a or higher cable per Energy Efficient Ethernet standards, IEEE 802.3az, cable length is detected and power is adjusted according, to reduce power consumption on shorter cable installs

The features are described below.

10GbE Support

The S4120 supports the 10GBase-SR, 10GBase-LRM, 10GBase-LR, 10GBase-ER, 10GBase-ZR, and 10Gbase-T specifications.

10GbE Standards

The S4120 supports the IEEE 802.3an and IEEE 802.3ae standards.

Remote In-band Management

The S4120 supports remote in-band management. The ION S4120 can be managed through SNMP. A C4120 (chassis version) must be used in conjunction with S4120. The Remote in-band management over fiber allows administrators access to the remote device to check status and enable/disable features or the device itself.

Remote management is a proprietary protocol, through that IONMM, that can manage an S4120 which is connected by C4120 to IONMM. The RM protocol eliminates the difference between C4120 and S4120 for IONMM managements and its upper layer applications.

DMI (Diagnostic Monitoring Interface)

The S4120 supports DMI Optical Management. NID models with Diagnostic Monitoring Interface (DMI) support allow diagnosing problems within the network. DMI devices have four functions:

- Transmit power
- Receive power
- Transmit bias current
- Temperature

Within each function, the DMI device will send a trap whenever a high or low warning event or high or low alarm event occurs (16 traps total). If both the local and remote NIDs are DMI models, the DMI device will indicate whether the trap event is from a local or remote device. Optical SFP transceivers support digital diagnostics monitoring (DDM) functions per industry-standard SFF-8472. The SFP+ (enhanced small form-factor pluggable) is an enhanced version of the SFP that supports data rates up to 10 Gbps.

Transparent Link Pass-Through (TLPT)

TLPT will notify an end device of a link failure just like LPT, but it uses a different method for “passing through” this information. TLPT sends a link loss signal over the fiber, instructing the remote converter to shut down the copper port thus notifying the end device, while maintaining the fiber link between the two converters.

TLPT functions as follows:

- The End device is automatically notified with link loss, and
- The Fiber link remains up as it carries a link loss signal.

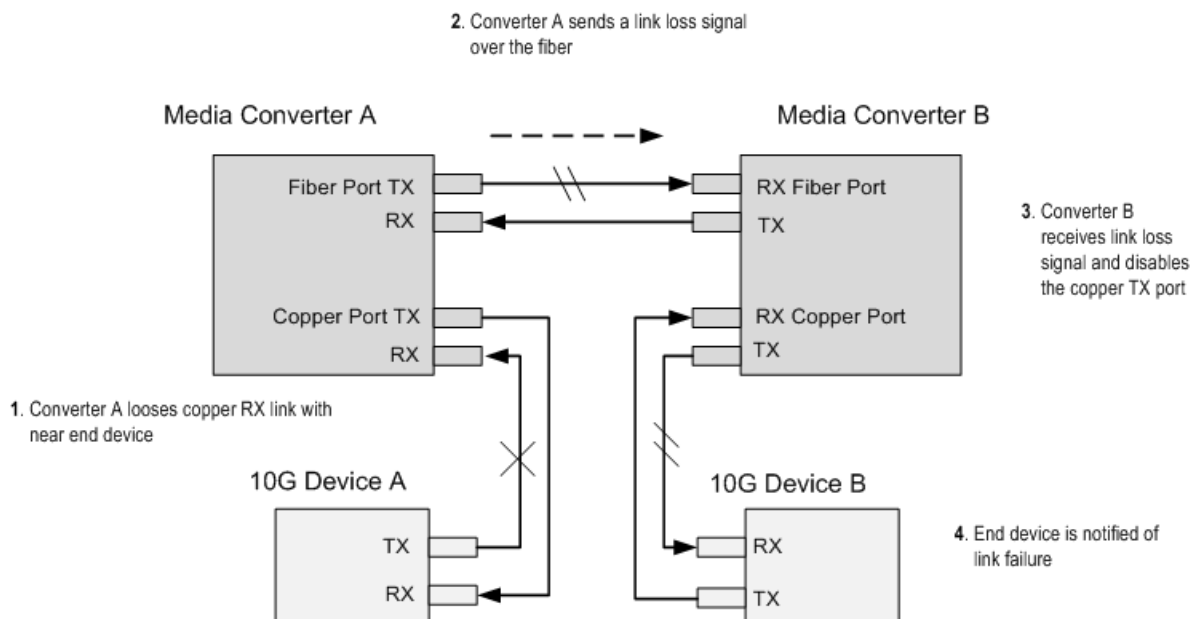

The TLPT function is configurable via the Web UI and the CLI in software mode. In hardware mode or standalone mode, it is configured via the DIP switch. The configuration option is enable/disable.

Auto Link Restore

The S4120 will automatically restore the link between networked devices after a fault condition has been corrected. The ION S4120 supports Automatic Link Restoration on both ports.

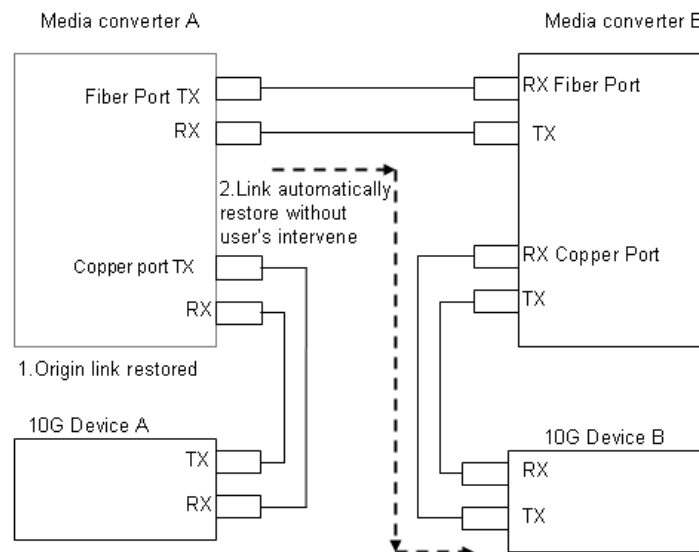

Loopback (Interface Loopback Modes)

The loopback enables the received packet from RX to TX. This feature can be useful for test and debug purposes. The Loopback function is configured via the Web UI and the CLI in software mode. In hardware mode and standalone mode, loopback can be enabled or disabled via the DIP switch.

The ION x4120 provides PHY level loopback functions. You can set loopback individually for either port through the software interface and on the stand-alone in hardware mode. You can also set loopback individually for either port via the DIP switch.

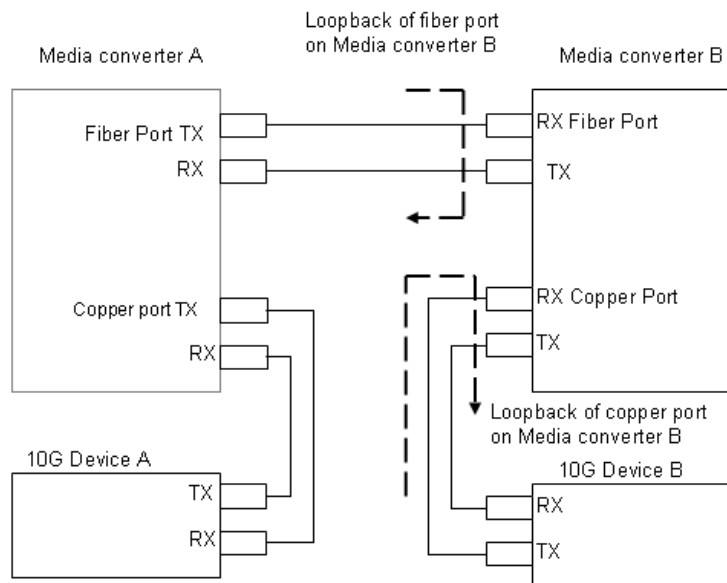

AutoCross

The AutoCross feature allows either straight-through (MDI) or crossover (MDI-X) cables to be used when connecting to devices such as hubs, transceivers, or network interface cards (NICs). AutoCross determines the characteristics of the cable connection and automatically configures the unit to link up, regardless of the cable configuration.

Auto-Negotiation

The Auto-Negotiation feature allows the S4120 to configure itself to achieve the best possible mode of operation over a link, automatically. Auto-Negotiation allows quick and easy installation because the optimal link is established automatically. No user intervention is required to determine the best mode of operation.

Remote Management in an Unmanaged Chassis

ION x4120 Version 1.2.6 was released August 12, 2016. This release added:

- Support for the management of a C4120 when installed in an unmanaged ION chassis. Management is supported by another C4120 installed in a managed chassis when the two are linked together via a fiber cable. On initial power up, additional time, approximately 1min & 10sec, is now required for the cards to be displayed in the management interface. This time is needed for the cards to determine if they are installed in a managed or an unmanaged chassis.
- Support for remote firmware upgrades of a C4120 in an unmanaged chassis. Remote firmware upgrades in an unmanaged chassis is supported only after a factory bootloader upgrade is performed. Remote firmware upgrades in an unmanaged chassis can take up to 3 minutes to transfer the file, reboot, search for management module, and display card in management interface.

For more information see *“Local Management of Cards in a Remote Un-managed Chassis”*.

For More Information

Lantronix has designed their full-featured products to include the most advanced features on the market today. Please use the following resources to learn more about [these](#) advanced features.

- For Lantronix Drivers, Firmware, etc. go to the [S4120 Product](#) page.
- For Lantronix Manuals, Brochures, Data Sheets, etc. go to the [Support Library](#) (no logon required).
- For SFP manuals see Lantronix [SFP webpage](#).
- [ANSI](#) T1.403-1999 - Network and Customer Installation Interface info@ansi.org
- ITU-T [Recommendations](#) page.
- IEEE 802 [Standards](#) page or [802.3](#) page
- Metro Ethernet Forum – MEF [Specifications](#) page.
- IETF [Request for Comments](#) (RFC) page.
- The [TIA](#) (Telecommunications Industry Association) [Standards](#) page.

Installation

CAUTION: Wear a grounding device and observe electrostatic discharge precautions when handling the media converter. Failure to observe this caution could result in damage or failure of the media converter.

4-Position DIP Switch

The S4120 has a 4-position DIP switches mounted on the PC board. The DIP switch is located on the side of the S4120.

Use a small, flat-blade screwdriver (or a similar tool) to set the switches according to site requirements (see below).

SW 1 and 2 (Loopback):	SW1	SW2	
No Loopback	Up	Up	
Copper Loopback	Down	Up	
Fiber Loopback	Up	Down	
No Loopback	Down	Down	
SW 3:	Reserved (not used)		
SW 4 (TLPT):	Up = TLPT Enabled	Down = TLPT Disabled	

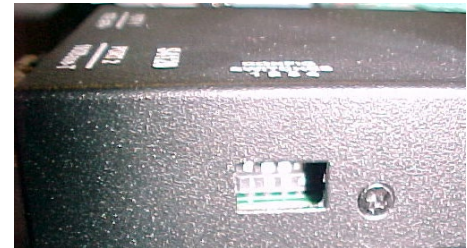

The factory default setting is SW1 – SW4 in the Up position (all Up).

Hardware/Software Mode Jumper (J8)

The hardware/software 3-pin header (J8) is located on the circuit board, labeled **H** and **S** in the figure below.

Note: Use a small needle-nose pliers to set the jumper.

H –Hardware: With Pins 1 & 2 jumpered (shorted) the S4120 mode is determined by the 4-position switch (hardware) settings.

S –Software: With Pins 2 & 3 jumpered (shorted) the S4120 mode is determined by the most-recently saved, onboard microprocessor (software config file) settings.

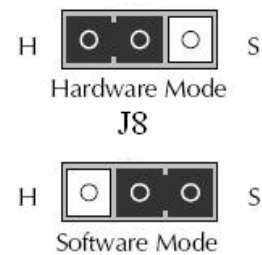

Use the CLI command “**show card info**” to show the current Config mode setting (*hardware* or *software*).

From the web GUI, navigate to the ION Stack > Chassis > C4120 menu path and check the MAIN tab’s System Configuration section > Configuration Mode field setting (*hardware* or *software*).

See the related manual for more information.

S4120 Port Locations

S4120 has two ports; Port 2 on the left labeled 10GE SFP+ and Port 1 on the right labeled 10GBase-T:

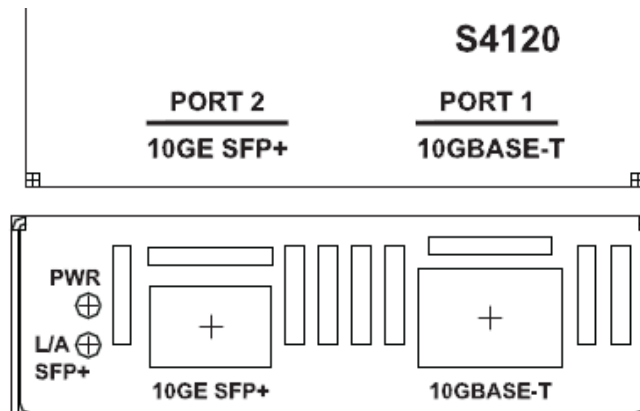

Installing SFP+ Devices

The S4120 lets you install a SFP+ device of your choice in order to make a fiber connection. The S4120 has a single SFP+ port.

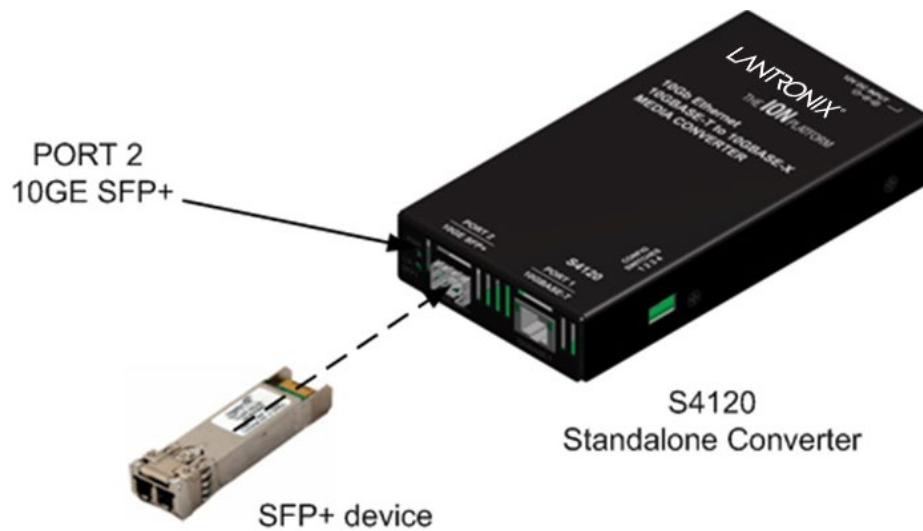

Figure 3: SFP+ Installation

SFP/XFP Optical Transceivers

Lantronix SFPs and XFPs are small form factor, hot-pluggable transceivers which allow for a single piece of network equipment to be connected to a multitude of interfaces, protocols, and transmission media via the SFP/XFP port.

All Lantronix SFPs and XFPs are compliant with the Multi-Sourcing Agreement (MSA) ensuring interoperability with all other MSA compliant networking devices.

To install an SFP+ in the S4120:

1. Position the SFP+ device at either installation slot, with the label facing up.
2. Carefully slide the SFP+ device into the slot, aligning it with the internal installation guides.
3. Ensure that the SFP+ device is firmly seated against the internal mating connector.
4. Connect the fiber cable to the fiber port connector of the SFP+ device.

See the Lantronix [SFP/XFP Optical Transceivers](#) web page for the latest information.

Cabling

The S4120 can be used to convert a 10GE fiber port to 10GE copper port, or vice versa. The S4120 can be used in telecom and enterprise applications where 10 GB Ethernet switches are already in place. Most 10 GB switches have a combination of copper and fiber ports, typically with more fiber ports than copper ports. When all the fiber ports are consumed, the S4120 can be used to convert one copper port to fiber. The S4120 can also convert 10 GB fiber ports to copper.

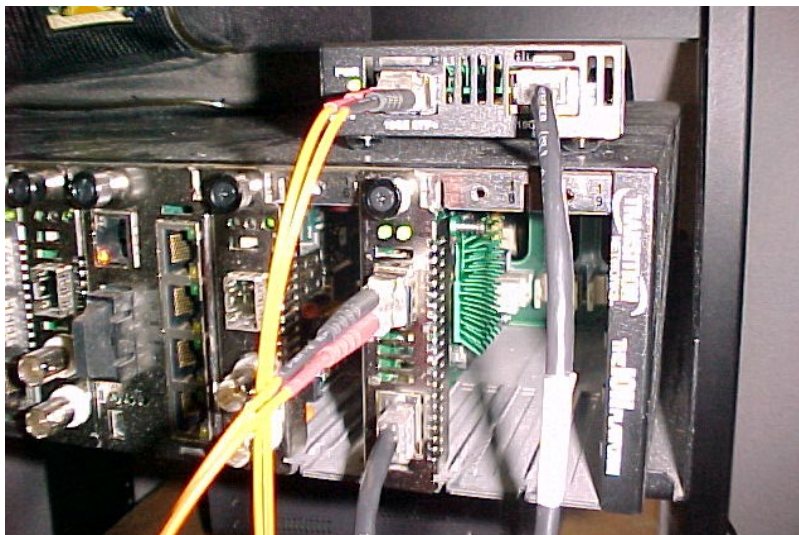

The figure above shows cabling a C4120 to an S4120. The procedures for fiber cable and copper cable installation are provided below.

Install Fiber and Copper Cable

Port 2: 10GE SFP+ Fiber Port

1. Locate a fiber cable with male, two-stranded TX to RX connectors installed at both ends. See “[Cable Specifications](#)” on page 16 for details.
2. Connect the fiber cable to the 10GE SFP+ fiber port (*Port 1* labeled **10GE SFP+**) on the S4120 as described:
 - Connect the male TX cable connector to the female TX connector.
 - Connect the male RX cable connector to the female RX connector.
3. Connect the fiber cables to the 10GE fiber port on the other device (*another media converter, hub, C4120, etc.*) as described:
 - Connect the male TX cable connector to the female RX connector.
 - Connect the male RX cable connector to the female TX connector.

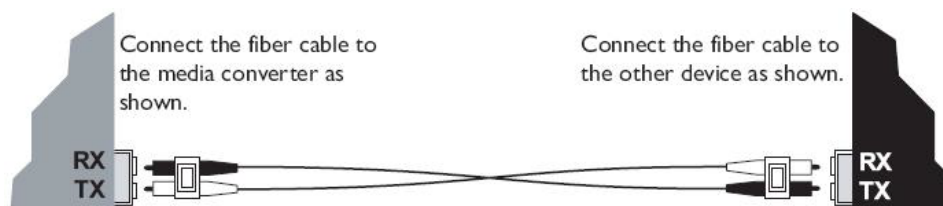

Port 1: 10GBase-T Copper Port

1. Locate a cable with the applicable connectors installed at both ends. See “[Cable Specifications](#)” on page 16 for details.
2. Connect the connector at one end of the cable to the S4120 Port 2 (labeled **10Gbase-T**).
3. Connect the connector at the other end of the cable to the copper port on the other device (*switch, workstation, etc.*).



Power Supply Included

For the corresponding country-specific power supply, add the extension to the end of the SKU. For example: -NA = North America, -LA = Latin America. -EU = Europe, -UK = United Kingdom, -SA = South Africa, -JP = Japan, -OZ = Australia, -BR = Brazil.

IONMM Installation

For IONMM Management Module installation information, see the *IONMM Install Guide*, 33420. For IONMM operation, see the *ION Management Module (IONMM) User Guide*, 33457 (if applicable).

Operation

Status LEDs

Use the status LEDs to monitor S4120 operation in the network.



Power and Fiber Status LEDs

The status LEDs (labeled **PWR** and **L/A SFP+**) are located next to the fiber port (Port 2).

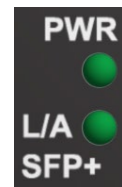

LED Label	Meaning	Operation
PWR	Power	ON = Connection to chassis power.
L/A SFP+	Link Activity on the 10GE SFP+ (fiber) port	ON = A link has been established for the fiber connection (link OK). Off = Link fail. Flashing = The fiber connection is transmitting (Link OK and Activity OK).

Copper Status LEDs

The Status LEDs for the copper port (Port 1 / 10GBase-T) are shown and described below.

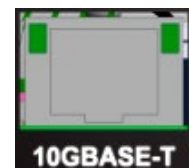

LED / Location	Meaning	Operation
Copper Link / top left	Copper port link status	On = Copper link OK. Off = Copper link failure.
Copper Act / top right	Copper port activity status	Off = No copper activity Flash = Copper activity

Cable Specifications

The physical characteristics must meet or exceed IEEE 802.3™ specifications.

10G SFP+: SFP+, both Class-I and Class-II, 10.3125Gbps.

10Gbase-T: RJ-45, 10Gbps.

Copper Cable

Category 6a (minimum requirement)

- Straight-through or crossover twisted-pair cable may be used.
- Shielded (STP) or unshielded (UTP) twisted-pair cable may be used.
- All pin pairs (1&2, 3&6, 4&5, 7&8) are active pins in a 10G Ethernet network.
- Use only dedicated wire pairs for the active pins (*e.g., blue/white & white/blue, orange/white & white/orange, etc.*)
- Do not use flat or silver satin wire.

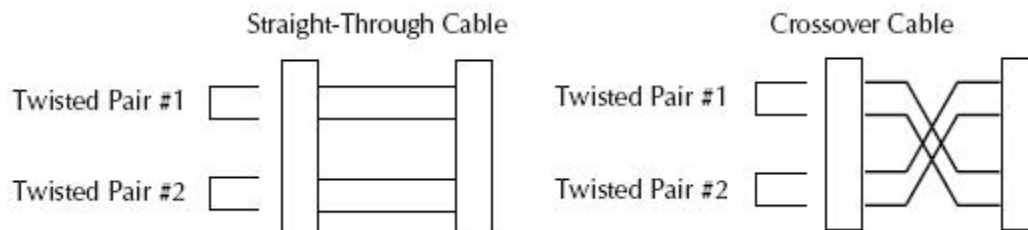

Cable Types

The cabling specifications are provided for troubleshooting purposes.

Copper (TP / UTP) CAT 1 – CAT 7 Cabling

ANSI/EIA Standard 568 is one of several standards that specify "categories" (each a "CAT") of twisted pair cabling systems. Assigned by the American National Standards Institute/Electronic Industries Association, these standards categories include CAT 1 – CAT 7, as shown below.

Table 7: Copper Cable Descriptions

Category	Max Data Rate	Typical Application
CAT 5	100 MHz	100 Mbps TPDDI. 155 Mbps ATM. No longer supported; replaced by 5E. 10/100BASE-T.
CAT 5E	100 MHz	100 Mbps TPDDI, 155 Mbps ATM, Gigabit Ethernet. Offers better near-end crosstalk than CAT 5.
CAT 6	Up to 250 MHz	Minimum cabling required for data centers in TIA-942. CAT 6 is quickly replacing CAT 5e.
CAT 6a	Up to 500 MHz	Field-tested to 500 MHz. Supports 10 Gigabit Ethernet (10GBASE-T). May be either shielded (STP, ScTP, S/FTP) or unshielded (UTP). Standard published in Feb. 2008. The minimum requirement for Data Centers in the ISO Data Center standard.
CAT 7 (ISO Class F)	600 MHz, 1.2 GHz in pairs with Siemon connector	Full-motion video, Teleradiology, Government and manufacturing environments. Fully Shielded (S/FTP) system using non-RJ45 connectors but backwards compatible with hybrid cords. Standard published in 2002. Until Feb. 2008, the only standard to support 10GBASE-T for a full 100m.

CAT 7A/Class FA and Category 6a/Class EA specifications were published in February 2008.

Common forms of 10GbE copper cables include:

10GBASE-CR: currently the most common type of copper 10GbE cable is the 10GBase-CR cable that uses an attached SFP+ connector, also known as a Direct Attach Copper (DAC). This fits into the same form factor connector and housing as the fiber-optic cables with SFP+ connectors. Many 10GbE switches accept cables with SFP+ connectors, which support both copper and fiber-optic cables. These cables are available in 1m, 3m, 5m, 7m, 8.5m and longer distances. The most commonly deployed distances are 3m and 5m.

Passive and Active DAC: Passive copper connections are common with many interfaces. The industry is finding that as the transfer rates increase, passive copper does not provide the distance needed and takes up too much physical space. The industry is moving towards an active copper type of interface for higher speed connections. Active copper connections include components that boost the signal, reduce the noise and work with smaller gauge cables, improving signal distance, cable flexibility and airflow.

10GBASE-T: These cables and connectors are similar to, but not the same as the cables used for 1000BASE-T. 10GBASE-T cables are Cat6a (Category 6 augmented), also known as Class EA cables. These support the higher frequencies required for 10Gb transmission up to 100 meters (330 feet). Cables must be certified to at least 500MHz to ensure 10GBASE-T compliance. Cat7 (Category 7, Class F) cable is also certified for 10GBASE-T compliance and is typically deployed in Europe. Cat6 cables may work in 10GBASE-T deployments up to 55m but should be tested first. Some newer 10GbE switches support 10GBASE-T (RJ45) connectors.

Cat 6 (Category 6) Copper Cable

Category 6 cable, commonly referred to as Cat 6, is a standardized cable for Gigabit Ethernet and other network physical layers that is backward compatible with the Category 5/5e and Category 3 cable standards. Compared to Cat 5 and Cat 5e, Cat 6 provides more stringent specifications for crosstalk and system noise. The Cat 6 cable standard provides performance of up to 250 MHz and is suitable for 10BASE-T, 100BASE-TX (Fast Ethernet), 1000BASE-T/1000BASE-TX (Gigabit Ethernet) and 10GBASE-T (10-Gigabit Ethernet). Category 6 cable has a reduced maximum length when used for 10GBASE-T.

Like most of the earlier twisted-pair cables, Category 6 cable contains four twisted wire pairs. Attenuation, near end crosstalk (NEXT), and PSNEXT (power sum NEXT) in Cat 6 cable and connectors are all much lower than Cat 5 or Cat 5e, which uses 24 AWG wire. The increase in performance with Cat 6 comes mainly from increased (22 AWG) wire size. Because the conductor sizes are generally the same, Cat 6 jacks may also be used with Cat 5e cable.

Category 6 cable can be identified by the printing on the side of the cable sheath. Cat 6 patch cables are normally terminated in 8P8C modular connectors. If Cat 6 rated patch cables, jacks, and connectors are not used with Cat 6 wiring, overall performance is degraded to that of the cable or connector.

Connectors use either T568A or T568B pin assignments; although performance is comparable provided both ends of a cable are the same, T568B is a deprecated standard in the US and no longer supported by TIA.

Category 6a Copper Cable (Augmented Category 6)

Category 6a cable, or Augmented Category 6, is characterized to 500 MHz and has improved alien crosstalk characteristics, allowing 10GBASE-T to be run for the same distance as previous protocols.

The latest standard from the TIA for enhanced performance standards for twisted pair cable systems was defined in February 2008 in ANSI/TIA/EIA-568-B.2-10. Category 6a is defined at frequencies up to 500 MHz—twice that of Cat. 6. Category 6a performs at improved specifications, in particular in the area

of alien crosstalk, as compared to Cat 6 UTP (unshielded twisted pair), which exhibited high alien noise in high frequencies.

The global cabling standard ISO/IEC 11801 has been extended by the addition of amendment 2, which defines new specifications for Cat 6a components and Class EA permanent links. These new global Cat 6a/Class EA specifications require a new generation of connecting hardware, which offer superior performance compared to existing products based on the American TIA standard.

Note the performance difference between ISO/IEC and EIA/TIA component specifications for the NEXT transmission parameter. At a frequency of 500 MHz, an ISO/IEC Cat 6a connector performs 3 dB better than a Cat 6a connector that conforms to the EIA/TIA specification. The 3 dB represents a 100% increase of near-end crosstalk noise reduction when measured in absolute magnitudes.

Maximum Length

When used for 10GBase-T, the maximum allowed length of a Cat 6 cable is 100 meters or 328 feet. This consists of 90 meters (300 ft) of solid "horizontal" cabling between the patch panel and the wall jack, plus 10 meters (33 ft) of stranded patch cable between each jack and the attached device. Since stranded cable has higher attenuation than solid cable, exceeding 10 meters of patch cabling will reduce the permissible length of horizontal cable.

When used for 10GBASE-T, Cat 6 cable's maximum length is 55 meters (180 ft) in a favorable alien crosstalk environment, but only 37 meters (121 ft) in a hostile alien crosstalk environment, such as when many cables are bundled together. However, because the effects of alien crosstalk environments on cables are difficult to determine prior to installation, it is highly recommended that all Cat 6 cables being used for 10GBASE-T are electrically tested once installed. With its improved specifications, Cat6 A does not have this limitation and can run 10GBASE-T at 100 meters (330 ft) without electronic testing.

Installation Notes

Category 6 and 6a cable must be properly installed and terminated to meet specifications. The cable must not be kinked or bent too tightly (the bend radius should be at least four times the outer diameter of the cable). The wire pairs must not be untwisted and the outer jacket must not be stripped back more than 1/2 inch (1.27 cm).

All shielded cables must be grounded for safety and effectiveness and a continuous shield connection maintained from end to end. Ground loops develop when there is more than one ground connection and the difference in common mode voltage potential at these ground connections introduces noise into the cabling.

Note that 23 or 24 AWG wire is allowed if the ANSI/TIA-568-B.2-1 performance specifications are met.

The figure below shows the pins on the plug face; note that the socket is the reverse of the plug pinout shown below.

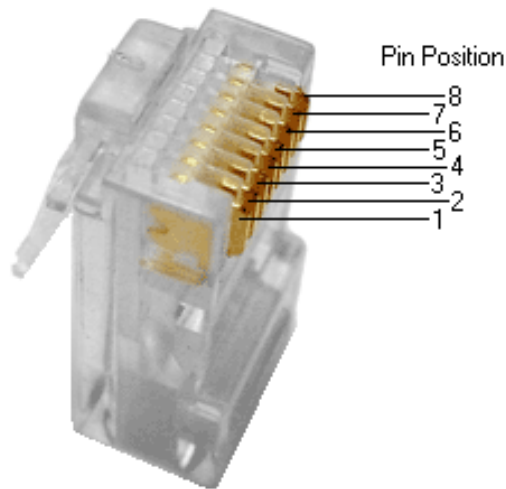

Figure 20: Category 6 Plug Face Pins

For more information, see the TIA web site or the IEEE web site.

Troubleshooting Cat 6 & Cat 6a Structured Copper Cabling Systems

If a Category 6 cabling system does not meet the electrical requirements for supporting 10GBASE-T applications, see the TSB-155 provides guidelines designed to mitigate the alien crosstalk between the target pair and the disturbing pairs of Category 6 channels and permanent links. Annex B of TSB-155 outlines the following mitigation actions most appropriate for individual situations:

- Use Category 6 shielded or Category 6a patch cords;
- Replace Category 6 connectors with Category 6a connectors;
- Use non-adjacent patch panel positions;
- Separate equipment cords and patch cords;
- Unbundle or more loosely bundle the horizontal cabling; and
- Reconfigure the cross-connect as an interconnect.

Fiber (10GbE) Cabling

The two general types of fiber optic cables are SMF (single-mode fiber) and MMF (multi-mode fiber).

SMF has an optical core of approximately 9 μm (microns), and has lower modal dispersion than MMF, and can support distances of at least 10 Km and as high as 80-100 Km (Kilometers) or more, depending on transmission speed, transceivers, etc..

MMF has an optical core of either 50 μm or 62.5 μm , and it supports distances up to 600 meters, depending on transmission speeds and transceivers.

Table 8: Fiber Cable Descriptions

Standard	Cable Type	Core Diameter	IEEE Standard Distance	Wavelength
OM1	Multi-mode (MMF)	62.5/125 μm	33 meters (SR)	850 / 1300 nm
OM2	Multi-mode (MMF)	50/125 μm	82 meters (SR)	850 / 1300 nm
OM3	Multi-mode (MMF)	50/125 μm	300 meters (SR)	850 / 1300 nm
OM4	Multi-mode (MMF)	50/125 μm	550 meters (SR)	850 / 1300 nm
OS1	Single mode (SMF)	9 μm	up to 10,000m	1310 / 1550 nm

OS1 SMF optics are used for distances up to 10,000m (6.2 miles) with standard transceivers and can work at longer distances with special transceivers and switching infrastructure.

The S4120 supports:

10GBase-SR: The most common type of fiber-optic 10GbE cable that supports an SFP+ connector with an optical transceiver rated for 10Gb transmission speed (also known as “short reach” fiber-optic cables).

10GBase-LR: The the “long reach” fiber optic cables that support single-mode fiber optic cables and connectors. Provides serialized data at a line rate of 10.3125 Gbit/s. 10GBASE-LR has a specified reach of 10 kilometres (6.2 mi), but 10GBASE-LR optical modules can often manage distances of up to 25 kilometres (16 mi) with no data loss.

10GBase-ER: The "extended reach" port type for single-mode fiber that uses 1550 nm lasers. Its Physical Coding Sublayer 64b/66b PCS is defined in IEEE 802.3 Clause 49 and its Physical Medium Dependent PMD in Clause 52. It delivers serialized data at a line rate of 10.3125 Gbit/s.

10GBase-ZR: An 80 km (50 mile) range ER pluggable interface, the 80 km PHY is not specified within the IEEE 802.3ae standard, and manufacturers have created their own specifications based on the 80 km PHY described in the OC-192/STM-64 SDH/SONET specifications.

10GBase-LRM: The “Long Reach Multimode” originally specified in IEEE 802.3aq; a port type for multimode fiber that uses 1310 nm lasers. Its Physical Coding Sublayer 64b/66b PCS is defined in IEEE 802.3 Clause 49 and its Physical Medium Dependent PMD is defined in Clause 68. It delivers serialized data at a line rate of 10.3125 Gbit/s. 10GBASE-LRM supports distances up to 220 metres (720 ft) on FDDI-grade multimode fiber and the same 220m maximum reach on OM1, OM2 and OM3 fiber types.

The S4120 does not support 10GBase-LX4 or 10GBase-CX4.

Technical Specifications

The Lantronix S4120 meets the following specifications.

Standards:	IEEE802.3, IEEE 802.3an, IEEE 802.3ae, IEEE 802.3az
Data Rate:	10 Gbps
Status LEDs:	PWR (Power): On = power is on L/A SFP+ (Fiber port link and activity status): On = Link OK Flashing = Link and Activity OK Copper Link (Copper port link status): On = Copper link OK. Off = Copper link failure. Copper Act (Copper port activity status): Off =No copper activity Flash = Copper activity
DIP Switches:	SW1: Copper Loopback SW2: Fiber Loopback SW3: not used SW4: Transparent Link Pass Through
Dimensions:	Width: 3.25" [82.55 mm] x Depth: 6.5" [165 mm] x Height: 1.0" [25.4 mm]
Power Consumption:	10.5 watts
Power Supply:	External AC/DC power supply, Universal AC input, 12VDC 1.6A output
Environment Operating Temp:	0°C – 50°C
Storage Temp:	-15°C to +65°C
Operating Humidity:	5% to 95% (non condensing)
Altitude:	0 – 10,000 feet
Shipping Weight:	2 lbs
MTBF w/Power Supply:	Greater than 41,660 hours (MIL-HDBK-217F) Greater than 114,580 hours (Bellcore)
MTBF w/o Power Supply:	Greater than 250,000 hours (MIL-HDBK-217F) Greater than 687,000 hours (Bellcore)
Regulatory Compliance:	FCC Class A, EN55022 Class A, EN55024, CE Mark; NDAA and TAA compliant
Warranty:	Lifetime
Max. Frame Size:	16384 bytes jumbo frame support

The information in this install guide is subject to change.

WARNING: Visible and invisible laser radiation when open. DO NOT stare into the beam or view the beam directly with optical instruments. Failure to observe this warning could result in an eye injury or blindness.

WARNING: Use of controls, adjustments or the performance of procedures other than those specified herein may result in hazardous radiation exposure.

CAUTION: Copper based media ports, e.g., Twisted Pair (TP) Ethernet, USB, RS232, RS422, RS485, DS1, DS3, Video Coax, etc., are intended to be connected to intrabuilding (*inside plant*) link segments that are not subject to lightening transients or power faults. Copper based media ports (e.g., Twisted Pair (TP) Ethernet, USB, RS232, RS422, RS485, DS1, DS3, Video Coax, etc.) are NOT to be connected to inter-building (*outside plant*) link segments that are subject to lightening transients or power faults.

High Risk Activities Disclaimer: Components, units, or third-party products used in the product described herein are NOT fault-tolerant and are NOT designed, manufactured, or intended for use as on-line control equipment in the following hazardous environments requiring fail-safe controls: the operation of Nuclear Facilities, Aircraft Navigation or Aircraft Communication Systems, Air Traffic Control, Life Support, or Weapons Systems ("High Risk Activities"). Lantronix and its supplier(s) specifically disclaim any expressed or implied warranty of fitness for such High Risk Activities.

Troubleshooting

1. Is the PWR (power) LED lit?
NO
 - Is the power cord properly installed in the S4120 chassis and in the grounded AC outlet?
 - Does the grounded AC outlet provide power?
 - Contact Tech Support.YES
 - Proceed to step 2.
2. Is the L/A SFP+ LED lit?
NO
 - Check that the SFP+ device is supported and properly connected. See "[Installing SFP+ Devices](#)" on page 13.
 - Check the fiber cables for proper connection.
 - Verify that the cable specs are met. See "[Cable Specifications](#)" on page 16.
 - Contact Tech Support.YES
 - Proceed to step 3.
3. Is the CLI accessible?
NO
 - Check the Install process. See "[Installation](#)" on page 12.
 - Check the cabling. See "[Cable Specifications](#)" on page 16.
 - Contact Tech Support.YES
 - Proceed to step 4.
4. Is the web UI accessible?
NO
 - Check the Install process. See "[Installation](#)" on page 12.
 - Check the cabling. See "[Cable Specifications](#)" on page 16.
 - Contact Tech Support.

Compliance Information

Declaration of Conformity

Manufacture's Name: Lantronics, Inc.

Manufacture's Address: 48 Discovery, Suite 250, Irvine, California 92618 USA

Declares that the products:

C4120-1048, S4120-1048

Conform to the following Product Regulations:

FCC Part 15 Class A, EN 55032:2012, EN 55024:2010

Directive 2014/30/EU, Directive 2015/863/EU

Low-Voltage Directive 2014/35/EU

IEC /EN 60950-1:2006+A2:2013

2011/65/EU EN 50581:2012

With the technical construction on file at the above address, this product carries the CE Mark

With the technical construction on file at the above address, this product carries the CE Mark

I, the undersigned, hereby declare that the equipment specified above conforms to the above Directive(s) and Standard(s).

Place: Irvine, California

Date: April 27, 2022

Signature: *Eric Bass*

Full Name: Eric Bass

Position: Vice President of Engineering

FCC Regulations

This equipment has been tested and found to comply with the limits for a Class A digital device, pursuant to part 15 of the FCC rules. These limits are designed to provide reasonable protection against harmful interference when the equipment is operated in a commercial environment. This equipment generates, uses, and can radiate radio frequency energy and, if not installed and used in accordance with the instruction manual, may cause harmful interference to radio communications.

Operation of this equipment in a residential area is likely to cause harmful interference, in which case the user will be required to correct the interference at the user's own expense.

Canadian Regulations

This digital apparatus does not exceed the Class A limits for radio noise for digital apparatus set out on the radio interference regulations of the Canadian Department of Communications.

Le présent appareil numérique n'émet pas de bruits radioélectriques dépassant les limites applicables aux appareils numériques de la lass A prescrites dans le Règlement sur le brouillage radioélectrique édicté par le ministère des Communications du Canada.

European Regulations

Warning

This is a Class A product. In a domestic environment this product may cause radio interference in which case the user may be required to take adequate measures.

Achtung !

Dieses ist ein Gerät der Funkstörgrenzwertklasse A. In Wohnbereichen können bei Betrieb dieses Gerätes Rundfunkstörungen auftreten. In diesem Fall ist der Benutzer für Gegenmaßnahmen verantwortlich.

Attention !

Ceci est un produit de Classe A. Dans un environnement domestique, ce produit risque de créer des interférences radioélectriques, il appartiendra alors à l'utilisateur de prendre les mesures spécifiques appropriées.



In accordance with European Union Directive 2002/96/EC of the European Parliament and of the Council of 27 January 2003, Lantronix will accept post usage returns of this product for proper disposal. The contact information for this activity can be found in the 'Contact Us' portion of this document.



CAUTION: RJ connectors are NOT INTENDED FOR CONNECTION TO THE PUBLIC TELEPHONE NETWORK. Failure to observe this caution could result in damage to the public telephone network.

Der Anschluss dieses Gerätes an ein öffentliches Telekommunikationsnetz in den EGMitgliedstaaten verstösst gegen die jeweiligen einzelstaatlichen Gesetze zur Anwendung der Richtlinie 91/263/EWG zur Angleichung der Rechtsvorschriften der Mitgliedstaaten über Telekommunikationsendeinrichtungen einschliesslich der gegenseitigen Anerkennung ihrer.

**Lantronix Corporate Headquarters**

48 Discovery, Suite 250
Irvine, CA 92618, USA
Toll Free: 800-526-8766
Phone: 949-453-3990
Fax: 949-453-3995

Technical Support

Online: <https://www.lantronix.com/technical-support/>

Sales Offices

For a current list of our domestic and international sales offices, go to the Lantronix web site at www.lantronix.com/about/contact.