

ION C2110

ION Fast Ethernet Media Converter

100Base-TX to 100Base-FX

Install Guide

Part Number 33415
Revision D October 2023

Intellectual Property

© 2022, 2023 Lantronix, Inc. All rights reserved. No part of the contents of this publication may be transmitted or reproduced in any form or by any means without the written permission of Lantronix.

Lantronix is a registered trademark of Lantronix, Inc. in the United States and other countries.

All other trademarks and trade names are the property of their respective holders.

Patented: <https://www.lantronix.com/legal/patents/>; additional patents pending.

Warranty

For details on the Lantronix warranty policy, go to <http://www.lantronix.com/support/warranty>.

Contacts

Lantronix Corporate Headquarters

48 Discovery, Suite 250
Irvine, CA 92618, USA
Toll Free: 800-526-8766
Phone: 949-453-3990
Fax: 949-453-3995

Technical Support

Online: <https://www.lantronix.com/technical-support/>

Sales Offices

For a current list of our domestic and international sales offices, go to www.lantronix.com/about/contact.

Disclaimer

All information contained herein is provided "AS IS." Lantronix undertakes no obligation to update the information in this publication. Lantronix does not make, and specifically disclaims, all warranties of any kind (express, implied or otherwise) regarding title, non-infringement, fitness, quality, accuracy, completeness, usefulness, suitability or performance of the information provided herein. Lantronix shall have no liability whatsoever to any user for any damages, losses and causes of action (whether in contract or in tort or otherwise) in connection with the user's access or usage of any of the information or content contained herein. The information and specifications contained in this document are subject to change without notice.

Revision History

Rev	Date	Description
A	08/12/10	Initial release.
B	02/02/15	Update Specs, Jumper and DIP switch information and change formats.
C	8/31/23	Add max frame size, delete discontinued products, and update contact information. Initial Lantronix re-brand. FW v 1.2.0: add note on DIP switches. Add minor editorial and technical changes. FW v 2.0.0 add fix for determining the slot ID on the ION chassis.
D	10/24/23	Update features and distance specifications.

Contents

Product Description	4
Ordering Information	4
Features	4
Manageable Features	4
Distances.....	5
Applications	5
Installation	6
Configuration DIP Switches and Jumpers	6
Set the 4-position DIP Switch (SW1)	7
Set AutoCross (E/D 3-Pin Jumper) (J4).....	8
Set Hardware / Software (H/S 3-Pin Jumper) (J5)	8
J6: E/H 3-Pin Jumper (Do Not Alter).....	9
Install the C2110 in the ION Chassis	10
Connect the Fiber Cable	10
Connect the Twisted-Pair Copper Cable	11
Operation.....	11
Status LEDs	11
Product Features.....	12
Auto-Negotiation	12
Half-duplex Network (512-Bit Rule)	12
Full-Duplex Network.....	12
Pause Control Frame.....	12
Link Pass-Through (LPT).....	13
Far-End Fault (FEF).....	13
SNMP	14
Cable Specifications.....	15
Fiber Cable Specs.....	15
Copper Cable Specs	16
Technical Specifications.....	17
PCB Revision Examples	18
PCB 11348 Rev. 01	18
PCB 11348 Rev. A.....	18
PCB 11322 Rev. 02	19
PCB 11322 Rev. A.....	19
Troubleshooting	20
Compliance Information	21
FCC Regulations	21
Canadian Regulations.....	21
Declaration of Conformity.....	22

Product Description

The ION C2110 is a media converter module that provides an interface between 100Base-TX ports and 100Base-FX ports, allowing users to integrate fiber optic cabling into 100Base-TX copper environments. Operating at Layer 1, the physical layer, data is passed through the converter at line speed, making it ideal for applications where low latency is essential. The ION C2110 is a manageable device when installed in a managed ION chassis.

Note: Some Documentation may have Transition Networks named or pictured. Transition Networks was acquired by Lantronix in August 2021.

Ordering Information

C2110-1011: 100BASE-TX (RJ-45) [100 m/328 ft.] to 100BASE-FX 1300nm MM (ST) [2 km/1.2 mi.] Link Budget: 11.0 dB

C2110-1013: 100BASE-TX (RJ-45) [100 m/328 ft.] to 100BASE-FX 1300nm MM (SC) [2 km/1.2 mi.] Link Budget: 11.0 dB

C2110-1039: 100BASE-TX (RJ-45) [100 m/328 ft.] to 100BASE-FX 1300nm MM (LC) [2 km/1.2 mi.] Link Budget: 11.0 dB

C2110-1014: 100BASE-TX (RJ-45) [100 m/328 ft.] to 100BASE-FX 1300nm SM (SC) [20 km/12.4 mi.] Link Budget: 16.0 dB

C2110-1019: 100BASE-TX (RJ-45) [100 m/328 ft.] to 100BASE-FX 1300nm SM (LC) [20 km/12.4 mi.] Link Budget: 17.3 dB

C2110-1040: 100BASE-TX (RJ-45) [100 m/328 ft.] to 100Base-X SFP Slot (empty)

Features

- Auto-Negotiation of speed and duplex on TP port
- Auto-MDI/MDIX on TP port
- Link Pass Through (LPT)
- Far-End-Fault (FEF) detection
- Automatic Link Restoration
- Pause advertisement
- Field Upgradeable Firmware
- Can be used in any ION Platform Chassis
- Standards based, will link with any Standard 100Base-TX and any Standard 100Base-FX ports

Manageable Features

- Report converter status to chassis management software:
 - TP and Fiber Link Status
 - Hardware switch settings
 - Copper Port Speed
 - TP and Fiber Port Duplex
 - Fault condition
- Write operation includes:
 - Power on/off device
 - Auto-Negotiation enable/disable
 - Force half or full-duplex
 - Select advertising modes when Auto-Negotiation is enabled
 - LPT enable/disable

- FEF enable/disable
- Pause enable/disable
- Auto-MDI/MDIX enable/disable

Note: Manageable Features are available when used in an ION Platform chassis along with an ION Management Module.

Distances

Part Number	Port 1 - Copper 100Base-TX	Port 2 - Duplex Fiber-Optic 100Base-FX
C2110-1011	RJ-45 100 m (328 ft)	ST, 1300nm multimode, 2 km (1.2 miles) *
C2110-1013	RJ-45 100 m (328 ft)	SC, 1300nm multimode, 2 km (1.2 miles) *
C2110-1014	RJ-45 100 m (328 ft)	SC, 1300nm single mode, 20 km (12.4 miles) *
C2110-1019	RJ-45 100 m (328 ft)	LC, 1300nm single mode, 20km (12.4 miles) *
C2110-1039	RJ-45 100 m (328 ft)	LC, 1300nm multimode, 2km (1.2miles) *
C2110-1040	RJ-45 100 m (328 ft)	SFP slot (empty)

* Typical max. cable distance. Actual distance depends on network installation physical characteristics. Other transmission distances can be achieved with an open SFP converter (C2110-1040) and the appropriate SFP module to match your required fiber type and transmission distance.

Applications

Fiber Integration in 10/100 Copper Environments: The ION C2110 device provides an interface between 100Base-TX ports and 100Base-FX ports allowing users to integrate fiber optic cabling into 100Base-TX copper environments.

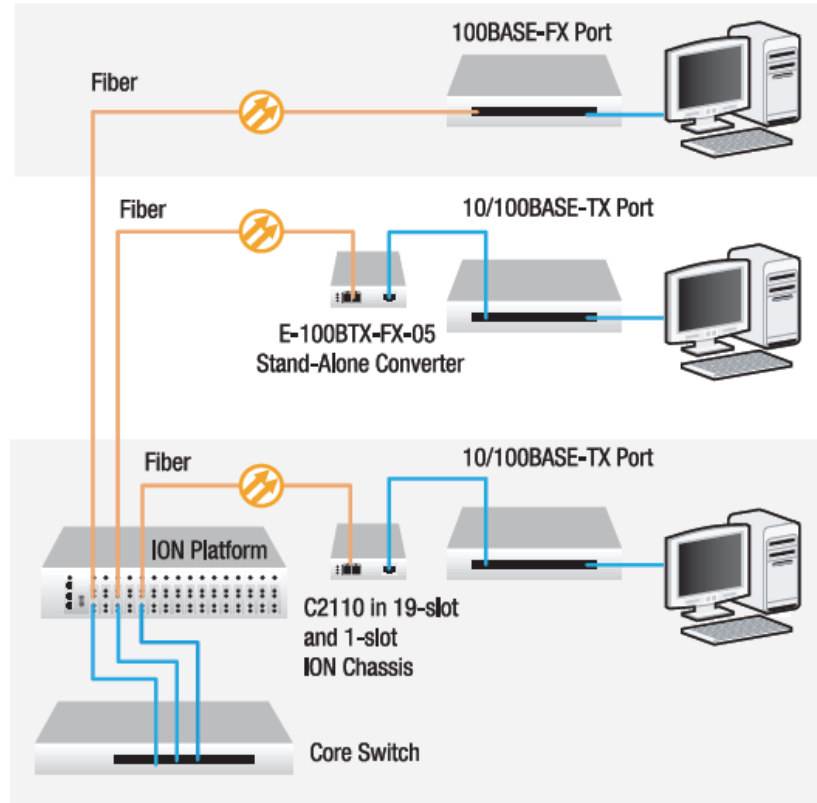

Installation

CAUTION: Wear a grounding device and observe electrostatic discharge precautions when setting the 4-position DIP switch and the jumpers. Failure to observe this caution could result in C2110 failure or damage.

Configuration DIP Switches and Jumpers

PCB # 11322 Rev. x (this information is silkscreened in the center right side of the PCB as shown below).

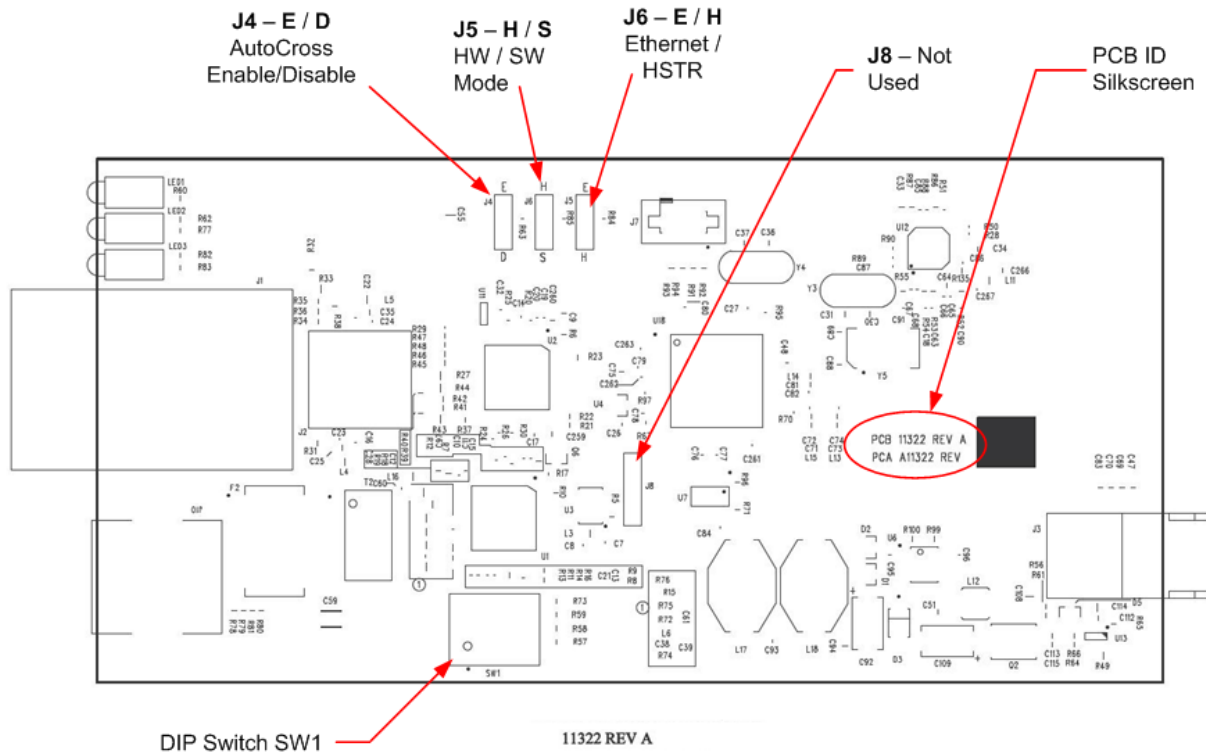

Note that PCB layout and components can vary by revision.

Set the 4-position DIP Switch (SW1)

The 4-position DIP switch is located on the edge of the printed circuit board (PCB). Use a small flatblade screwdriver to set the recessed switches. The default setting is all Up (Enabled).

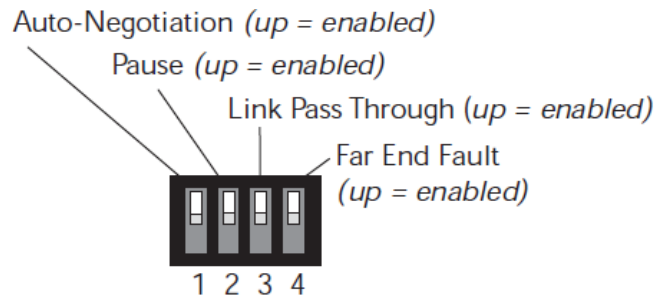
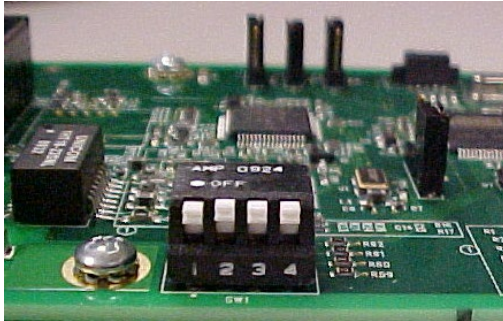

SW1 Sw #	Function	Settings
1	Auto-Negotiation	Up = Enabled: Advertises 100 Mb/s Full-Duplex and Half-Duplex (only during Auto-Negotiation). Down = Disabled: Disables Auto-Negotiation. Operates at 100 Mb/s in the mode (either full- or half-duplex) of the attached device.
2	Pause	Applies ONLY if switch “1” is Up (and the C2110 is connected to auto negotiating device(s) capable of pause control frame). Up = Enabled: Allows negotiation of pause control frame. Down = Disabled: Does not allow negotiation of pause control frame.
3	Link Pass Through (LPT)	Up = Enabled: Enables Link Pass-Through. Down = Disabled: Disables Link Pass-Through.
4	Far End Fault (FEF)	Up = Enabled: Enables Far-End Fault. Down = Disabled: Disables Far-End Fault.

Note that PCB layout and components can vary by revision.

Note: Fixes at FW v 1.2.0: while in hardware mode, only the DIP switches can be used to set product configuration. The software management interface will only display current operating and configuration status. Changes to the products configuration can no longer be set via software, while in hardware-mode. See the online [Release Notes](#) for more information.

Set AutoCross (E/D 3-Pin Jumper) (J4)

When the AutoCross feature is enabled, it allows either straight-through or crossover cables to be used when connecting to 100Base-TX devices. AutoCross determines the characteristics of the connection and automatically configures the unit to link up, regardless of the cable configuration. **Note:** AutoCross is enabled by default. Lantronix recommends leaving jumper J4 in the “Enabled” position.

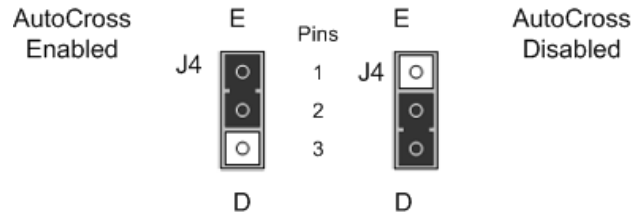
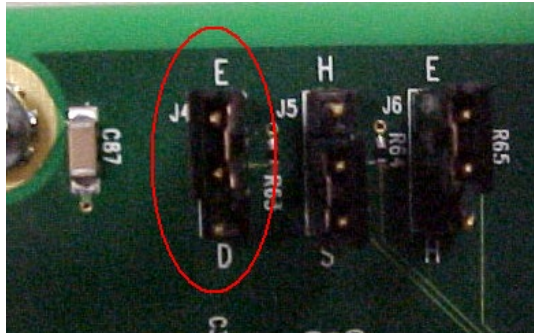

The 3-pin header **J4** for the jumper is located on the PCB and is labeled “**E**” (Enabled) and “**D**” (Disabled). The default is **E** (Enabled). Use a small needle-nose pliers to remove and position the jumper. The J4 settings are shown and described below:

E - Enable: the C2110 connects automatically to either straight-through or crossover twisted-pair copper cable.

D - Disable: either straight-through or crossover twisted pair copper cable must be installed, according to site requirements.

Set Hardware / Software (H/S 3-Pin Jumper) (J5)

The 3-pin header **J6** for the jumper is located on the PCB and is labeled “**H**” (Hardware mode) and “**S**” (Software) mode. Use a small needle-nose pliers to remove and position the jumper.

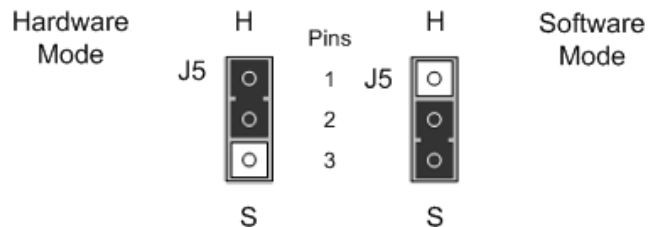
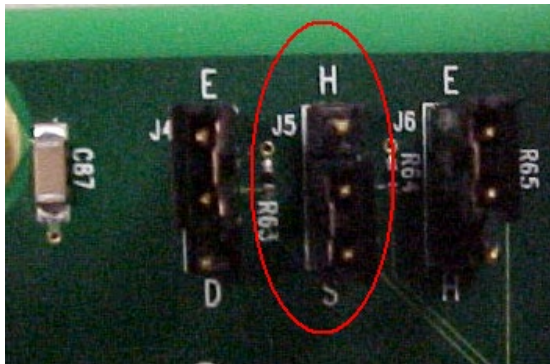

The J5 settings are shown and described below:

H - Hardware: C2110 mode is determined by the 4-position DIP switch (SW1) settings (see above). The default is **Hardware** mode.

S - Software: C2110 mode is determined by the most recently saved on-board ION software settings.

J6: E/H 3-Pin Jumper (Do Not Alter)

The default setting is "E" (Ethernet). Do not change this setting.

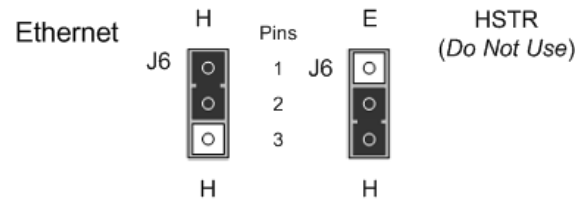
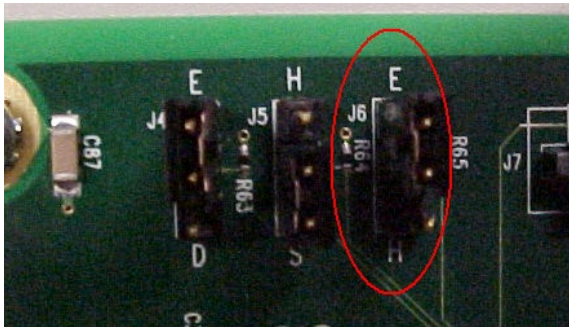

E - Ethernet: Ethernet mode of operation (Default - Leave as is).

H - HSTR: High Speed Token Ring mode. Do not use this setting.

Note that PCB layout and components can vary by revision.

Install the C2110 in the ION Chassis

CAUTION: Wear a grounding device and observe electrostatic discharge precautions when installing the C2110. Failure to observe this caution could result in damage or failure of the C2110.

1. Carefully slide the C2110 into an open ION chassis slot, aligning it with the slot guides.
2. Ensure that the C2110 is firmly seated into the slot.
3. Push in and rotate the attached panel Fastener clockwise to secure the C2110 to the ION chassis.

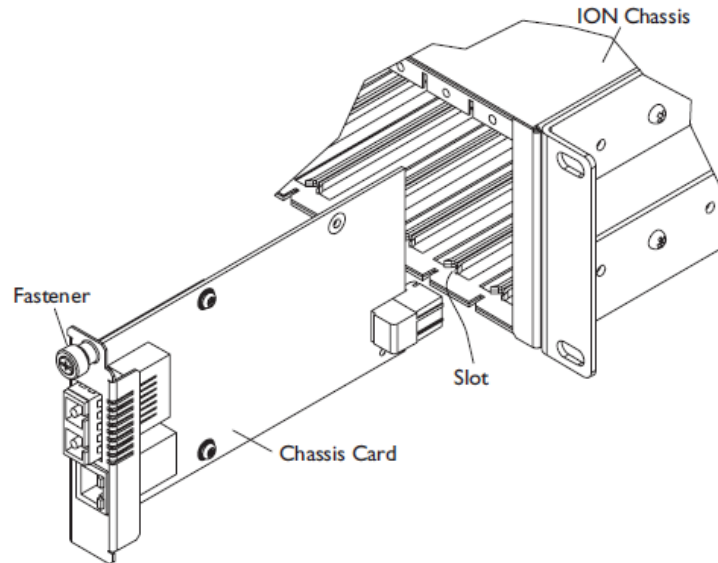

Connect the Fiber Cable

1. Locate a 100Base-FX compliant fiber cable with a male, two-stranded TX to RX connector installed at each end.
2. Connect the fiber cables to the C2110 as described below:
 - Connect the male TX cable connector to the female TX port.
 - Connect the male RX cable connector to the female RX port.
3. Connect the fiber cables to the other device (another C2110, hub, etc.) as described below:
 - Connect the male TX cable connector to the female RX port.
 - Connect the male RX cable connector to the female TX port.

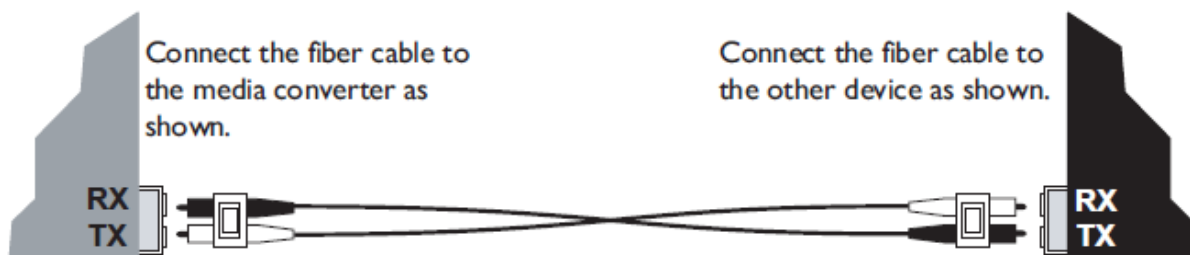

Connect the Twisted-Pair Copper Cable

1. Locate a 100Base-TX compliant cable, with a male RJ-45 connector installed at each end.
2. Connect the RJ-45 connector at one end of the cable to the RJ-45 port on the C2110.
3. Connect the RJ-45 connector at the other end of the cable to the RJ-45 port on the other device (switch, workstation, etc.).

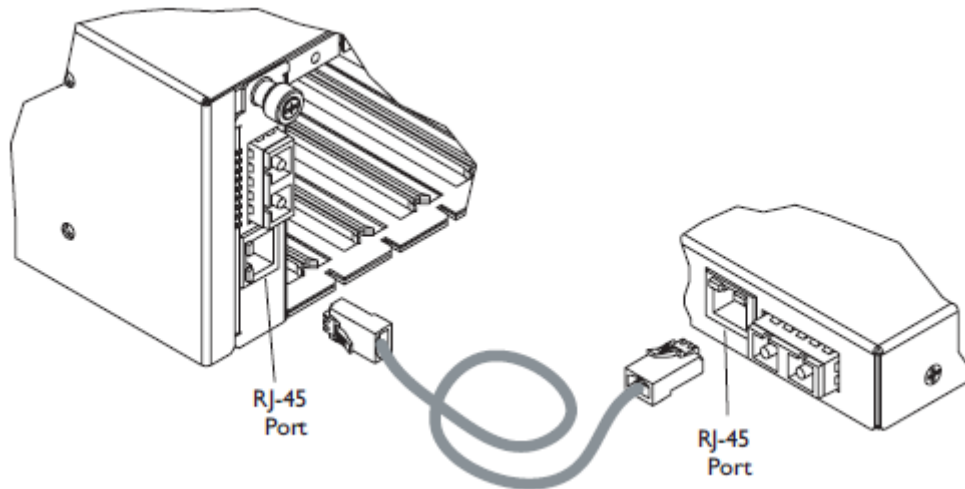

Operation

Status LEDs

The C2110 is designed to operate without user intervention. Use the status LEDs to monitor the C2110 operation in the network.

PWR (Power): ON = Connection to powered ION Chassis backplane.

LKC (Copper Link): ON = Copper Link.

RXC (Receive Copper): Blinking = Data received on Copper link.

LKF (Fiber Link): ON = Fiber Link.

RFX (Receive Fiber): Blinking = Data received on Fiber Link.

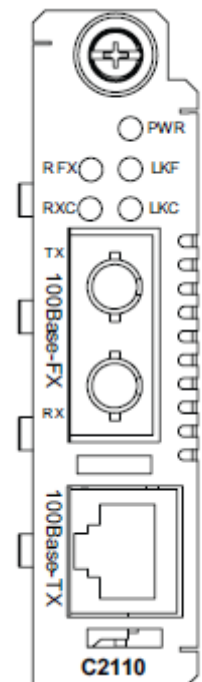

Product Features

Auto-Negotiation

The Auto-Negotiation feature allows the C2110 to automatically configure itself to achieve the best possible mode of operation over a link. The C2110 broadcasts its speed (100 Mb/s) and duplex capabilities (full or half) to the other devices and negotiates the best mode of operation. Auto-Negotiation allows quick and easy installation because the optimal link is established automatically. No user intervention is required.

A scenario where the C2110 is linked to a non-negotiating device, disable Auto-Negotiation. In this instance, the mode of operation will drop to the least common denominator between the two devices (e.g., 100 Mb/s, half-duplex). Disabling this feature enables forcing the connection to the best mode of operation.

Half-duplex Network (512-Bit Rule)

In a half-duplex network, the maximum cable lengths are determined by the round trip delay limitations of each Fast Ethernet collision domain. (A collision domain is the longest path between any two terminal devices, e.g., a terminal, switch, or router.)

The 512-Bit Rule determines the maximum length of cable permitted by calculating the round-trip delay in bit-times (BTU) of a particular collision domain. If the result is less than or equal to 512 BTU, the path is good.

Full-Duplex Network

In a full-duplex network, maximum cable lengths are determined by the type of cables used. See “[Ordering Information](#)” on page 4 for available C2110 models.

The 512-Bit Rule does not apply in a full-duplex network.

Pause Control Frame

The pause control feature can improve network performance by allowing one end of the link to signal the other to discontinue frame transmission for a set period of time to relieve buffer congestion.

Note: If the pause control feature is present on all network devices attached to the C2110(s), enable the pause control feature on the C2110(s). Otherwise, disable this feature.

Link Pass-Through (LPT)

When the Link Pass-Through feature is activated, it allows the C2110 to monitor both the fiber and copper RX (receive) ports for loss of signal. In the event of a loss of an RX signal (1), the C2110 will automatically disable the TX (transmit) signal (2), thus, “passing through” the link loss (3). The far-end device is notified automatically of the link loss (4), which prevents the loss of valuable data transmitted unknowingly over an invalid link.

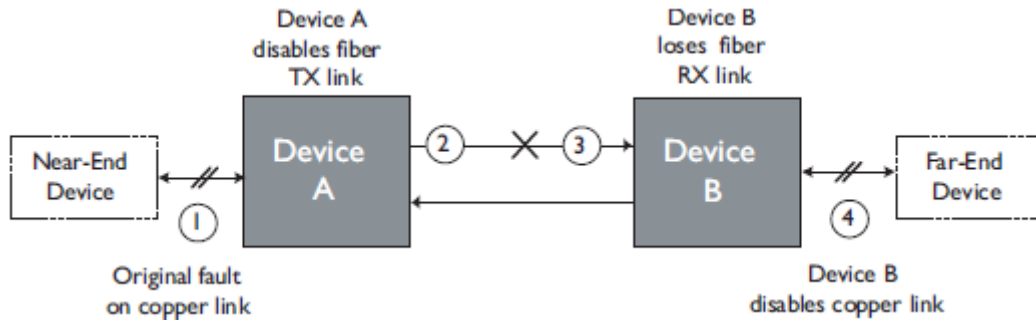

Far-End Fault (FEF)

When a fault occurs on an incoming fiber link (1), the C2110 transmits a Far-End Fault signal on the outgoing fiber link (2). In addition, the Far-End Fault signal also activates the Link Pass-Through, which in turn disables the link on the copper portion of the network (3) and (4).

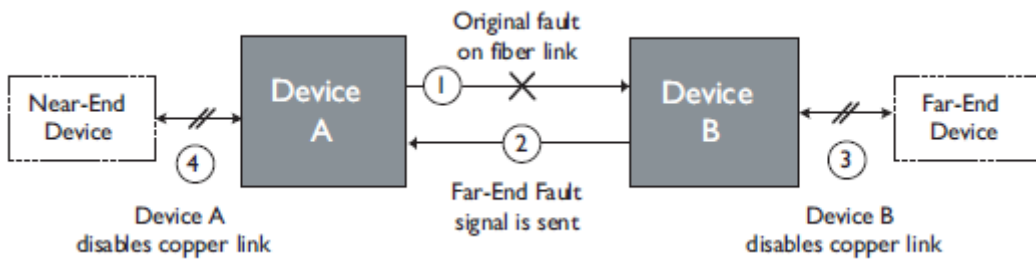

SNMP

See the on-line documentation that comes with Lantronix *FocalPoint™* or *ION* software for applicable commands and usage.

Use SNMP at an attached terminal or at a remote location to monitor the following C2110 activities:

- Media-converter power
- Copper link status and fiber link status
- Twisted-pair cable length
- Hardware switch settings
- Fault condition

Also, use SNMP to enter network commands that:

- Enable/disable Auto-Negotiation
- Enable/disable Link Pass-Through (LPT)
- Enable/disable Far-End Fault (FEF)
- Enable/disable Pause
- Enable/disable AutoCross
- Power down the C2110

Cable Specifications

The physical characteristics must meet or exceed IEEE 802.3™ specifications.

Fiber Cable Specs

The fiber optic transmitters on this device meet Class I Laser safety requirements per IEC-825/CDRH standards and comply with 21 CFR1040.10 and 21CFR1040.11.

Bit Error Rate:	<10 ⁻⁹	
Single mode fiber (<i>recommended</i>):	9 μm	
Multimode fiber (<i>recommended</i>):	62.5/125 μm	
Multimode fiber (<i>optional</i>):	50/125 μm	
C2110-1011	1300 nm multimode	
Fiber Optic Transmitter Power:	min: -19.0 dBm	max: -14.0 dBm
Fiber Optic Receiver Sensitivity:	min: -30.0 dBm	max: -14.0 dBm
Link Budget:	11.0 dB	
C2110-1013	1300 nm multimode	
Fiber Optic Transmitter Power:	min: -19.0 dBm	max: -14.0 dBm
Fiber Optic Receiver Sensitivity:	min: -30.0 dBm	max: -14.0 dBm
Link Budget:	11.0 dB	
C2110-1014	1300 nm single mode	
Fiber-optic Transmitter Power:	min: -15.0 dBm	max: -8.0 dBm
Fiber-optic Receiver Sensitivity:	min: -31.0 dBm	max: -8.0 dBm
Link Budget:	16.0 dB	
C2110-1039	1300nm multimode	
Fiber-optic Transmitter Power:	min: -19 dBm	max: -14.0 dBm
Fiber-optic Receiver Sensitivity:	min: -30 dBm	max: -14.0 dBm
Link Budget:	11 dB	
C2110-1029-A1	1310nm TX/1550nm RX single mode	
C2110-1029-A2	1550nm TX/1310nm RX single mode	
Fiber Optic Transmitter Power:	min: -14.0 dBm	max: -8.0 dBm
Fiber Optic Receiver Sensitivity:	min: -33.0 dBm	max: -3.0 dBm
Link Budget:	19.0 dB	

Copper Cable Specs

Category 5: (minimum requirement)

Gauge: 24 to 22 AWG
Attenuation: 22.0 dB /100m @ 100 MHz
Maximum Cable Distance: 100 meters

- Straight-through or crossover twisted-pair cable may be used.
- Shielded twisted-pair or unshielded twisted-pair may be used.
- Pins 1&2 and 3&6 are the two active pairs in an Ethernet network.
- Use only dedicated wire pairs for the active pins (*e.g., blue/white & white/blue, orange/white & white/orange, etc.*)
- Do not use flat or silver satin wire.

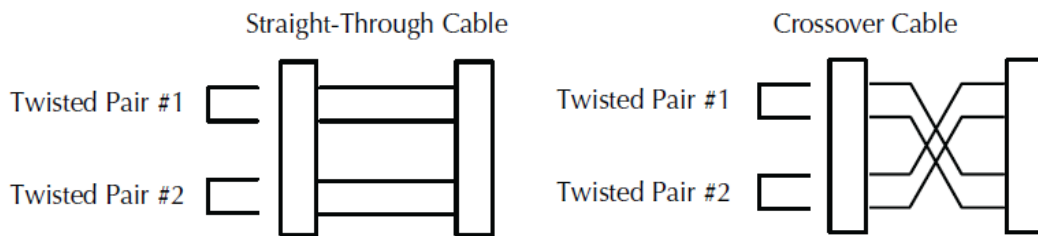

Technical Specifications

For use with Lantronix Model C2110 or equivalent.

Standards:	IEEE Std. 802.3
Data Rate:	100 Mbps, Layer-1
Max packet size	9K bytes
Dimensions:	Width: 0.86" [22 mm] x Depth: 6.5" [165 mm] x Height: 3.4" [86 mm]
Shipping Weight:	1 lb (0.45 kg) approximately
Power Consumption:	2.5W-3.5W depending on the optic installed
MTBF:	greater than 250,000 MIL-HDBK-217F hours greater than 667,500 Bellcore hours
Environment:	See chassis specifications
Storage Temp:	-25 to 65°C (-13 to 149°F)
Humidity:	5 to 95%, non-condensing
Warranty:	Lifetime
Regulatory Compliance:	CISPR/EN55022 Class A, FCC Class A, CE Mark, NDAA Compliant, TAA Compliant

The information in this user's guide is subject to change.

This product is certified by the manufacturer to comply with DHHS Rule 21/CFR, Subchapter J applicable at the date of manufacture.

CAUTION: Visible and invisible laser radiation when open. Do not stare into the beam or view directly with optical instruments.

CAUTION: Use of controls, adjustments or the performance of procedures other than those specified herein may result in hazardous radiation exposure.

CAUTION: Copper based media ports, e.g., Twisted Pair (TP) Ethernet, USB, RS232, RS422, RS485, DS1, DS3, Video Coax, etc., are intended to be connected to intrabuilding (*inside plant*) link segments that are not subject to lightening transients or power faults. Copper based media ports, e.g., Twisted Pair (TP) Ethernet, USB, RS232, RS422, RS485, DS1, DS3, Video Coax, etc., are NOT to be connected to interbuilding (*outside plant*) link segments that are subject to lightening transients or power faults. Failure to observe this caution could result in damage to equipment.

PCB Revision Examples

PCB 11348 Rev. 01

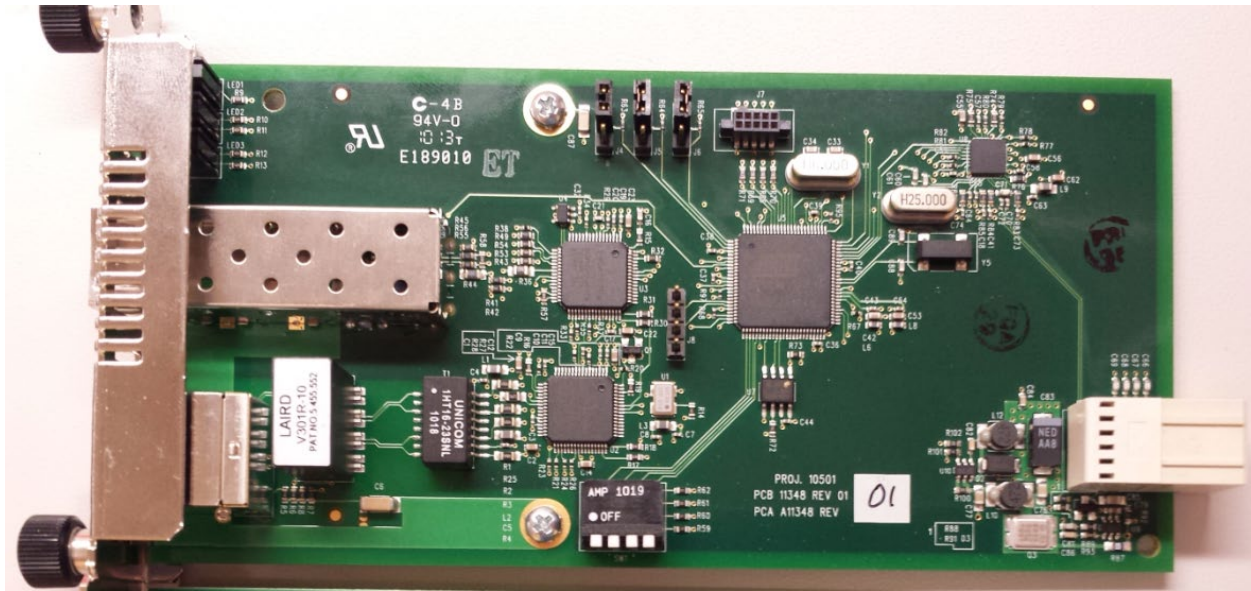

PCB 11348 Rev. A

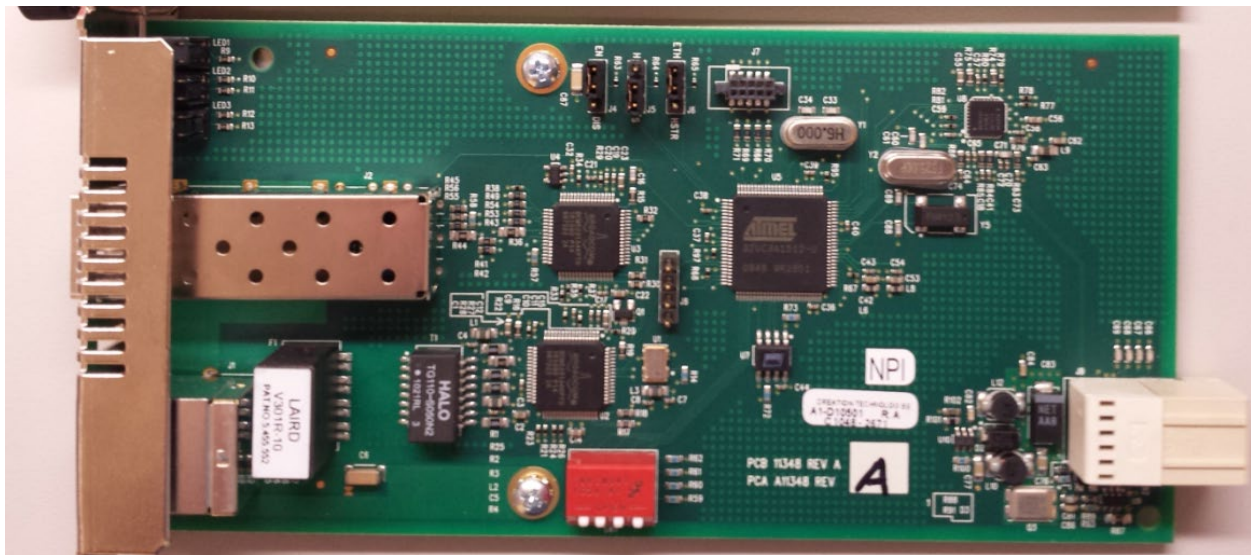

PCB 11322 Rev. 02



PCB 11322 Rev. A

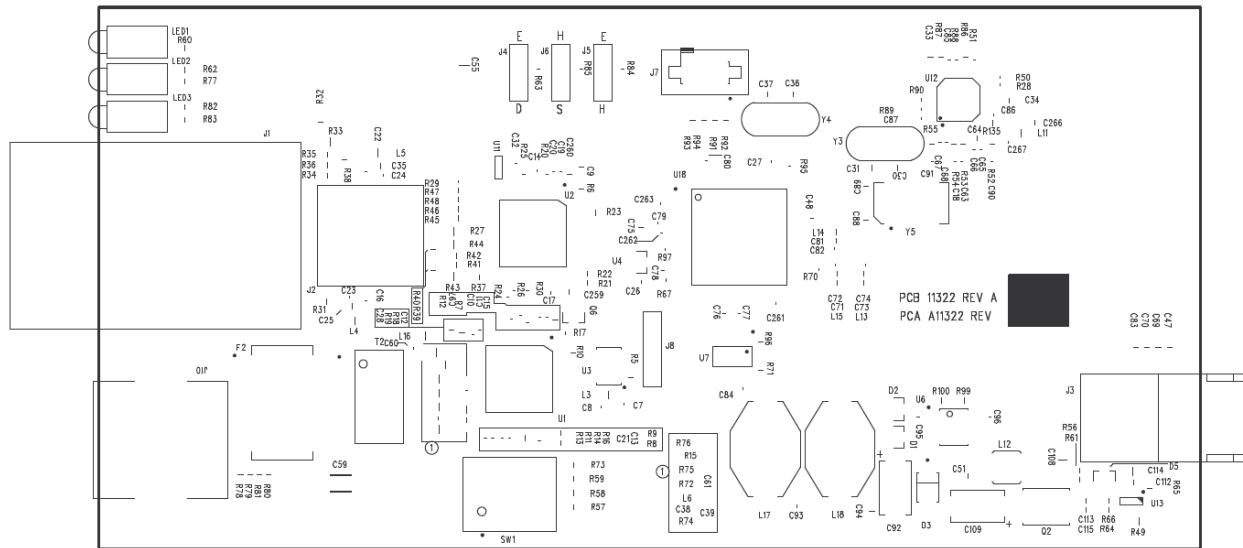

TRANSITION NETWORKS, INC.
11322 REV A

Troubleshooting

If the C2110 fails, isolate and correct the failure by determining the answers to the following questions and then taking the indicated action:

1. Is the **PWR** LED on the C2110 lit?
NO
 - Is the C2110 installed properly in the chassis?
 - Is the power cord properly installed in the chassis and at the external power source?
 - Is the external power source active?
 - Contact Technical Support.YES
 - Proceed to step 2.
2. Is the **LKC** LED on the C2110 lit?
NO
 - Check the twisted-pair cables for proper connection.
 - Contact Technical Support.YES
 - Proceed to step 3.
3. Is the **LKF** LED on the C2110 lit?
NO
 - Check the fiber cables for proper connection.
 - Verify that the TX and RX cables on the C2110 are connected to the RX and TX ports, respectively, on the other device.
 - Contact Technical Support.YES
 - Proceed to step 4.
4. Is the **RXC** LED on the C2110 flashing?
NO
 - If there is no activity on the 100Base-TX port, proceed to step 5.
 - If there is activity on the 100Base-TX port, disconnect and reconnect the 100Base-TX cable to restart the initialization process.
 - Restart the workstation to restart the initialization process.
 - Contact Technical Support.YES
 - Proceed to step 5.
5. Is the **RXF** LED on the C2110 flashing?
NO
 - If there is activity on the 100Base-FX port, disconnect and reconnect the 100Base-FX cable to restart the initialization process.
 - Verify that the TX and RX cables on the C2110 are connected to the RX and TX ports, respectively, on the other device.
 - Restart the workstation to restart the initialization process.
 - Contact Technical Support.YES
 - Contact Technical Support.

Compliance Information

FCC Regulations

This equipment has been tested and found to comply with the limits for a Class A digital device, pursuant to part 15 of the FCC rules. These limits are designed to provide reasonable protection against harmful interference when the equipment is operated in a commercial environment. This equipment generates, uses, and can radiate radio frequency energy and, if not installed and used in accordance with the instruction manual, may cause harmful interference to radio communications.

Operation of this equipment in a residential area is likely to cause harmful interference, in which case the user will be required to correct the interference at the user's own expense.

Canadian Regulations

This digital apparatus does not exceed the Class A limits for radio noise for digital apparatus set out on the radio interference regulations of the Canadian Department of Communications.

Le présent appareil numérique n'émet pas de bruits radioélectriques dépassant les limites applicables aux appareils numériques de la Class A prescrites dans le Règlement sur le brouillage radioélectrique édicté par le ministère des Communications du Canada.



CAUTION: RJ connectors are NOT INTENDED FOR CONNECTION TO THE PUBLIC TELEPHONE NETWORK. Failure to observe this caution could result in damage to the public telephone network.

Der Anschluss dieses Gerätes an ein öffentliches Telekommunikationsnetz in den EGMitgliedstaaten verstösst gegen die jeweiligen einzelstaatlichen Gesetze zur Anwendung der Richtlinie 91/263/EWG zur Angleichung der Rechtsvorschriften der Mitgliedstaaten über Telekommunikationsendeinrichtungen einschliesslich der gegenseitigen Anerkennung ihrer Konformität.



In accordance with European Union Directive 2002/96/EC of the European Parliament and of the Council of 27 January 2003, Lantronix will accept post usage returns of this product for proper disposal. The contact information for this activity can be found in the 'Contact Us' portion of this document.

Declaration of Conformity

Manufacture's Name: Lantronix, Inc.

Manufacture's Address: 48 Discovery, Suite 250, Irvine, California 92618 USA

Declares that the product(s):

C2110-1011, C2110-1013, C2110-1014, C2110-1015, C2110-1016, C2110-1017, C2110-1019,
C2110-1035, C2110-1029-A1, C2110-1029-A2, C2110-1039, C2110-1040, C2110-1029-B1, C2110-
1029-B2, C2110-1029-C1, C2110-1029-C2, C2110-1029-D1, C2110-1029-D2

Conforms to the following Product Regulations:

EMC Directive 2004/108/EC; EN 55022:2006+A1:2007 Class A; EN55024:1998+A1 2001+A2:2003;
EN61000-3-2; EN61000-3-3; CFR Title 47 Part 15 Subpart B Class A; Low Voltage Directive:
2006/95/EC; CFR Title 21 Section 1040.10 Class 1.

With the technical construction on file at the above address, this product carries the CE Mark

I, the undersigned, hereby declare that the equipment specified above conforms to the above Directive(s) and Standard(s).

Place: Irvine, California

Date: April 27, 2023

Signature: *Eric Bass*

Full Name: Eric Bass

Position: Vice President of Engineering

**Lantronix Corporate Headquarters**

48 Discovery, Suite 250
Irvine, CA 92618, USA
Toll Free: 800-526-8766
Phone: 949-453-3990
Fax: 949-453-3995

Technical Support

Online: <https://www.lantronix.com/technical-support/>

Sales Offices

For a current list of our domestic and international sales offices, go to the Lantronix web site at www.lantronix.com/about/contact